





# SERVICE MANUAL



[ IMPORTANT ]

- ▶ Please read the manual carefully and keep it in mind before using this machine
- ▶ Put this manual within touch of your reference in anytime.

ISSUE DATE:Jan. 23, 2024

PRODUCT INFO	PART INFO	SUPPORT INFO	NEW PRODUCT INFO
			

※ QR(SUPPROT) - Leaflets, manuals, solution(error code,trouble shooting document, watch&solve)

# PRECAUTIONS FOR USE

The following safety precautions are given throughout this manual. They must be strictly followed to protect those who install, use or maintain this product as well as to protect players, visitors and property.

For safety reasons.

- The following suggestions should be adhered to:



## WARNING

Disregarding could result in serious injury.



## CAUTION

Disregarding could result in injury or product damage.

- The following graphic suggestions describe the types of precautions to be followed.



Indicates a care should be taken.



Forbidden.



Indicates a matter which must be performed.

- Precautions to be followed:

**Certain procedures require a qualified in-shop maintenance person or industry specialist. For such instructions, a qualified person must take care of the jobs.**

- Otherwise an electric shock, machine trouble, or a serious accident may result.
- Replacing the machine parts, inspecting and maintaining the machines, and troubleshooting must be assigned only to a qualified in-shop maintenance person or industry specialist. This booklet gives instructions that hazardous jobs in particular must be handled by an industry specialist. Qualified in-shop maintenance person and industry specialist are defined as follows.

### **Qualified in-shop maintenance person**

- A service staff shall have experience in operations of game machines. The staff shall be responsible for assembly, installation, inspection and maintenance of the machine.

### **Industry specialist**

- An industry specialist must be engaged in designing, manufacturing, inspecting and servicing amusement machines. He or she must have an education in electrical, electronic and mechanical engineering, and routinely maintain and repair amusement machines.

# PRECAUTIONS FOR USE

## WARNING

If there is any abnormality such as smoke, bad smell or abnormal noise being emitted from the machine, immediately turn OFF the main power switch and unplug the power cord from the receptacle to stop operating it. 

- Using the machine in abnormal conditions could result in fire or accidents.

In case of abnormality

1. Turn OFF the main power switch.
2. Unplug the power cord from the receptacle.
3. Contact your nearest dealer.

**Do not leave the power cord plugged in improperly or covered with dust.** 

- Doing so could result the power cord periodically.

## CAUTION

**Do not use this product anywhere other than industrial areas.** 

- Using in a residential area or an area next to a residential area could affect signal reception of radios, television sets, telephones, etc..
- Do not give shock the surface of glass products.

- Please do not play this game if
  - When you do drinking;
  - When your physical condition is not normal;
  - When you are in pregnancy;
  - When you have on a pulse controller;
  - When you have recently experienced a cramp or fainting away while watching TV.
- Avoid excessive force/shock while playing/moving the game.
- While do games, pay attention to surrounding.

**Do not plug or unplug the power cord with wet hands.** 

**In handling the power cord, follow the instructions below.** 

- |   |  |
|---|--|
| • Do not damage the power cord.           | • Do not modify the power cord.            |
| • Do not bend the power cord excessively. | • Do not twist the power cord.             |
| • Do not heat the power cord.             | • Do not pull the power cord.              |
| • Do not bind the power cord.             | • Do not stand on the power cord.          |
| • Do not sandwich the power cord.         | • Do not drive a nail into the power cord. |

**If the power cord or power plug becomes damaged, stop using the machine immediately and ask your nearest dealer to replace the parts.**

# PRECAUTIONS FOR USE

## WARNING

**Be sure to consult an industry specialist when setting up, moving or transporting this product.**

- This product should not be set up, moved or transported by any one other than an industry specialist.
- When installing this product, set the 4 leg levelers evenly on the floor and make sure that the product is installed stably in a horizontal position. Unstable installation may result in injury or accident.
- When installing this product, do not apply undue force on movable parts. Otherwise, injury and accident may result, or the product may be damaged.

**The machine for indoor usage only does not install outside.**



**Do not set the game machine up near emergency exits.**



**Protect the game machine from:**

- Rain or moisture.
- Direct sunlight.
- Direct heat from air-conditioning and heating equipment, etc..
- Hazardous flammable substances.
- Otherwise an accident or malfunction may result.



**Do not place containers holding chemicals or water on or near the game machine.**



**Do not place objects near the ventilating holes.**



**Do not bend the power cord by force or place heavy objects on it.**



**Never plug or unplug the power cord with wet hands.**



**Never unplug the game machine by pulling the power cord.**



## CAUTION

**Be sure to use indoor wiring within the specified voltage requirements. For extension cord, use the specified rating or more.**

**Be sure to use the attached power cord.**

**Never plug more than one cord at a time into the electrical receptacle.**



**Do not lay the power cord where people walk through.**



**Be sure to ground this product.**



**Do not exert excessive force when moving the machine.**





**For proper ventilation, keep the game machine 100mm(4") away from the walls.**

**Do not alter the system related dipswitch settings.**

# PRECAUTIONS FOR USE

## WARNING

Be sure to turn OFF the main power switch and unplug the power cord from the receptacle before inspecting or cleaning the machine. 

When replacing parts, be sure to use parts of the correct specifications. Never use parts other than the specified ones. 

Opening inside the machine shall be done by machine specialist only as high electric current is being sent inside. For game machine with monitor, a care should be taken while opening its back door. If not, a damage to the inside parts or the monitor may occur. 

If the sub power switch of the service panel is turned OFF without turning OFF the main power switch of the power supply unit, some parts in the units remain live. When opening the back door, be sure to turn OFF the main power switch and unplug the power cord from the receptacle. 

Strictly refrain from disassembly and repair of parts which are not indicated in this manual, as well as settings and remodeling. 

To clean the game machine, wipe it with a soft cloth dampened in a neutral detergent.

- Using thinner or other organic solvent or alcohol may decompose the material.
- Electrical shock or equipment failure could be caused by water entering the inside of the machine.

## CAUTION

Components in the game are sensitive to vibrations and impact. Care should be used when moving and transporting the game machine. 

Be sure not to let the machine tip over.

Before moving the machine, be sure to turn OFF the main power switch, unplug the power cord from the receptacle and remove the power cord from the machine. 

Before moving take the machine, off the levelers and move it on the casters.

Avoid excessive force while moving the machine.

.....

## PRECAUTIONS IN HANDLING

- When setting up, inspecting, maintaining, moving or transporting this product, follow the procedures and instructions set forth in this manual and perform such work safely.
- Do not set up, handle, inspect, maintain, move or transport this product under conditions equivalent to the condition of "WARNING" or "CAUTION" specified in this manual.
- If a new owner is to have this product as a result of transfer, etc., be sure to give this manual to the new owner.

# PRÉCAUTION D'EMPLOI

Les consignes de sécurité suivantes sont données dans ce manuel. Elles doivent être strictement suivies pour protéger ceux qui les installent. Utiliser ou entretenir ce produit pour la sécurité des utilisateurs, des visiteurs et des biens.

Pour des raisons de sécurité.

- **Les suggestions suivantes doivent être respectées:**

## **ATTENTION**

Le non-respect peut entraîner des blessures graves.

## **PRUDENCE**

Le non-respect peut entraîner des blessures ou des dommages au produit.

- **Les suggestions graphiques suivantes décrivent les types de précautions à prendre.**



Indique qu'attention est requise.



Interdit.



Indique que quelque chose doit être effectuée.

- **Les précautions à prendre :**

**Certaines procédures exigent une personne de maintenance qualifiée en atelier ou un spécialiste de l'industrie. Pour ces instructions, une personne qualifiée doit prendre soin des travaux.**

- Sinon, un choc électrique, un dysfonctionnement de la machine, ou un accident grave peut en résulter.
- Remplacement des pièces de machines, l'inspection et la maintenance des machines, et le dépannage doit être attribué qu'à une personne de maintenance qualifiée en atelier ou spécialiste de l'industrie. Cette brochure donne des instructions que les emplois dangereux, en particulier, doivent être traités par un spécialiste de l'industrie. La personne de maintenance qualifiée en atelier et le spécialiste de l'industrie sont définis comme suit.

### **La personne de maintenance qualifiée en atelier**

- Un personnel de service doit avoir de l'expérience dans les opérations de machines de jeux. Le personnel est responsable pour l'assemblage, l'installation, l'inspection et l'entretien de la machine.

### **Le spécialiste de l'industrie**

- Un spécialiste de l'industrie doit être engagé dans la conception, la fabrication, l'inspection et l'entretien des appareils d'amusement.  
Il ou elle doit avoir une formation en génie électrique, électronique et mécanique, et de maintenir régulièrement et de réparer les appareils d'amusement.

# PRÉCAUTION D'EMPLOI

## ATTENTION

Si il y a une anomalie comme fumée, mauvaise odeur ou bruit anormal émis par la machine,  couper immédiatement l'interrupteur principal et débranchez le câble d'alimentation de la prise pour arrêter son fonctionnement.

- L'utilisation de l'appareil dans des conditions anormales peut provoquer un incendie ou un accident.

En cas d'anomalie

1. Mettez l'interrupteur principal sur ARRÊT.
2. Débranchez le câble d'alimentation de la prise.
3. Contactez votre revendeur le plus proche.

**Ne pas brancher le câble d'alimentation incorrectement ou le laisser être recouvert de poussière.** 

Cela pourrait nuire le câble d'alimentation.

## PRUDENCE

**Ne pas utiliser ce produit ailleurs que dans les zones industrielles.** 

- L'utiliser dans une zone résidentielle ou d'une zone à côté d'un quartier résidentiel pourrait nuire à la réception des radios, téléviseurs, téléphones, etc.
- Ne donnez pas de choc à la surface d'un produit en verre.

- S'il vous plaît ne pas jouer à ce jeu.
  - Quand vous buvez;
  - Lorsque votre condition physique n'est pas normale;
  - Lorsque vous êtes dans une période de grossesse;
  - Lorsque vous avez un contrôleur d'impulsion;
  - Lorsque vous avez récemment subi une crampe ou évanouissement en regardant la télévision.
- Évitez une force excessive / un choc pendant la lecture / de déplacer le jeu.
- Quand vous jouez les jeux, faite attention aux alentours.

**Ne pas brancher ou débrancher le câble d'alimentation avec les mains mouillées.** 

**Dans la manipulation du câble d'alimentation, suivez les instructions ci-dessous.** 

- |  |   |
|--|---|
| • Ne pas endommager le câble d'alimentation.                 | • Ne pas modifier le câble d'alimentation.            |
| • Ne pas plier le câble d'alimentation de manière excessive. | • Ne tordez pas le câble d'alimentation.              |
| • Ne pas chauffer le câble d'alimentation.                   | • Ne tirez pas sur le câble d'alimentation.           |
| • Ne pas lier le câble d'alimentation.                       | • Ne montez pas sur le câble d'alimentation.          |
| • Ne pas prendre en sandwich le câble d'alimentation.        | • Ne pas mettre un clou dans le câble d'alimentation. |

**Si la fiche du câble d'alimentation ou est endommagé, cessez immédiatement d'utiliser la machine et demandez à votre revendeur le plus proche de remplacer les pièces.**

# PRÉCAUTION D'EMPLOI

## ⚠ ATTENTION

**Assurez-vous de consulter un spécialiste de l'industrie lors de la mise en place, du déplacement ou le transport de ce produit.**

- Ce produit ne doit pas être mis en place, déplacé ou transporté par une quelconque autre qu'un spécialiste de l'industrie.
- Lors de l'installation de ce produit, installez 4 niveleurs de pieds uniformément sur le sol et assurez-vous que le produit est installé de façon stable dans une position horizontale. Une installation instable peut entraîner des blessures ou un accident.
- Lors de l'installation de ce produit, ne pas appliquer une force excessive sur les pièces mobiles. Sinon, des blessures et des accidents peuvent y résulter, ou le produit peut être endommagé.

**La machine pour une utilisation en intérieur uniquement, ne pas installer à l'extérieur.**



**N'installez pas la machine de jeu près des issues de secours.**



**Protéger la machine de jeu de:**



- L'humidité ou la pluie.
- La lumière directe du soleil.
- La chaleur directe de la climatisation et du chauffage, etc...
- Des substances inflammables dangereuses.
- Sinon, un accident ou un dysfonctionnement.

**Ne pas placer les récipients contenant des produits chimiques ou de l'eau sur ou près de la machine de jeu.**



**Ne placez pas d'objets à proximité des orifices de ventilation.**



**Ne pas plier le cordon d'alimentation par la force ou de placer des objets lourds au-dessus.**



**Ne jamais brancher ou débrancher le cordon d'alimentation avec les mains mouillées.**



**Ne jamais débrancher la machine de jeu en tirant le câble d'alimentation.**



## ⚠ PRUDENCE

**Veillez à utiliser le câblage intérieur selon les exigences de tension spécifiées. Pour une rallonge, utilisez la notation spécifiée ou plus.**

**Veillez à utiliser le cordon d'alimentation fourni.**

**Ne jamais brancher plus d'un cordon à la fois dans la prise électrique.**



**Ne pas poser le cordon d'alimentation où les gens marchent à travers.**



**Soyez sûr de mettre à la terre ce produit.**



**Ne pas exercer une force excessive lors du déplacement de la machine.**



**Pour une ventilation correcte, garder la machine de jeu 100mm (4 ") loin des murs.**

**Ne pas modifier les réglages des commutateurs DIP liées au système.**





# PRÉCAUTION D'EMPLOI

## ⚠ ATTENTION

Veillez à éteindre l'interrupteur d'alimentation principale et débranchez le cordon d'alimentation de la prise avant d'inspecter ou de nettoyer la machine. 

Lors du remplacement des pièces, veillez à utiliser une partie des spécifications correctes. Ne jamais utiliser de pièces autres que celles spécifiées. 

L'ouverture à l'intérieur de la machine doit être effectuée par le spécialiste de la machine seulement, comme le courant électrique élevé est transmis à l'intérieur. Pour la machine de jeu avec le moniteur, un soin doit être pris lors de l'ouverture de sa porte arrière. Si non, une détérioration des pièces à l'intérieur ou à l'écran peut se produire. 

Si l'interrupteur secondaire du panneau de service est éteint sans éteindre le commutateur d'alimentation principale de l'unité d'alimentation, certaines parties dans les unités restent sous tension. Lors de l'ouverture de la porte arrière, veillez à éteindre l'interrupteur d'alimentation principale et débranchez le cordon d'alimentation de la prise. 

Il est strictement conseillé de s'abstenir de démonter et de réparer des pièces qui ne sont pas indiqués dans ce manuel, ainsi que les paramètres et le remodelage. 

Pour nettoyer la machine de jeu, l'essuyer avec un chiffon doux imbibé avec un détergent neutre.

- L'utilisation plus mince d'un autre solvant organique ou de l'alcool peut décomposer le matériel.
- Un choc électrique ou une défaillance de l'équipement pourraient être causés par la pénétration de l'eau à l'intérieur de la machine.

## ⚠ PRUDENCE

Les composants de la machine de jeu sont sensibles aux vibrations et aux chocs. Il faut faire attention lors du déplacement et le transport de la machine de jeu. 

Veillez à ne pas laisser la machine se renverser.

Avant de déplacer la machine, veillez à éteindre l'interrupteur d'alimentation principale, débranchez le cordon d'alimentation de la prise et débranchez le cordon d'alimentation de la machine. 

Avant de déplacer la machine, la mettre hors des niveleurs et le déplacer sur les roulettes.

Éviter une force excessive lors du déplacement de la machine.

.....

## PRÉCAUTIONS LORS DU MANIEMENT

- Lors de la mise en place, l'inspection, l'entretien, déplacement ou le transport de ce produit, suivez les procédures et les instructions énoncées dans ce manuel et effectuer ce travail en toute sécurité.
- Ne pas mettre en place, manipuler, inspecter, entretenir, déplacer ou transporter ce produit dans des conditions équivalentes à l'état de "ATTENTION" ou "PRUDENCE" spécifiée dans ce manuel.
- Si un nouveau propriétaire obtient ce produit à la suite d'un transfert, etc., soyez sûr de donner ce manuel au nouveau propriétaire.

# CONTENTS

1. SPECIFICATION AND DIMENSION .....	P02	5. TROUBLESHOOTING .....	P26
1-1. DIMENSION .....	P02	5-1. IN CASE OF POWER FAILURE .....	P26
1-2. SPECIFICATION .....	P02	5-2. MOTOR ERROR .....	P26
1-3. NAME OF PARTS .....	P03	5-3. MICRO SWITCH ERROR .....	P27
1-4. STICKER LOCATION .....	P04	5-4. COIN SELECTOR ERROR .....	P28
1-5. COMPONENTS .....	P04	5-5. SOUND ERROR .....	P29
2. INSTALLATION .....	P05	5-6. BUTTON & COUNTER ERROR .....	P30
2-1. INSTALLATION SPACE .....	P05	5-7. SETUP LCD PCB ERROR .....	P31
2-2. PRECUTIONS FOR .....	P05	5-8. UPPER SIDE LIGHT PCB & CREDIT FND, TIME FND ERROR .....	P32
2-3. READER AND .....	P05	6. EXPLODED VIEW .....	P33
CARD READER REPLATED BILLS		6-1. MAIN CABINET PART .....	P33
2-4. HOW TO INSTALL BILLBOARD .....	P06	6-2. BILLBOARD PART .....	P34
2-5. HOW TO INSTALL .....	P07	6-3. TAEGET DISPLAY PART .....	P35
3. SETUP SETTING .....	P08	6-4. PRIZE GUIDE PART .....	P36
3-1. MACHINE SETUP .....	P08	6-5. PRIZE DISPENSER PART_TOP .....	P37
3-2. STATUS MODE .....	P09	6-6. PRIZE DISPENSER PART_MIDDLE .....	P37
3-3. SETUP MODE .....	P12	6-7. PRIZE DISPENSER PART_BOTTOM .....	P38
3-4. TEST MODE .....	P16	6-8. PRIZE DISPENSER PART .....	P38
3-5. ERROR CODE .....	P22	6-9. BUTTOM FRAME PART .....	P39
4. HOW TO REPLACE MAJOR .....	P24	6-10. SMPS PANEL PART .....	P39
COMPONENTS		6-11. AC INPUT PART .....	P40
4-1. REPLACING MAIN PCB .....	P24	7. WARRANTY ITEM .....	P41
4-2. REPLACING COIN SELECTOR .....	P24	8. BLOCK DIAGRAM .....	P43
4-3. REPLACING PRIZE DISPENSER PART & Z MOVING PART .....	P25		

# 1. SPECIFICATION AND DIMENSION

## 1-1. DIMENSION

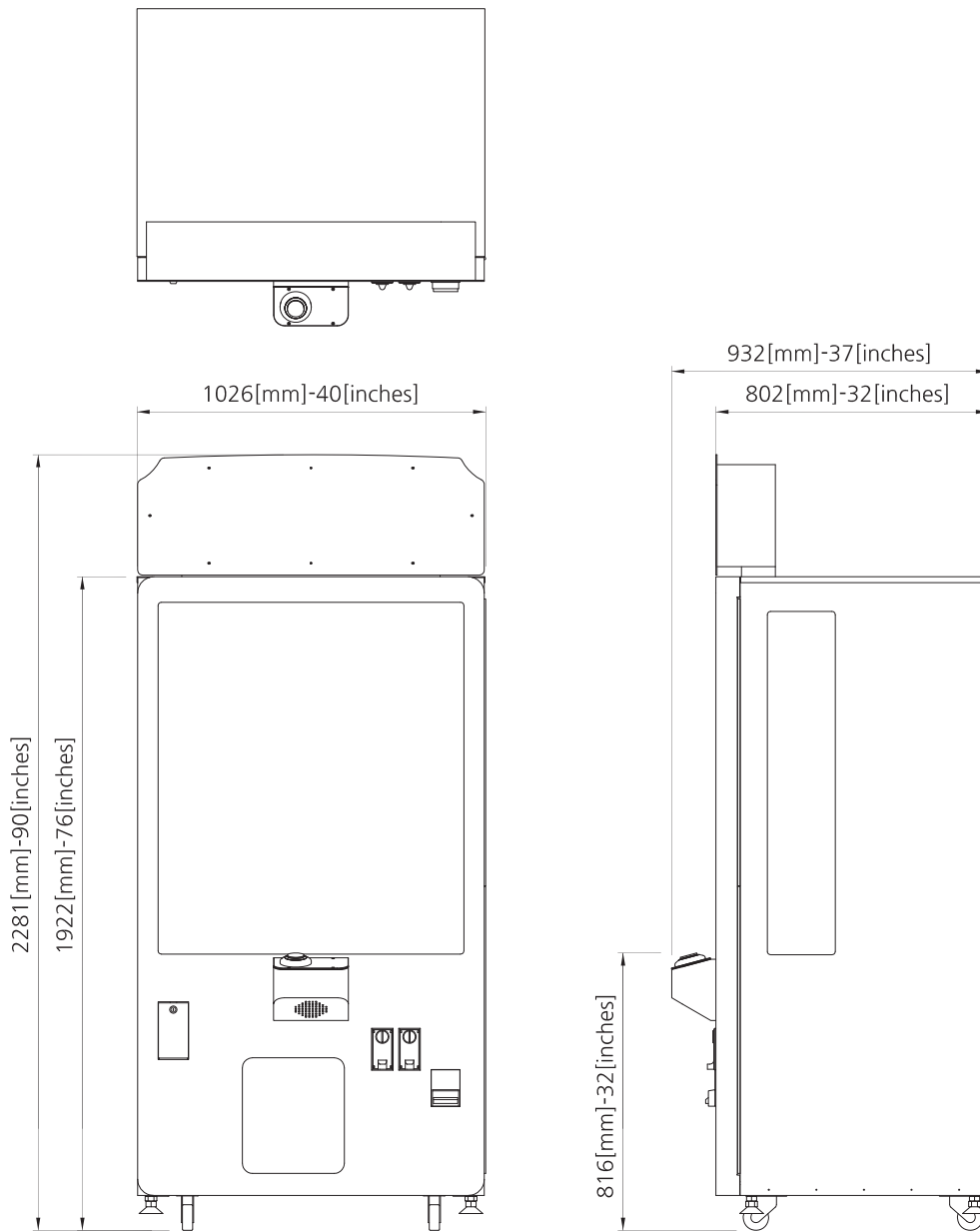

## 1-2. SPECIFICATION

DIMENSION (W x D x H)	1026 x 932 x 2254 (mm)
PACKING DIMENSION (W x D x H)	1150 x 850 x 2281 (mm)
WEIGHT (kg)	280 kg [ WEIGHT INCLUDING PACKAGING : 310 kg ]
VOLTAGE	AC 120V
FREQUENCY RANGE	60Hz
CONSUMPTION	280 W

### 1-3. NAME OF PARTS

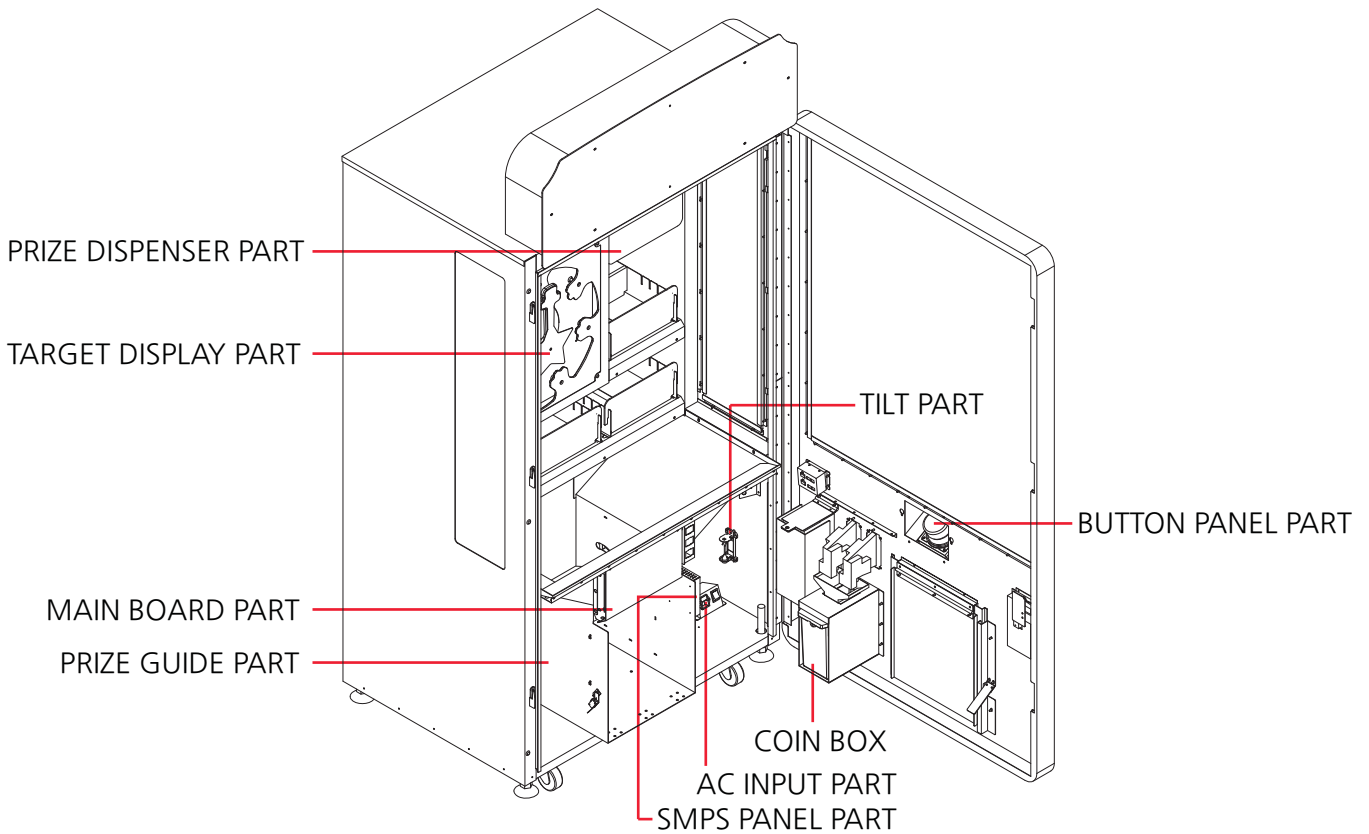
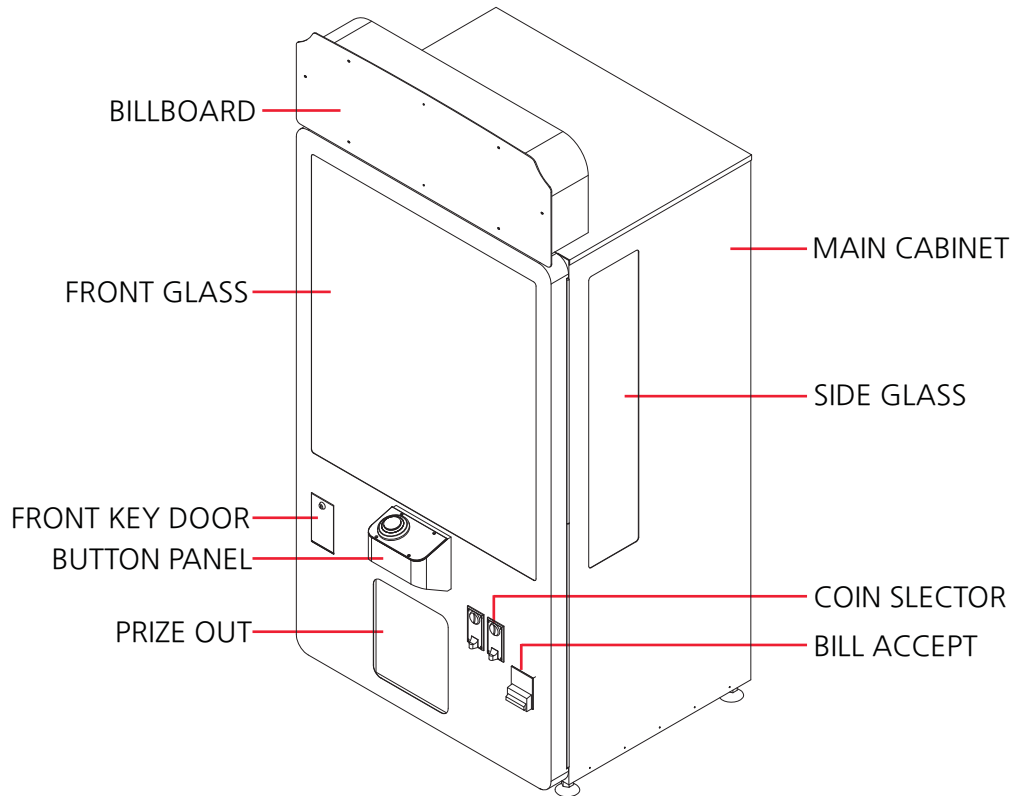

# 1-4. STICKER LOCATION

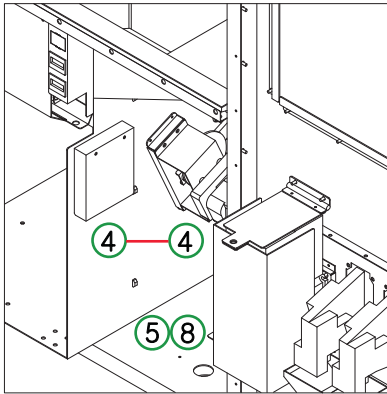
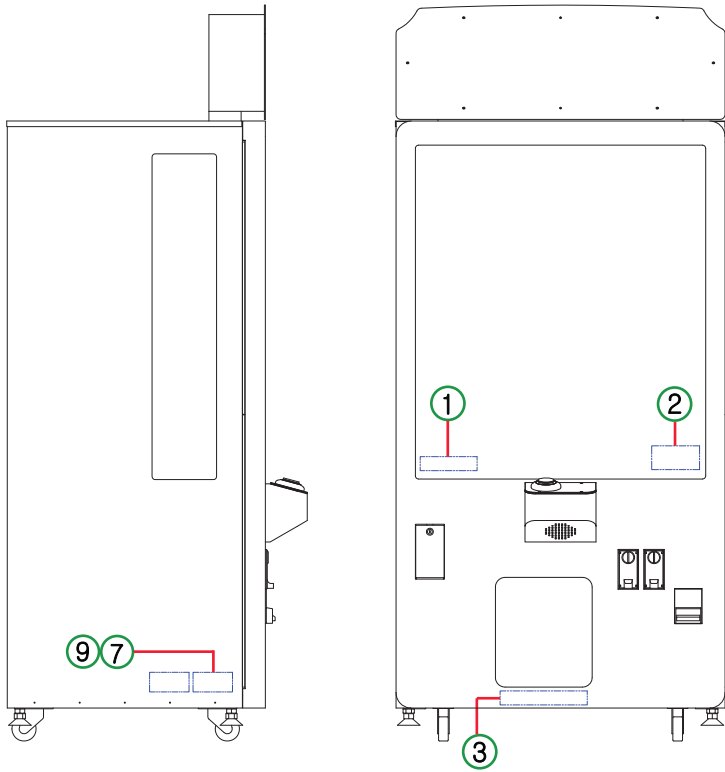

\* CASE inner bottom

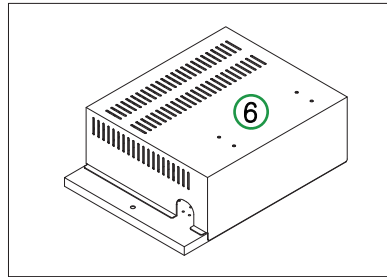

\* SMPS PANEL

1

2

3

4

5

6

7

8

9

# 1-5. COMPONENTS

NO.	PART NAME	SPEC.	QTY
1	AC POWER CORD	120V	1
2	KEY	6001	2
3	KEY	7001	2
4	BOLT	M6x16L	11
5	BOLT	M4x10L	16
6	WRENCH	2.5mm	1
7	MANUAL	-	1

## 2. INSTALLATION

### 2-1. INSATALLATION

- Need to have installation place.  
Maintenance Zone & Play zone should have at least 2000mm x 2500mm each.

#### IMPORTANT

- Once you set up the machine with required game-play area, when installing this product, set the 4 leg levelers evenly on the floor and make sure that the product is installed stably in a horizontal position. Otherwise the set winning percentage can be twisted.

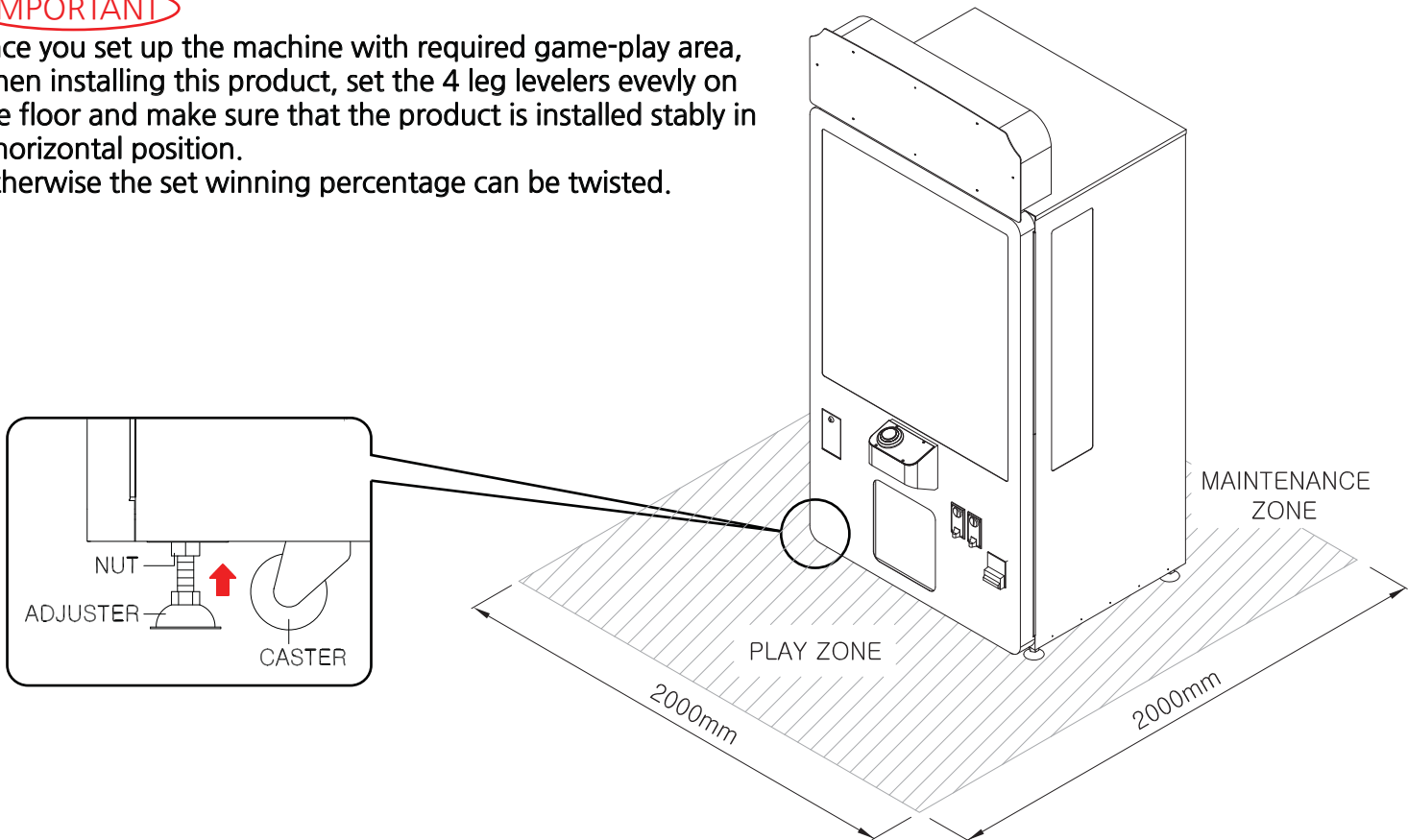

### 2-2. PRECAUTIONS FOR

- \* Optimum temperature for game operation is between  $-10^{\circ}\text{C}$  to  $45^{\circ}\text{C}$ . Installing/operating the game outside given temperature range may cause malfunction or damages to the components.

### 2-3. READER AND CARD READER RELATED BILLS

- This machine can install Credit Card Reader or Bill Acceptor as an Option.

## 2-4. HOW TO INSATLL BILLBOARD



- Separate ① the BILLBOARD FRAME SUPT-B inside the BILLBOARD FRAME. [M6, 2EA]

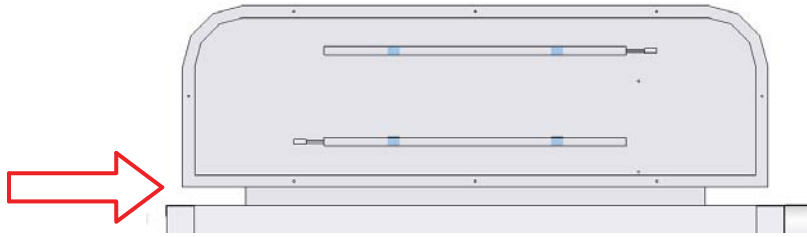

- After disassembly, assemble it so that it is in the bottom position. [Bolt reuse]

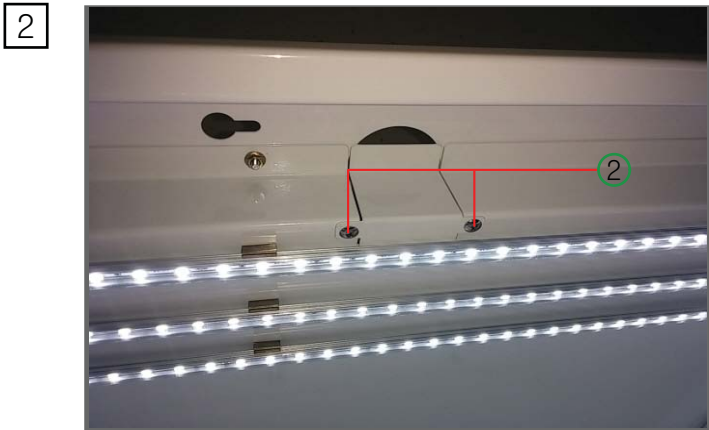

- After that, you will find ② main cabinet support cover brackets when you open front door.

Please disconnect M4 bolts in 2 spots using a tool.

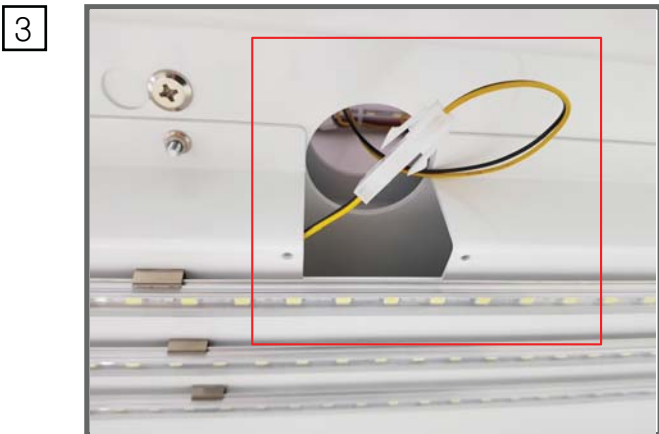

- After disconnecting M4 bolts, please connect the billboard connector with cabinet connector as shown in the photo.

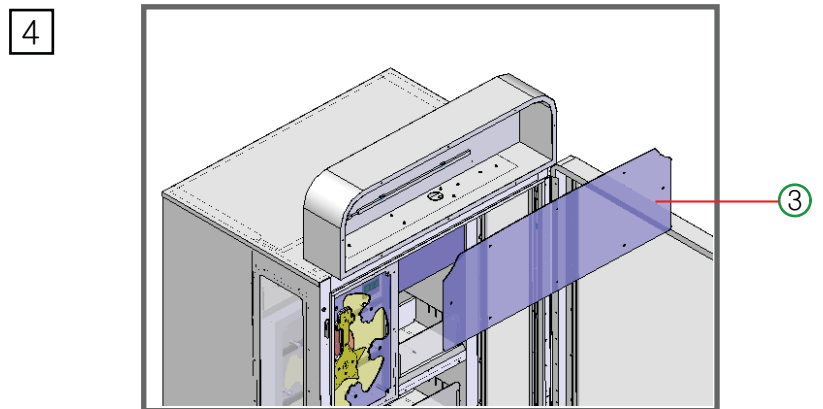

- Complete the billboard installation by assembling ② the main cabinet top support cover bkt & ③ BILLBOARD FRAME COVER ACRYL.

## 2-5. HOW TO INSTALL

1

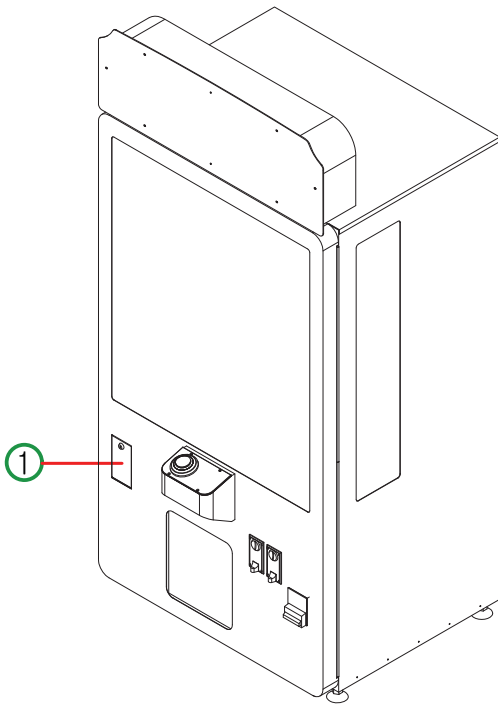

- ① Open door using door key.

3

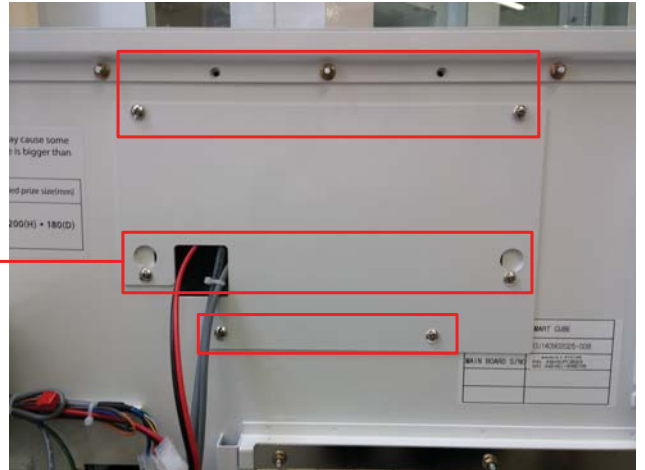

\* BUTTON FRAME PART +  
FRONT DOOR BUTTON CASE REAR COVER

- After fasten bolt in Button panel Ass'y, hang it on cabinet using holes (2Ea: ②). Then fasten rest of bolts (M4 bolt x 8Ea). Connect main connector with cable from button panel ass'y

4



- Complete the Ass'y as shown picture.

2

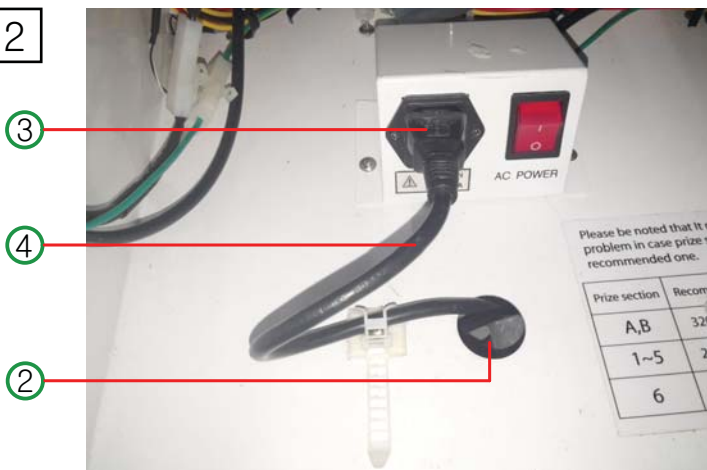

- Connect AC Cord in Control panel ③ through internal hole ② and fix it with cable tie ④.



# 3. SETUP SETTINGS

## 3-1. MACHINE SETUP

### 1. HOW TO ENTER SETUP MENU

- 1 There is "Control panel" inside cabinet. User may set any setting using following.

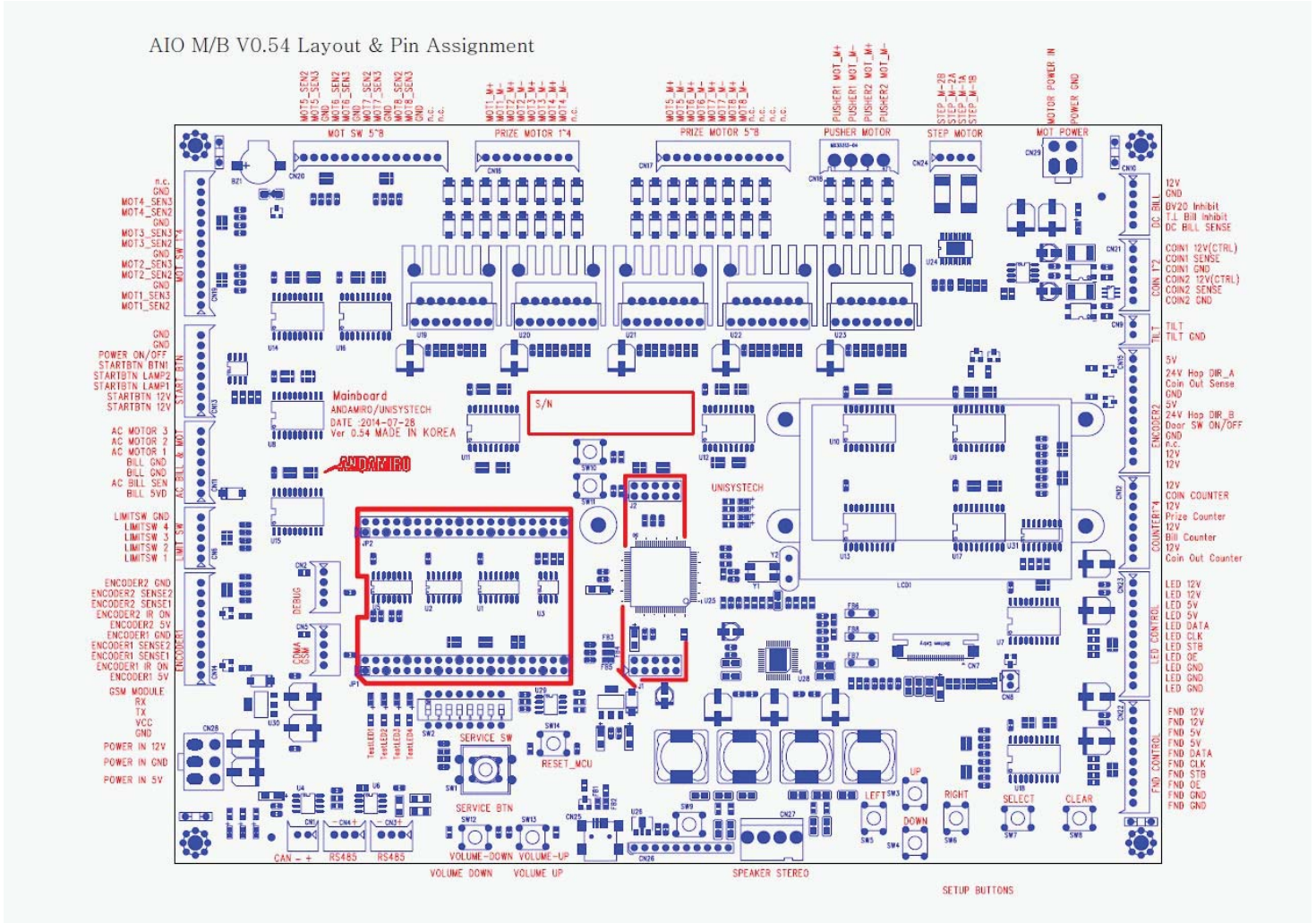

### [ MAIN PCB ]

## 2. SOUND VOLUME

- On the left below of AIO(All-In\_One) Mainboard, 2 buttons for Sound Volume of the game exist. Left button to lower volume, Right button to higher it. The basic set value is **88**. It is adjusts by 2, you can set from 0~100. If you push the button on TOTAL STATUS Window, the Volume value shows as belowed Window in a moment and then come back to the original screen.

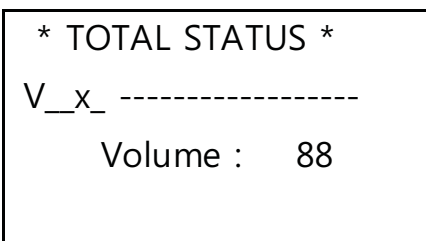

### 3. SERVICE BUTTON

- On the below of CPU in AIO Mainboard, there is a button for providing the Free Credit or the Credit for Gaming in a case of Test.

For each punching the button, Play Credit is increasing by 1. Counter Meter does not being increased.

### 4. SETUP LCD & SET BUTTON

- The SETUP LCD on the right side of AIO Mainboard has functions for checking the machine status or changing, saving and testing the suser set value.

When you power on, below screen shows and Program Version displays.

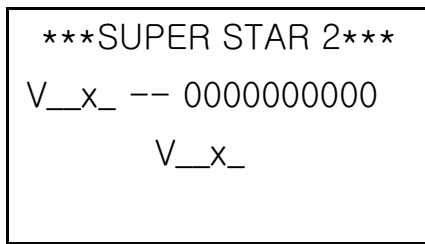

GSM Version

### 5. BUTTON INSTRUCTIONS FOR USE

- There are 6 buttons of UP/DOWN/LEFT/RIGHT/SELECT/CLEAR.

ALL buttons can perform different fuctions depending on whether it's a short press or long-key (a long press & hold) on the button(s).

[ ↑↓ ] Up/Down Button : After pressing SELECT Button, change value (-/+), ON/OFF change in case of pressing a button as long key, Changing Value becomes big.

[ ← → ] Left/Right Button : change set menu.

SELECT Button : To select desired menu / changing Set Value

CLEAR Button : To reset to Factory Setting / Calibration

**\* The First thing to do after installing a SUPER STAR2 and trying to operate it for the first time is to perform Calibration.**

**Calibration is testing the fuctions of components and can affect the seetting of the payout rates.**

**Calibration can be performed by Calibration of SET MENU.**

## 3-2. STATUS MODE : DIPLAYING AT ALL TIME ON GAME

### 1. COIN COUNT

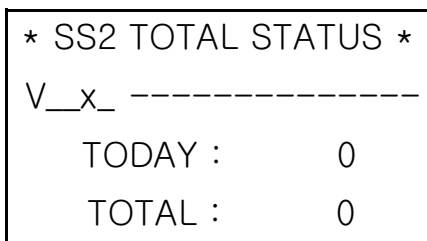

- 'TODAY' DISPLAYS THE INSERTED COINS AFTER OPERATORS INITIALIZE THE STATUS

- 1) On the field, Operator can initialize by long-key on [Clear] Button
- 2) Or by performing "Initialize setup"

**'Total' is total inserted coins**, It is impossible to erase and it can not be erased.

### 2. TOTAL PRIZE OUT : TOTAL GAME PLAYED TIMES

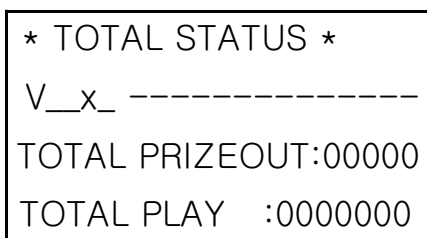

- **'TOTAL PRIZE OUT' is total Quantity of Prizes out**

- 1) On the field, Operators can initialize by long-key on [CLEAR] button
- 2) Or by performing "Initialize setup"

If it succeeds, the prize of allocated holes will be dispensed and 1 will be added when the Pusher bar comes back to origin point

**'TOTAL PLAY' is total game played times**, Bonus games also include. It is impossible to erase and it can not be erased.

### 3. CREDIT COUNT

```

* TOTAL STATUS *
V__x_-----
  CREDIT COUNT
    00  +00
  
```

Displays a two-digit display, up Credit Limit set by the Set Menu. Front amount of 00 is actual inserted coins quantities, Rear amount of +00 is Service Coins quantities. The front panel displays the combined quantity of gaming Credit FND has.

### 4. CREDIT / BONUS PLAY COUNT

In case of Card System, it is displayed as follows.

```

* SS2 TOTAL STATUS *
V__x_-----
  COIN : 00000000
  BONUS : 00000000
  
```

COIN displays the total amount of PLAY actually earned based on the number of card swipes. BONUS displays the total amount of BONUS PLAY earned when setting a bonus play based on the number of card swipes.

```

* SS2 TOTAL STATUS *
V__x_-----
  BILL : 00000000
  BONUS : 00000000
  
```

BILL displays the total amount of PLAY actually earned for one banknote inserted. BONUS displays the total amount of BONUS PLAY earned when setting a bonus payment for one banknote entered.

### 5. HOLE GAME PERFORMING STATUS (1~7, BY ROW NUMBER)

<pre> * HOLE STATUS:1 * V__x_--0000000000   PRIZE OUT  TOTAL     0      00000   </pre>	<pre> * HOLE STATUS:2 * V__x_--0000000000   PRIZE OUT  TOTAL     0      00000   </pre>	<pre> * HOLE STATUS:3 * V__x_--0000000000   PRIZE OUT  TOTAL     0      00000   </pre>
		<pre> * HOLE STATUS:4 * V__x_--0000000000   PRIZE OUT  TOTAL     0      00000   </pre>
<pre> * HOLE STATUS:5 * V__x_--0000000000   PRIZE OUT  TOTAL     0      00000   </pre>	<pre> * HOLE STATUS:6 * V__x_--0000000000   PRIZE OUT  TOTAL     0      00000   </pre>	<pre> * HOLE STATUS:7 * V__x_--0000000000   PRIZE OUT  TOTAL     0      00000   </pre>

Displays Prize Out q'ty of the holes and the attempted times of each hole. Being switched to LOW with {Up}, {Dn} Button

## 6. TILT(SHAKE) ERROR COUNTS

```
* ERROR TILT=00X *
V_x_ -----
      CREDIT COUNT
      00 +00
```

### X : Error Tilt error counts

Tilt Error is when the machine get some outside shock. When Tilt gets contacts more than 1 time, Error Event will proceed for 10 secs and then transfer to the normal mode.  
Press [CLEAR] button to initalize the TILT ERROR count.

The machine will be initialized when credits remain.

If possible, please do not initialize the machine when credits remain. The machine will be initialized even when executing "Initial setup".

### 3-3. SET MENU : PRESS AND HOLD [SELECT] BUTTON IN STATUS MODE

#### 1. VERSION DISPLAY

```

* SS2 SET MENU *
V__x_ -----
*** SUPER STAR2 ***
ANDAMIRO V__x_
    
```

#### 2. PRIZELOADER REMOVE FUNCTION

In case of malfunction of PrizeLoader or parts such as MOTOR, FRONT/REAR SW, the function of PrizeLoader Module for a specific prize cell can be disabled.

In case players target the stopped hole, the pusher bar will return to home instead of moving forward at a whole stopped location of the hole concerned. Credit will be reduced by 1.

<pre> * SS2 SET MENU * V__x_--0000000000 Hole X-1 PrizeLoader Enabled                     </pre>	<pre> * SS2 SET MENU * V__x_--0000000000 Hole X-2 PrizeLoader Enabled                     </pre>	<pre> * SS2 SET MENU * V__x_--0000000000 Hole X-3 PrizeLoader Enabled                     </pre>
		<pre> * SS2 SET MENU * V__x_--0000000000 Hole X-4 PrizeLoader Enabled                     </pre>
<pre> * SS2 SET MENU * V__x_--0000000000 Hole X-5 PrizeLoader Enabled                     </pre>	<pre> * SS2 SET MENU * V__x_--0000000000 Hole X-6 PrizeLoader Enabled                     </pre>	<pre> * SS2 SET MENU * V__x_--0000000000 Hole X-7 PrizeLoader Enabled                     </pre>

- 1) "[Enabled]" displays, when you push [SELECT] Button and then enter into the function change mode.
- 2) Change the value with {^},{v}Button
- 3) On the screen, it displays as below. (Example 1 hole)

```

*SET MENU *
[Disabled: 1      ]
Hole X-1 PrizeLoader
[Disabled]
    
```

- 4) Press [SELECT] button to disable the specified prize cell.
- 5) Is displayed on all the screen is still Prizebox.

```

* TOTAL STATUS *
[Disabled: 1      ]
TODAY :          0
TOTAL :          0
    
```

- 6) In order to recover the function after repairing PrizeLoader, change the probability of the allocated hole into the value you want.

### 3. CHANGING CALIBRATION STARTING POSITION

```
* SS2 SET MENU *
V__x_ -----
      Offset:   0
```

In calibration, you may adjust starting position if it's located right side of target.

- 1) Setting range is **-20 ~ +20** (Default : **0**).
- 2) Press [SELECT] button to access the menu. It displays as (Default : **0**).
- 3) Change the Values by [Up],[Dn]Button.  
{Up} : Increase, {Dn} : Decrease
- 4) If you set (-) value, the origin point moves more left to the basic location. If you set (+) value, the origin point moves more right to the basic location.
- 5) Press [SELECT] button to save all changes.

### 4. 1 PLAY COIN NUMBER

```
* SS2 SET MENU *
V__x_ -----
Credit  Coin  Set
      1 Credit  4 Coin
```

Set coin number for 1 Play, 1 coin = 25 ¢

※ You may set 1 Credit 2 Play. The setting is 2 Credit 4 Coin.

- 1) Default is 1 Play 1\$, it is 4 in case of 4 Coin setting, It may change 1~10, 2 Credit 4 Coin.  
When the setting value is set to 1 (1 credit, 1 coin), it is set to Card System.
- 2) Press [SELECT] Button to enter to the change mode, "[ 4]" displays.
- 3) Change the values by [Up],[Dn]Button.  
{Up} : Increase, {Dn} : Decrease

### 5. COIN (CARD SWIPE) BONUS PLAYS PAYMENT SETTINGS

<pre>* SS2 SET MENU * V__x_ ----- Bonus Plays Set       1-Swipes= 1 Plays</pre>	<pre>* SS2 SET MENU * V__x_ ----- Bonus Plays Set       2-Swipes= 2 Plays</pre>	<pre>* SS2 SET MENU * V__x_ ----- Bonus Plays Set       3-Swipes= 3 Plays</pre>
<pre>* SS2 SET MENU * V__x_ ----- Bonus Plays Set       4-Swipes= 4 Plays</pre>	<pre>* SS2 SET MENU * V__x_ ----- Bonus Plays Set       5-Swipes= 5 Plays</pre>	

This is the credit value generated when you continuously swipe the card without playing it on the card reader, and you can set Bonus Play. The default value is each displayed value and can be changed from **1** to **20**.

- 1) When you press the [SELECT] Button, it enters change mode and is displayed as "[ 1]".
- 2) Change the values by [Up],[Dn]Button.  
{Up} : Increase, {Dn} : Decrease
- 3) After changing the value, press the [SELECT] Button.
- 4) It cannot be set smaller than the default setting. You can keep the default settings or set them larger.

### 6. 1 BILL COIN NUMBER

```
* SS2 SET MENU *
V__x_ -----
Coin per Bill
      1-Bill= 4 Coin
```

Coin Pulse Number for 1 Bill, default is **2**, It may change **1~10**

- 1) Press [SELECT] Button to enter to the change mode, "[ 4]" displays.
- 2) Change the values by [Up],[Dn]Button.  
{Up} : Increase, {Dn} : Decrease
- 3) Press [SELECT] Button to save all changes.

## 7. PLAYS/BILL SETTINGS

```

* SS2 SET MENU *
V__x_-----
  Credit  Bill Set
    1 Credit  2 Bill
    
```

Set the amount for 1 Play (based on Bill). If it is 2\$, it is set to 2 Bill, and can be changed from 1 to 10.

1) When you press the [SELECT] Button, it enters change mode and is displayed as “[ 4]”.

2) Change the value with the [Up] and [Dn] Buttons.

[Up]: Increase, [Dn]: Decrease

3) After changing the value, press the [SELECT] Button.

## 8. BILL CREDIT/BONUS PLAYS PAYMENT SETTINGS

In the bill/bonus payment settings, the Bill value is displayed in conjunction with the Bill value in the PLAY/BILL setting items above.

- If the Bill value in the above PLAYS/BILL setting item is 1, the Bill value is displayed as 1 Bill, 2 Bill, 3 Bill to 10 Bill in the bill/bonus payment settings.
- If the Bill value in the above PLAYS/BILL setting item is 2, the Bill value is displayed as 2 Bill, 4 Bill, 6 Bill to 20 Bill in the bill/bonus payment settings.
- If the Bill value in the YS/BILL setting item is 3, the Bill value is displayed as 3 Bill, 6 Bill, 9 Bill to 30 Bill in the bill/bonus payment settings.
- Since the default Bill value of the above PLAYS/BILL setting item is 2, it is displayed as below.

<pre> * SS2 SET MENU * V__x_-----   Bill Bonus Plays Set     1-Bill= 1 Plays           </pre>	<pre> * SS2 SET MENU * V__x_-----   Bill Bonus Plays Set     2-Bill= 3 Plays           </pre>	<pre> * SS2 SET MENU * V__x_-----   Bill Bonus Plays Set     3-Bill= 5 Plays           </pre>
<pre> * SS2 SET MENU * V__x_-----   Bill Bonus Plays Set     5-Bill= 8 Plays           </pre>	<pre> * SS2 SET MENU * V__x_-----   Bill Bonus Plays Set     10-Bill= 17 Plays           </pre>	<pre> * SS2 SET MENU * V__x_-----   Bill Bonus Plays Set     20-Bill= 35 Plays           </pre>

The bill machine is set to accept \$1, \$2, \$5, and \$10.

This is the Credit Value generated based on the accumulated amount when bills are continuously inserted into the banknote machine without play. Bonus Play can be set.

The default value is each displayed value and can be changed from 0 to 20.

1) When you press the [SELECT] Button, it enters change mode and is displayed as “[ 1]”.

2) Change the value with the [Up] and [Dn] Buttons.

3) After changing the value, press the [SELECT] Button.

4) It cannot be set smaller than the default setting. You can keep the default settings or set them larger.

## 9. CREDIT LIMIT SET

```

* SS2 SET MENU *
V__x_-----
  Credit Limit
    Max Credit= 40
    
```

Default is 40, it may change 1~100

Coin mech becomes "Inhibit" in case coin is inserted more than the setting.

## 10. PLAY TIME LIMIT SET

```
* SS2 SET MENU *
V_x_ -----
Time Limit
    30 Sec
```

Set and change Game playing time for 1 Play. Default is 30, It may change 10~60.

After swiping a CARD or inserting a BILL, the number displayed in TIME decreases. If you do not start the game, the game is played at the home location and Credit is decreased by 1. You must play the game quickly within 30 seconds.

## 11. DEMO SOUND

```
* SS2 SET MENU *
V_x_ -----
Demo Sound
    On
```

Demo Sound On/Off set/change  
Default=On

## 12. EXAMPLE SETTING FOR PRIZELOADER ON

```
* SS2 SET MENU *
V_x_ -----
Prize Show-off
    Off
```

Setting Modes for moving Pusher Bar on forward/backward in front of the PrizeLoader of allocated hole when you stop the push bar on any hole location on game.

- PrizeLoader example forward mode On/Off Setting.
- Default=off ( example function of moving forward a little and backward )

## 13. SAVE & EXIT

```
* SS2 SET MENU *
V_x_ -----
Save & Cancel
Press [SEL] & [CLR]
```

Press [SELECT]Button to save and exit.  
Press long key [CLEAR]Button to exit without saving.



### 3-4. Press and hold UP & DOWN buttons at the same time to enter "TEST MENU" .

#### 1. CHECKING HOLE POSITION(S)

\*\*\* Check the calibration hole location.

```
* SS2 SET MENU *
V__x_ -----
Test Target
Press CLEAR Button
```

Press the [CLEAR]Button to start the test.

When running Test Target, "ts" is displayed in the FND on the front of the game machine, and "tn" is displayed in the TIME FND. "n" refers to the number of each hole. Once completed, the main screen for entering the test menu is displayed.

If it fails, the position is wrong, so calibration must be performed.

Press the [CLEAR] Button, first, at the bottom of the consoles has yeodat 4th Prize Door.

#### 2. CALIBRATION

\*\*\* Calibrate the hole position of the game machine. Only calibration-related data is changed and saved.

```
* SS2 SET MENU *
V__x_ -----
Calibration
0 (CLR=Reset)
```

When you press the [CLEAR] Button, first open and close the Prize Door at the bottom of the game machine four times.

```
* SS2 TEST MENU *
V__x_ -----
PROGRESS...
```

The calibration screen is as shown below, and indicates the number of successes for each hole. The default value is 1 to 3 times. times.

```
* SS2 TEST MENU *
V__x_ -----
Hole: 1 2 3 4 5 6 7
CNT: 0 0 0 0 0 0 0
```

When performing calibration, "Ca" is displayed on the FND on the front of the game console, and "tn" is displayed on the TIME FND. "n" refers to the number of each hole.

When completed, "do" will be displayed on the FND on the front of the game machine, and "nE" will be displayed on the TIME FND.

Finish by pressing the [SELECT] Button and exit to item mode.

**Notice 1 :** When succeeding each hole at a first try without a failure or succeeding at a second try, the number of success of the related holes is displayed on the screen and the process of Error Event will start.

And then the machine stops after displaying Error Code "EE CA" on FND. Turn off the machine and adjust the Arrow, and then proceed with Calibration. The process is as above.

**Notice 2 :** When the number of success of each hole exceeds 3 times, the number of success of the related hole is displayed on the screen and the process of Error Event will start. And then the machine stops after displaying Error Code "EE CA" on FND. Turn off the machine and check the condition of Arrow. Replace the Arrow if it is worn-out or damaged and then proceed with calibration. The process is as above.

### 3. Prize Motor Test

```
* SS2 TEST MENU *
V__x_ -----
Prize Motor
    ALL (CLR=PUSH)
```

\*\*\* Test each prize motor/switch installed on PrizeLoader dispensing Prizes.

1) Default is "ALL". If you press [CLEAR]Button, 7 motors in PrizeLoader operate at a time and move forward and test them. all of 7 PrizeLoaders stop when Front SW in PrizeLoader is switched.

```
* SS2 TEST MENU *
V__x_ -----
Prize Motor
    ALL (CLR=PUSH)
```

To return back to the origin position, press [CLEAR]Button again. Then 7 motors in PrizeLoader move backward all of 7 PrizeLoaders stop when Rear SW in PrizeLoader is switched. The test will repeat everytime when you press [CLEAR]Button.

2) Press [SELECT] Button to select PrizeLoader and then enter into PrizeLoader select mode. "[ALL]" displays.

3) When you press [CLEAR]Button after choosing PrizeLoader for testing by [Up],[Dn]Button, allocated PrizeLoader moves forward and perform the same process.

## 4. Pusher Box Motor/Sensor Test

```
* SS2 TEST MENU *
V_x_ -----
Motor Test
Press SELECT Button
```

\*\*\* Testing all motors and sensors installed in Pusher Box by moving Pusher Box on left, right or front, rear.

Press [SELECT] Button and next screen displays, It means Test Mode is activated, Prizeout Door is closed. Origin position is recognized.

```
* SS2 TEST MENU *
V_x_ -----
  -- S2 X0 RL -- --
Press CLEAR TO Exit
```

### 1) Pusher Box Motor/Sensor Test

If you press start button on the status like picture, Prizeout door will be open and display S1. And press start button again, prizeout door will be closed and display S2.

S1 : Door Open SW ON, S2 : Door Close SW ON

### 2) Pusher Box Motor/Sensor Test

2-A) For Pusher box testing, button function for moving pusher box are as below

{<} : move left, {>} : move right  
{Up} : forward, {Dn} : backward

2-B) Once a sensor perceives movement of pusher Box, relevant sensor will be displayed. Then next sensor will be activated. After moving again and if other sensors are recognized, the previous sensor will be shown as "-- "

2-C) 4 options display

X0: Origin Sensor, RL:Rear Sensor, ML: Middle Sensor(Fail), FL: Front Sensor(Success)

```
* SS2 TEST MENU *
V_x_ -----
  S1 S2 X0 RL ML FL
Press CLEAR TO Exit
```

3) After finishing Motor/Sensor Test, press [CLEAR]Button and then move to [Motor Test] menu screen.

## 4. LED Test

```
* SS2 TEST MENU *
V__x_ -----
LED = Off
Press SEL/Left/Right
```

\*\*\* The LED test tests the LED, which is a flashing indicator element in a gaming console. The screen looks like this:

When you press the [SELECT] Button, the following screen appears and Test Mode is activated.

```
* SS2 TEST MENU *
V__x_ -----
LED = [BLACK ]
Press SEL/Left/Right
```

Each time you press the [Right] Button, it changes sequentially in the following order:  
RED/GEEN/BLUE/WHITE/MAGENTA/CYAN/YELLOW/BLACK.

Pressing the [SELECT] Button stops the LED Test and returns to the upper screen.

## 5. Media Test

\*\*\* The LED test tests the LED, which is a flashing indicator element in a gaming console.  
The screen looks like this:

```
* SS2 TEST MENU *
V__x_ -----
FND,Sound= Off
Press SEL/Left/Right
```

When you press the [SELECT] Button, the following screen appears and Test Mode is activated.

```
* SS2 TEST MENU *
V__x_ -----
FND,Sound = [Off]
Press SEL/Left/Right
```

### 1) FND Test

Numbers 0 to 9 are displayed sequentially in FND.

### 2) Sound Test

When you press the [Right] Button in the screen above, Sound=[001] is displayed and the sound is played through the speaker. When you press the [Right] Button again, the number increases and the sound is played through the speaker.

When you press the [Left] Button, the number decreases and the corresponding sound is played through the speaker.

Pressing the [SELECT] Button stops the FND Test and returns to the upper screen.

## 6. Counter Test

\*\*\* The Count Test tests the two counters, COIN COUNTER and PRIZE COUNTER, located at the bottom center of the game machine. The screen is as follows.

```
* SS2 TEST MENU *
V_x_ -----
Left-CNT1  Right-CNT2
Press Left/Right BHn
```

When you press the [Left] Button in the screen above, the number of COIN COUNTER increases by 1.  
When you press the [Right] Button, the number of PRIZE COUNTER increases by 1.  
The increased number of counters cannot be reversed, so please refrain from excessive testing.

## 7. FACTORY INITIALIZE

```
* SS2 TEST MENU *
V__x_ -----
Factory Initialize
Press CLEAR Button
```

\*\*\* All setting becomes the factory default status and then perform Calibration.

Press the [CLEAR] Button, first, at the bottom of the consoles has yeodat 4th Prize Door.

```
* SS2 TEST MENU *
V__x_ -----
*Factory Initializing*
Wait a Moment...
```

Hole check screen as like below, the succeed times of each hole is 1~3 times. Only below 4 times are allowed

```
* SS2 TEST MENU *
V__x_ -----
Hole: 1 2 3 4 5 6 7
CNT: 0 0 0 0 0 0 0
```

When running Hole Check, "Ca" is displayed on the FND on the front of the game console, and "tn" is displayed on the TIME FND. "n" refers to the number of each hole.

When completed, "do" will be displayed on the FND on the front of the game machine, and "nE " will be displayed on the TIME FND. Finish by pressing the [SELECT] Button and exit to item mode.

**Notice 1 :** When succeeding each hole at a first try without a failure or succeeding at a second try, the number of success of the related holes is displayed on the screen and the process of Error Event will start.

And then the machine stops after displaying Error Code "EE CA" on FND. Turn off the machine and adjust the Arrow, and then proceed with Calibration. The process is as above.

**Notice:** If the number of successes for each hole exceeds 3, the number of successes for that hole is displayed on the screen, an Error Event occurs, "EE CA" Error Code is displayed on the FND, and the game machine stops.

Turn off the game console, check the arrow for wear or damage, replace the arrow, and perform calibration again. The process is as above.

## 8. INITIALIZING SET-UP VALUES

```
* SS2 TEST MENU *
V__x_ -----
Initialize Setup
Press CLEAR Button
```

\*\*\* Initialize all settings of "Set Menu" and some game data.

Press [CLEAR] Button, all settings in "Set Menu" and some game data are initialized. Calibration/Total is not affected.



## 9. SAVING THE TEST MENU AND EXIT

```
* SS2 TEST MENU *
V__x_ -----
Save & Cancel
Press [SEL] & [CLR]
```

Press [SELECT]Button. Save setting and exit.  
Press [CLEAR]Button with Long-Key. Exit without saving.

### 3-5. ERROR CODE

In case error occurs in the middle of machine operating, Super Star show ERROR CODE, ON MACHINE FRONT FND. ERROR CODE, DESCRIPTION AND TROUBLE SHOOTNG ARE AS BELOW.

ERROR CODE	CONTENT	STATUS
1. EE-12	<p>Home(Origin) Return Error            - This Error code is generated in case of you cannot check the origin point due to origin point switch error or motors malfuction because the origin switch should be detected when you turn on the power or PusherBox returns back to origin point(Home) during the machine operation.            Check and change the Origin switch or motor connected with PusherBox on back side of taregt Acryl inside of the machine.</p>	ERROR EVENT, STOP
2. EE-AC	<p>Prize Out Door Error ( In case all switches are pressed or no checking)            - This Error code is generated in case of the prize door is closed when you turn on the power or the prize door is not working because the Prize door on the down side of the game should be opened and closed to dispense the prize when a game succeeds.            Check and change the switch or motor connected with Prize Door.</p>	ERROR EVENT, STOP
3. 	<p>Prize Out Door Close S/W. Error            - This Error code is generated in case of the prize door is not stoped at normal position or not working properly. In case of the prize door is closed when you turn on the power or when the game is succed, prize door on the down side of machine should be closed after dispensing the prize.</p>	ERROR EVENT, STOP
4. 	<p>Prize Out Door Open S/W. Error            - This Error code is generated in case of the prize door on the down side of the machine is not opening properly when you turn on the power or in case of game success because the prize door should be opened when Prize-Loader dispense the prize.            Check and change the motor connected with Prize Door or the switch on open location (Rear SW.)</p>	ERROR EVENT, STOP
5. EE-Ln	<p>PrizeLoader Front S/W, Rear S/W Error n:Hole no.            1. When power is on. Front and Rear SW of Prizeloder are checked together in the process of initializing,            2. Front and Rear SW of Prizeloder are checked together on game mode or demo mode.            3. check and change the Front SW., Rear SW. the allocated prizeLoader.</p>	ERROR EVENT, STOP
6. EE-Fn	<p>PrizeLoader Front S/W or Motor Error n: Hole No.            - This Error code is generated in case of a prize is not dispensed when a game succeeds and then the prize loader forwards in order to dispense the prize.            Check and Change the motor on the back of PrizeLoader or the switch on Prizeloder(Front S,w)</p>	ERROR EVENT, STOP

<b>7. EE-rn</b>	PrizeLoader Rear S/W or Motor Error n: Hole No. - This error code is generated when you cannot check the origin point due to motor faulty or origin switch faulty because origin switch should be detected by returning back to origin point after the prizeloader dispenses a prize in case game succeeds or prizeloader is located at origin point when power is off.	<b>ERROR EVENT, STOP</b>
<b>8. EE-06</b>	Pusherbox Front/Back Moving Error, RARE SW ERROR - This Error code is generated in case of the bar of Pushbar succeeds but does not return back to Player direction after moving forward to the inner side. Check and Change the motor or the switch in the Pushbox.	<b>ERROR EVENT, STOP</b>
<b>9. EE-08</b>	Pusherbox Front/Back Moving Error, FRONT SW ERROR - This error code is generated in case the bar of pusher box does not retrun back to player direction cause the bar should be at plyer direction after moving forward when power is on or the machine is on operating. PusherBox Check and change inside motor or Front SW.	<b>ERROR EVENT, STOP</b>
<b>10. EE-15</b>	TILT Error - This Error code is generated in case of the machine is shaken or shocked. The machine will operate normally after performing the Error Event for 10 seconds.	
<b>11. EE-CA</b>	- Calibration ERROR  <b>Notice 1 :</b> When succeeding each hole at a first try without a failure or succeeding at a second try, the number of success of the related holes is displayed on the screen and the process of Error Event will start. And then the machine stops after displaying Error Code “EE CA” on FND. Turn off the machine and adjust the Arrow, and then proceed with Calibration. The process is as above.  <b>Notice 2 :</b> When the number of success of each hole exceeds 6 times, the number of success of the related hole is displayed on the screen and the process of Error Event will start. And then the machine stops after displaying Error Code “EE CA” on FND. Turn off the machine and check the condition of Arrow. Replace the Arrow if it is worn-out or damaged and then proceed with calibration. The process is as above.	<b>ERROR EVENT, STOP</b>



## 4. HOW TO REPLACE MAJOR COMPONENTS

### 4-1) REPLACING MAIN PCB

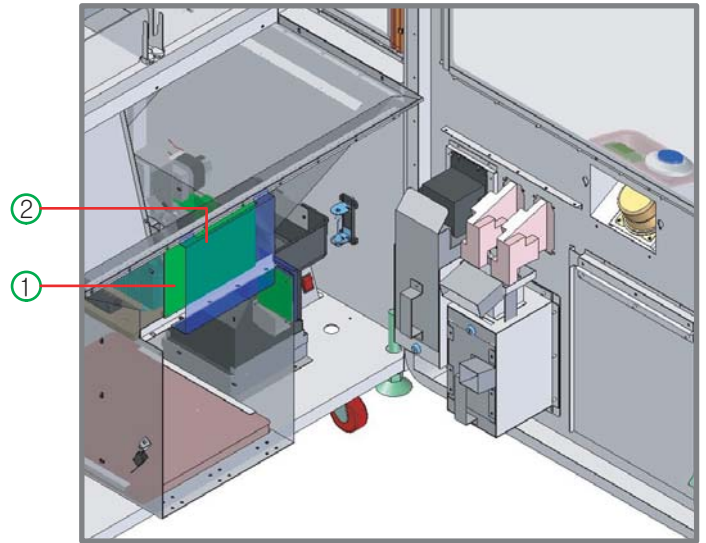
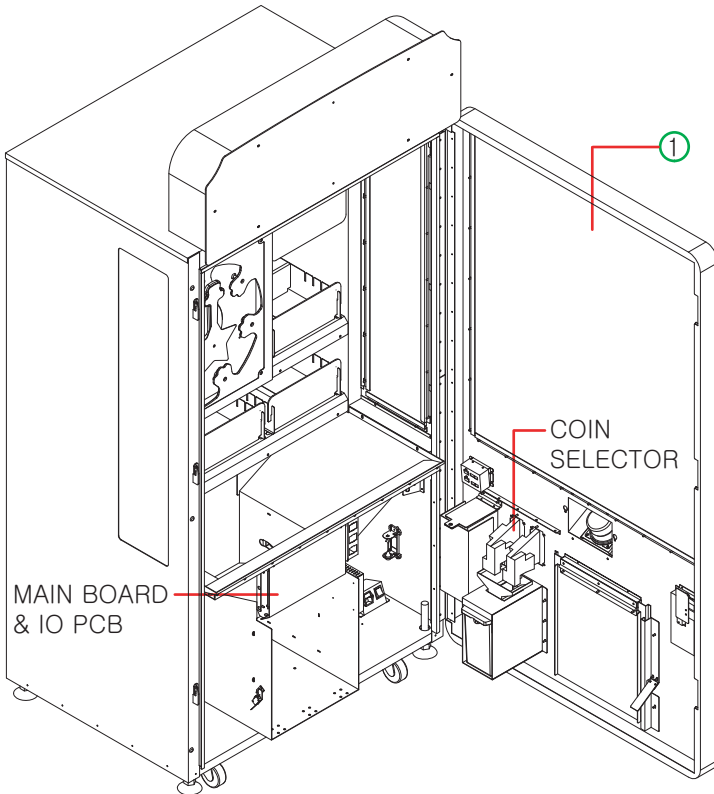

- (1) Open ① the front door.
- (2) ② Remove hand bolt (size:M4)
- (3) ③ Remove the connector between Main PCB, and then replace the Main PCB.
- (4) Re-assemble the parts in reverse order.

NO.	PART NAME	SPEC.	CODE NO.
②	MAIN PCB ASS'Y	-	AZZZ0PCB245

### 4-2) REPLACING COIN SELECTOR

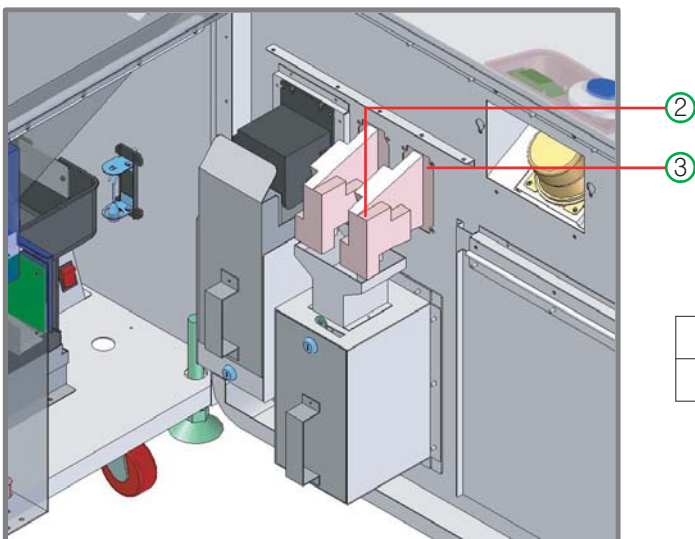

- (1) Open ① the front door.
- (2) ② Remove the connector.
- (3) ③ Remove eight bolts (size: M4) and nuts.
- (4) Re-assemble the parts in reverse order.

NO.	PART NAME	SPEC.	CODE NO.
④	COIN SELECTOR	-	-

\* Reassemble them in reverse order and check performance of the game.

## 4-3) REPLACING PRIZE DISPENSER PART & Z MOVING PART

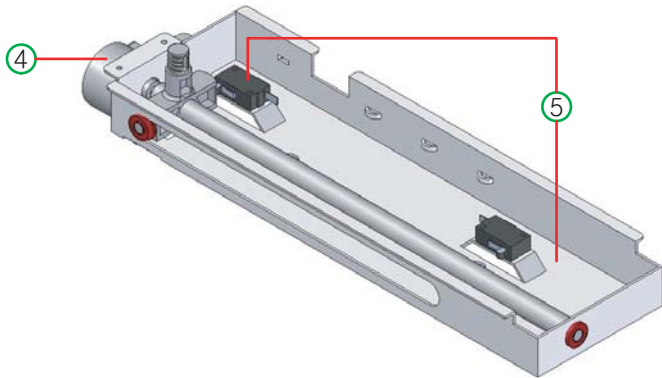
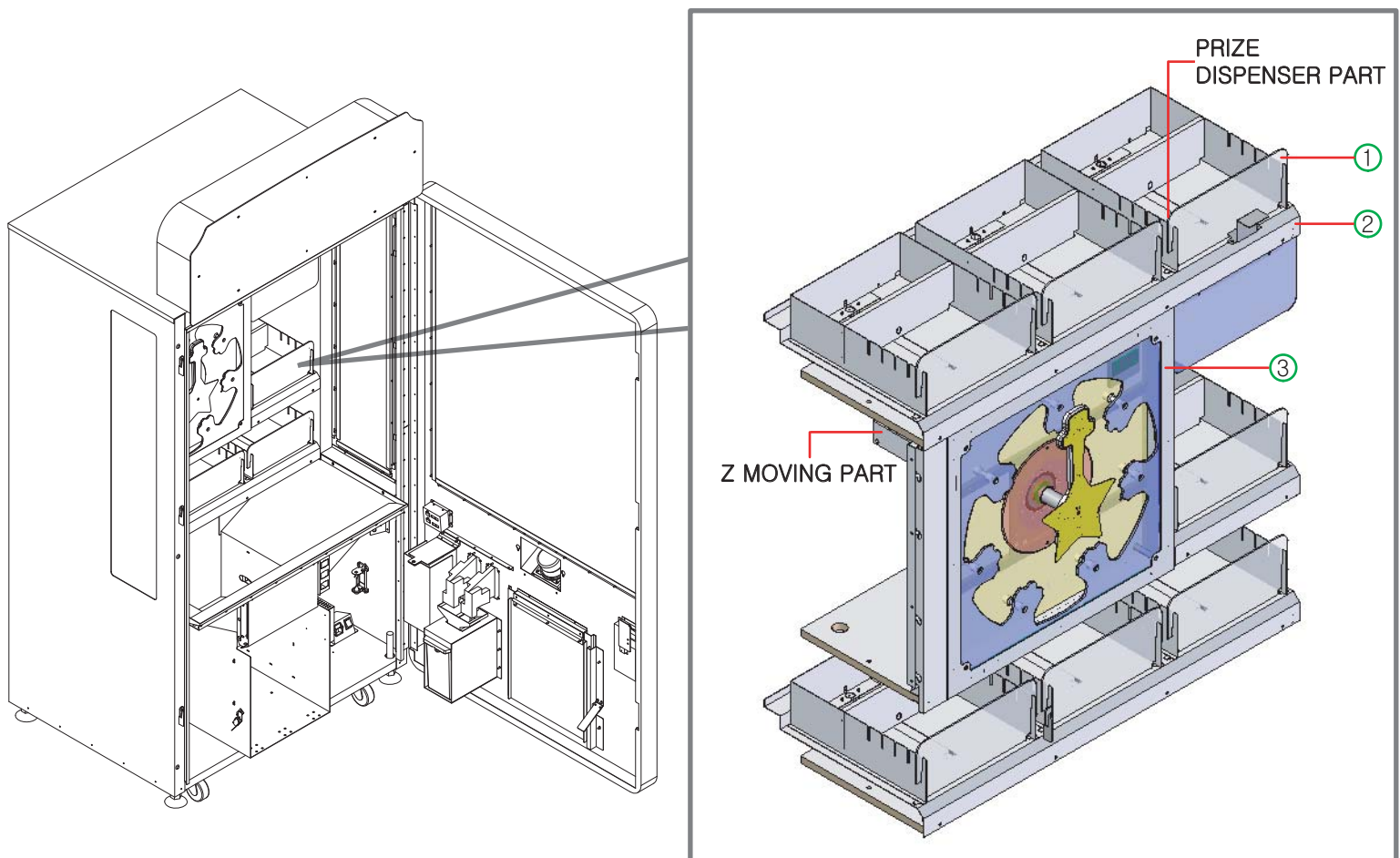

**PRIZE DISPENSER PART**

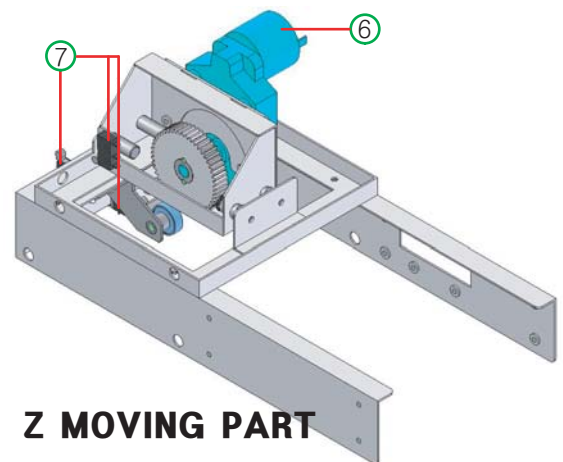

**Z MOVING PART**

### - PRIZE DISPENSER PART

- (1) Remove the ① prize dispenser cover then remove the ② prize dispenser.
- (2) Locate the prize dispenser parts inside.
- (3) Remove connector, then replace ④ motor or ⑤ micro switch.

### - Z MOVING PART

- (1) Remove ③ Target Display Part to locate Z-Moving part.
- (2) Remove the connector, then replace ⑥ motor or ⑦ Micro Switch.

NO.	PART NAME	SPEC.	CODE NO.
④	DC MOTOR	KWC_KD1-3429-095 (1:25)	MZZZ0MOT063
⑤	MICRO SWITCH	GSMV1651A2	MELE0MIC021
⑥	DC MOTOR	KGE-3429-050, 1/452	MZZZ0MOT082
⑦	MICRO SWITCH	SSM3142	MELE0MIC003

**\* Reassemble them in reverse order and check performance of the game.**

## 5. TROUBLESHOOTING

### 5-1. IN CASE OF POWER FAILURE

\*Common: Check the input voltage, check wiring

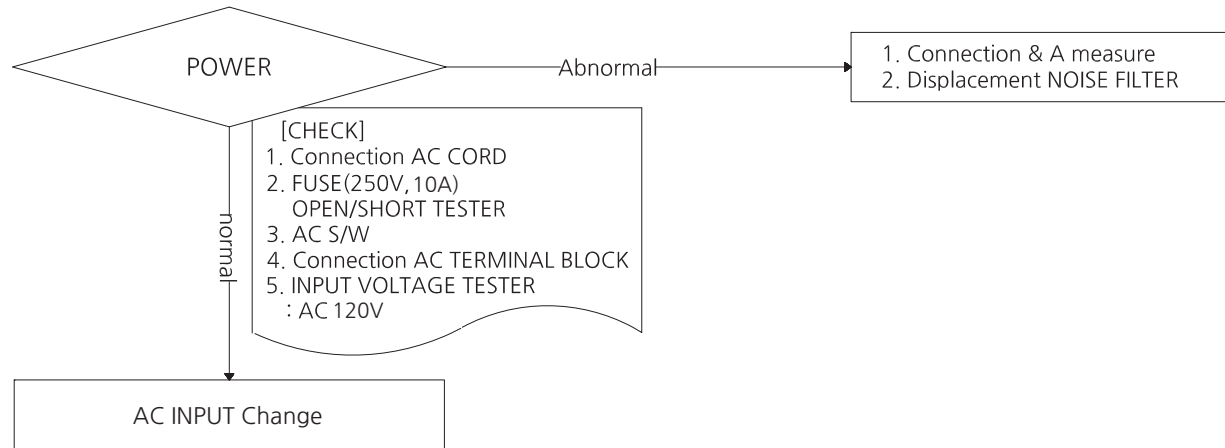

### 5-2. MOTOR ERROR

\*Common: Check the input voltage, check wiring

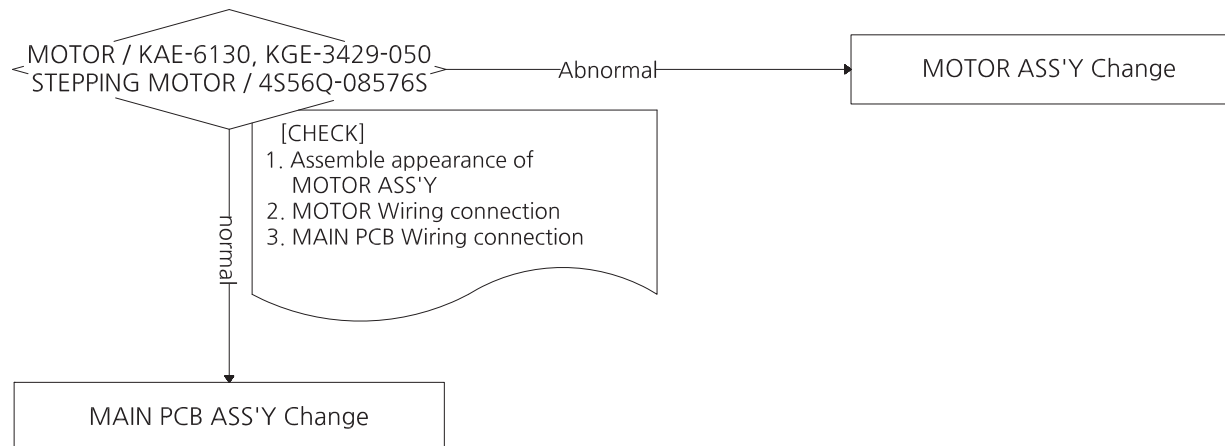

### 5-3. MICRO SWITCH ERROR

\*Common: Check the input voltage, check wiring

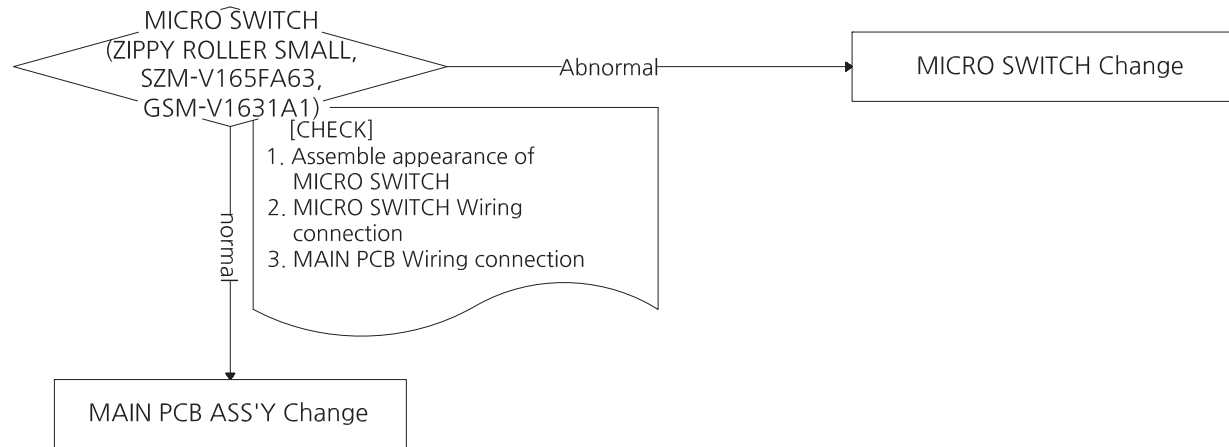

# 5-4. COIN SELECTOR ERROR

\*Common: Check the input voltage, check wiring

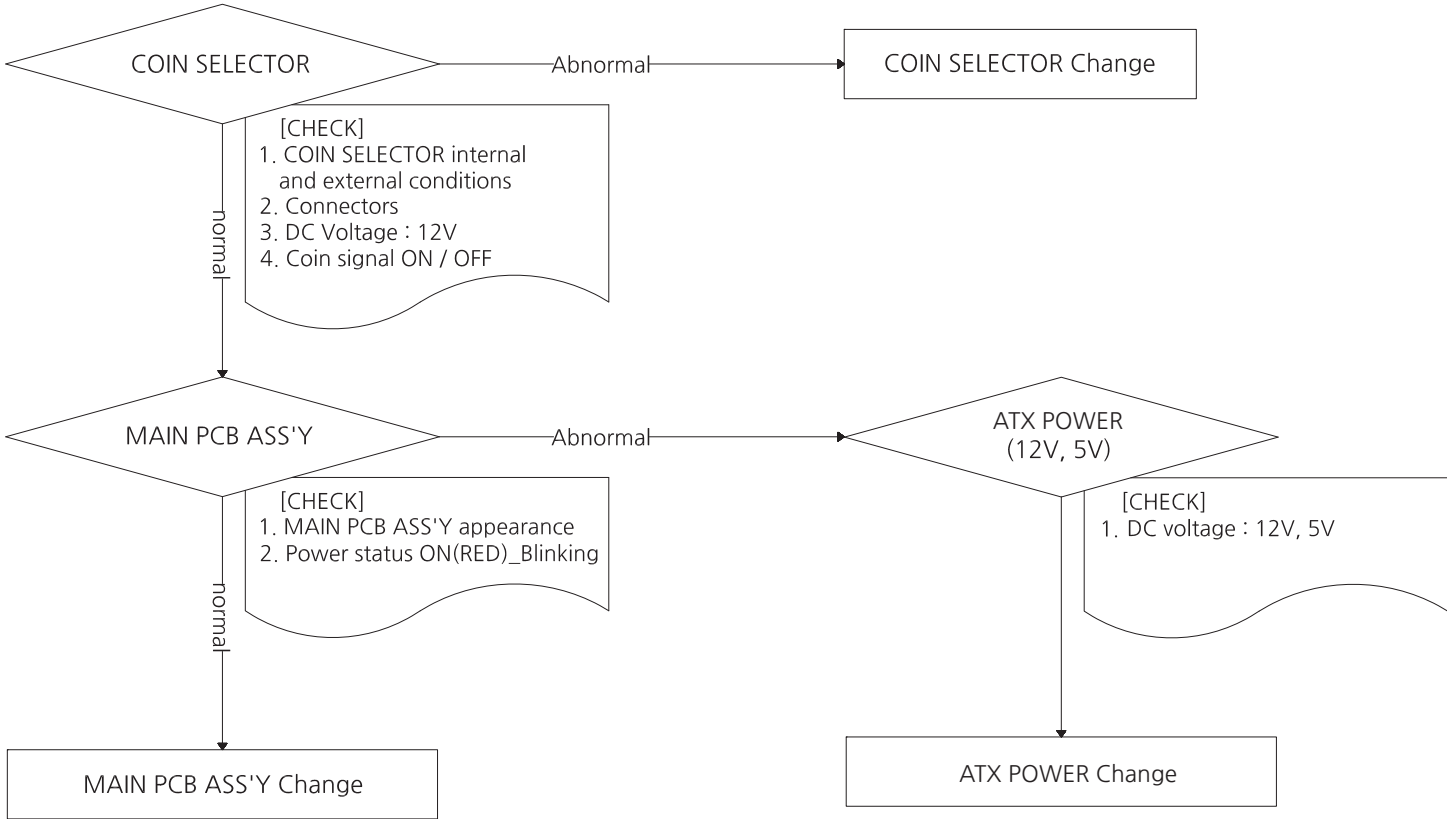

# 5-5. SOUND ERROR

\*Common: Check the input voltage, check wiring

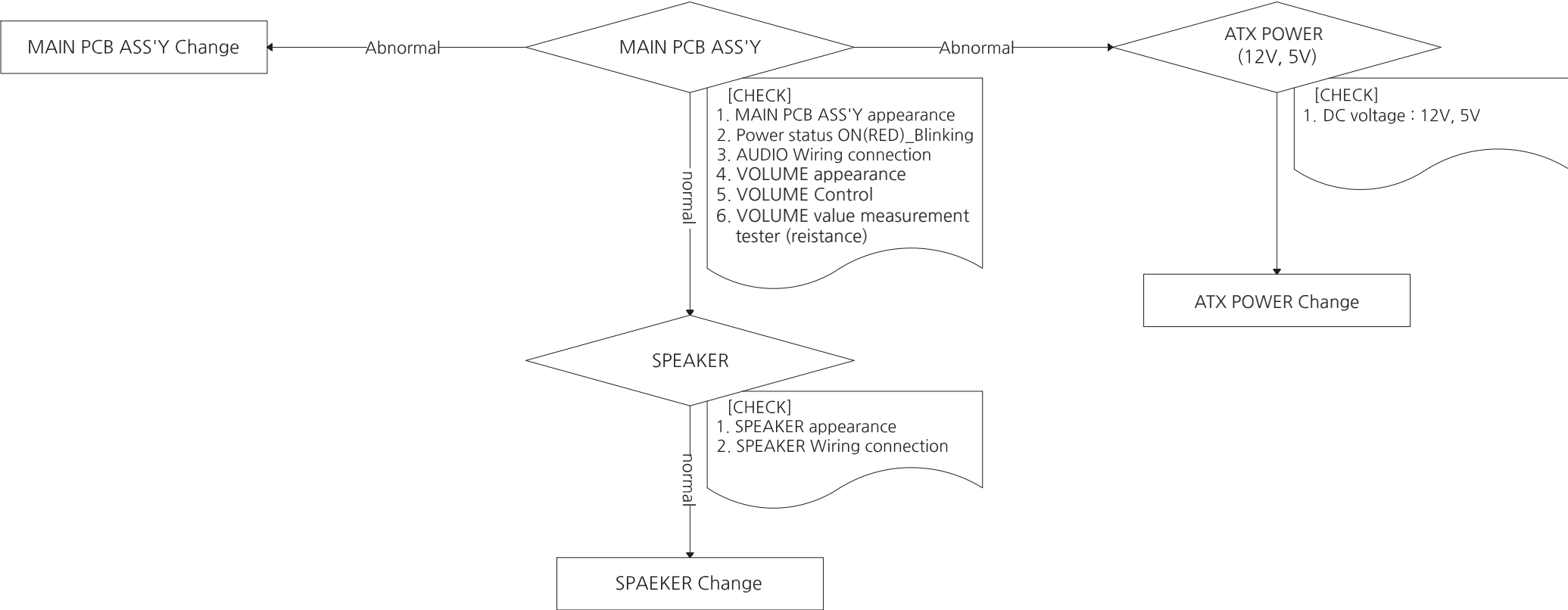

# 5-6. BUTTON & COUNTER ERROR

\*Common: Check the input voltage, check wiring

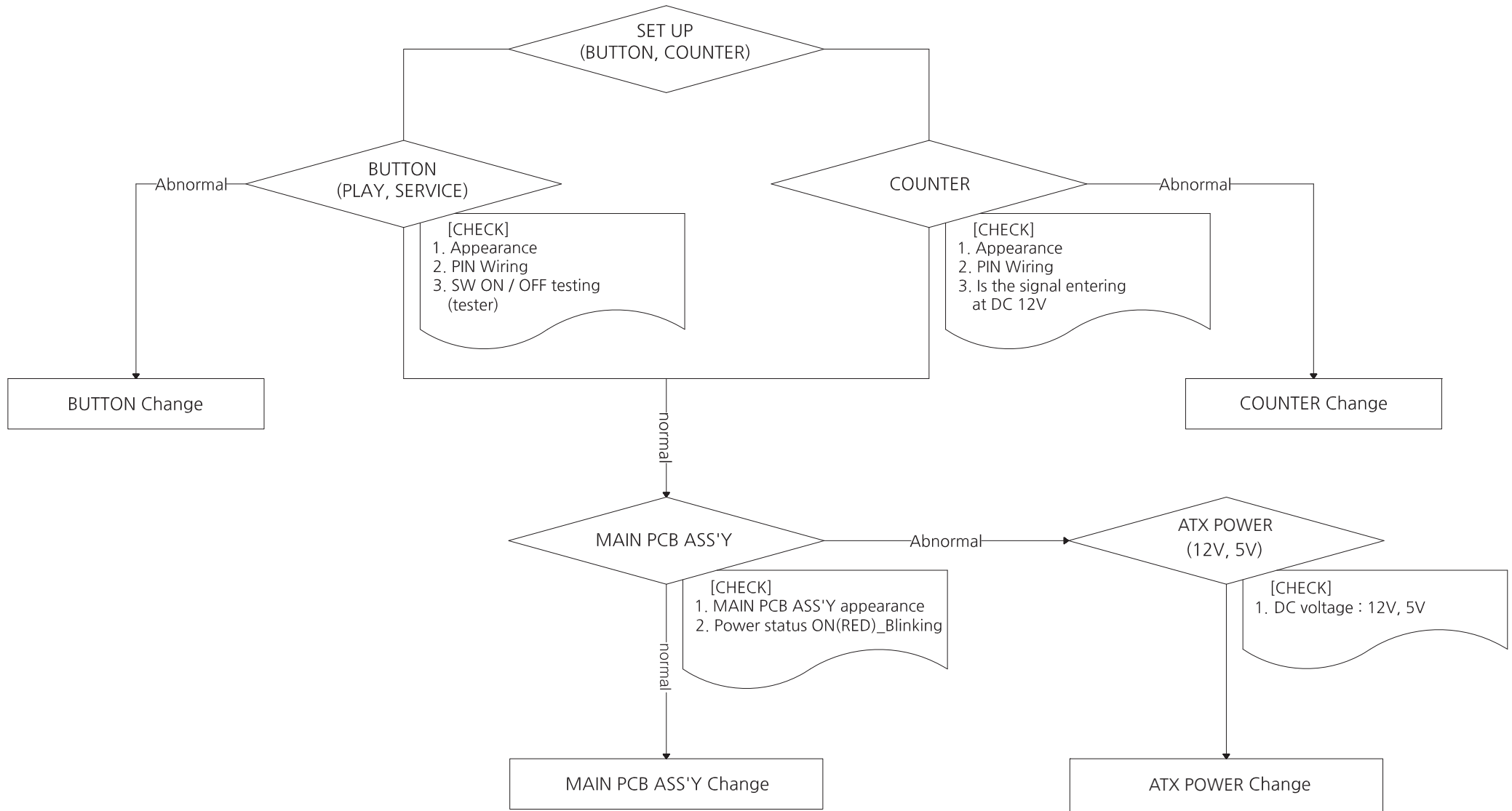

# 5-7. SETUP LCD PCB ERROR

\*Common: Check the input voltage, check wiring

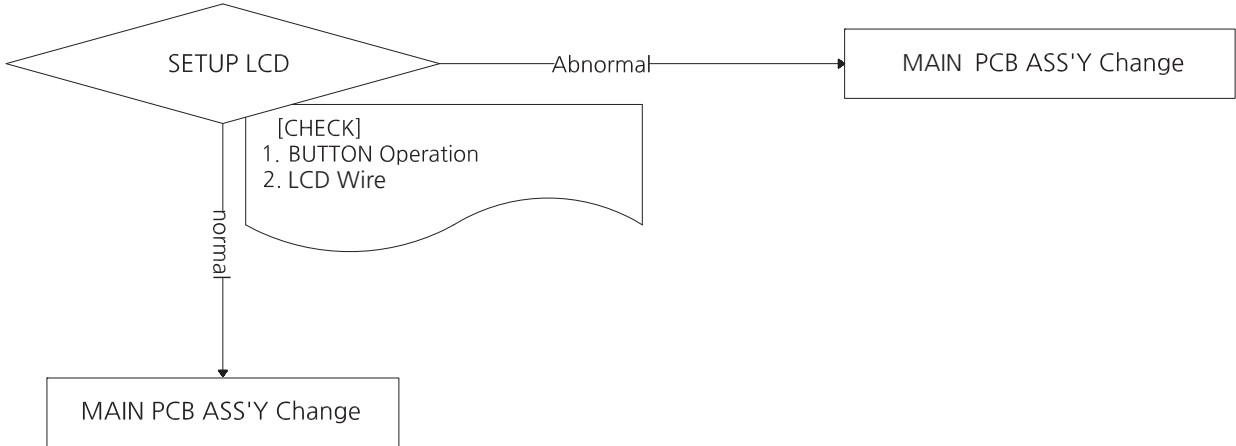



# 5-8. UPPER SIDE LIGHT PCB & CREDIT FND, TIME FND ERROR

\*Common: Check the input voltage, check wiring

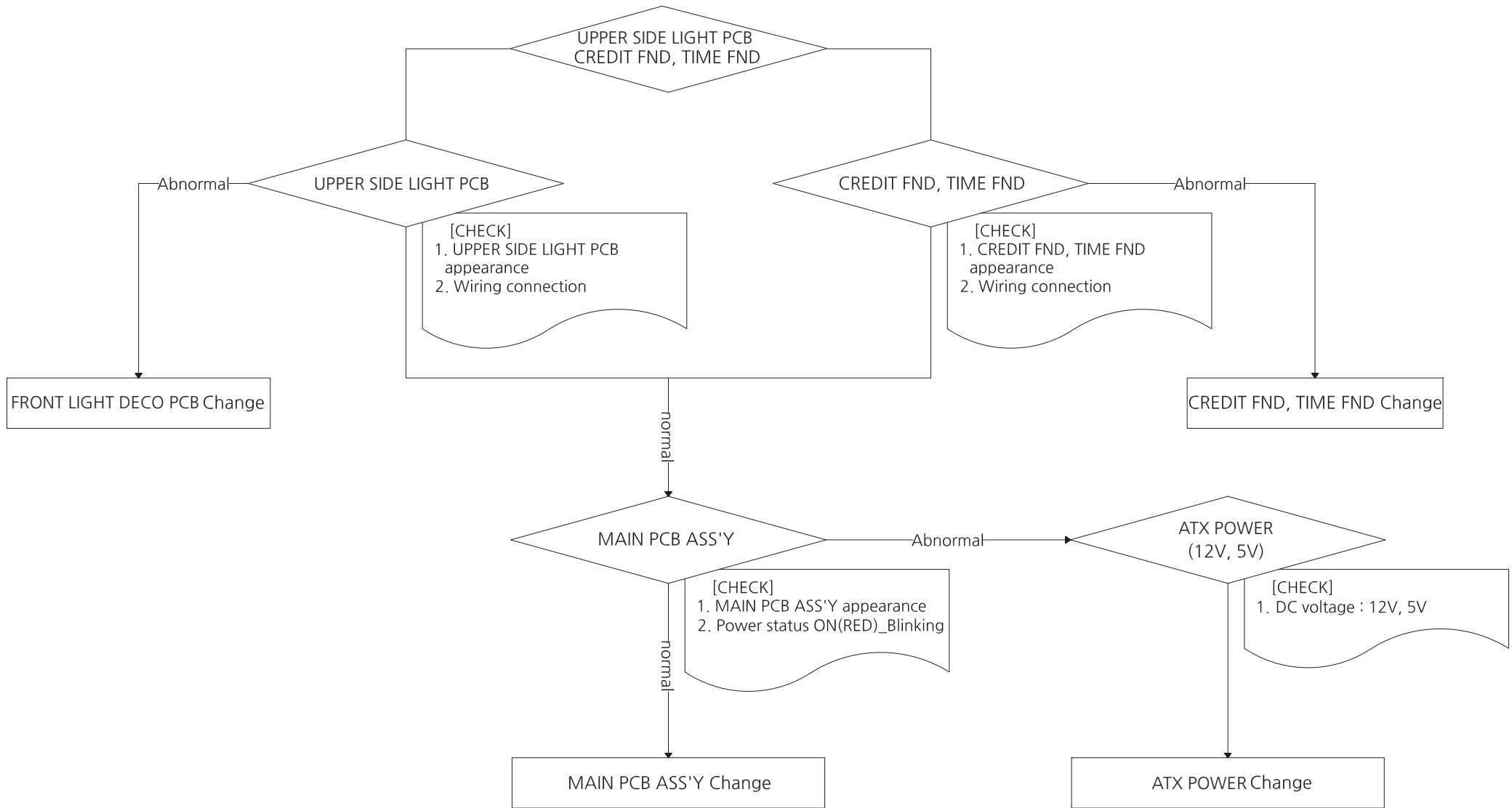

# 6. EXPLODED VIEW

## 6-1. MAIN CABINET PART

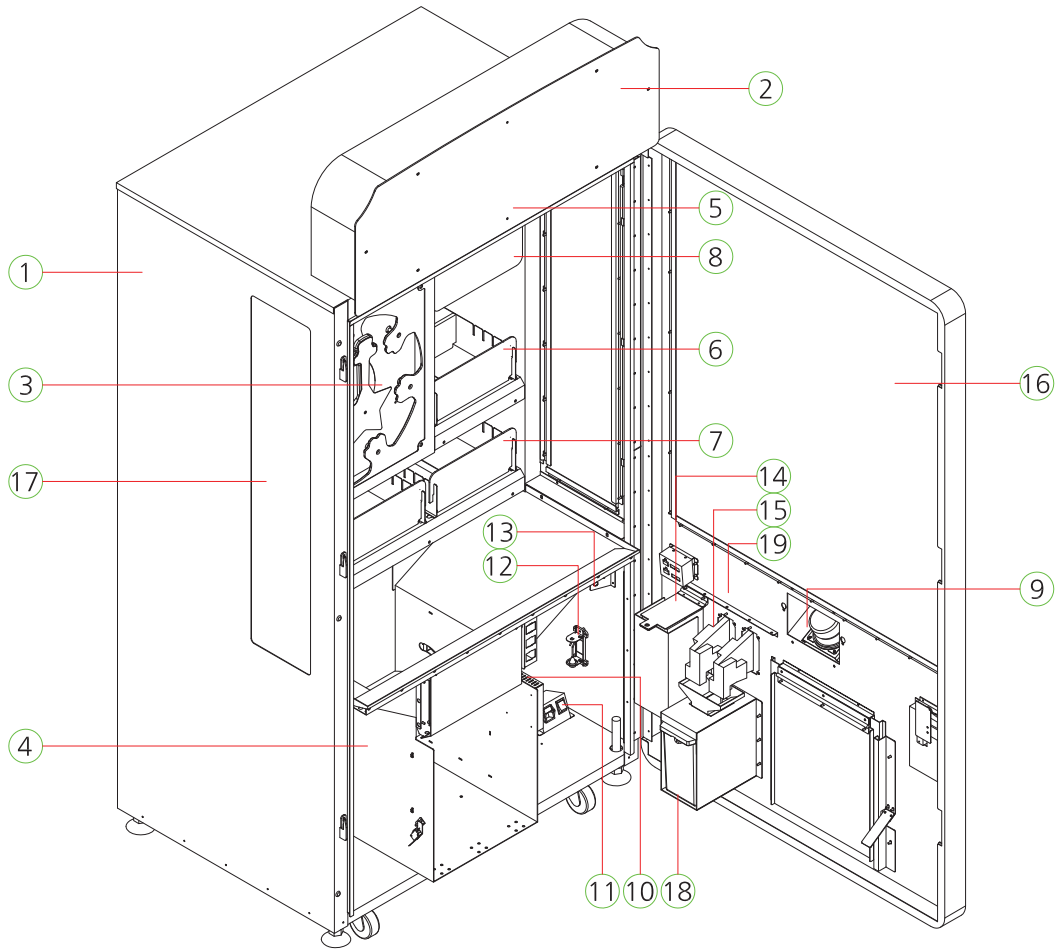

NO.	PART NAME	SPEC.	QUANTITY	CODE NO.
1	MAIN CABINET PART	-	1	-
2	BILLBOARD PART	-	1	-
3	TARGET DISPLAY PART	-	1	-
4	PRIZE GUIDE PART	-	1	-
5	PRIZE DISPENSER PART_TOP	-	1	-
6	PRIZE DISPENSER PART_MIDDLE	-	1	-
7	PRIZE DISPENSER PART_BOTTOM	-	1	-
8	PRIZE DISPENSER LOGO ACRYL	ACRYL-3.0t	1	-
9	BUTTON FRAME PART	-	1	-
10	SMPS PANEL PART	-	1	-
11	COUNTER BKT PART	-	1	-
12	TILT CHECK PART	-	1	-
13	GSM MODEM PART	-	1	-
14	BILL ACCEPT	-	1	-
15	COIN SELECTOR	TW-333	2	MZZZ0COS045
16	FRONT DOOR GLASS	GLASS-8.0t	1	MSHS0GLA002
17	SIDE GLASS	GLASS-8.0t	2	MSHS0GLA001
18	COIN BOX	200*198*107 BLACK	1	MDRE0PLA007
19	CARD READER CONNECTOR PCB ASS'Y	-	1	-

## 6-2. BILLBOARD PART

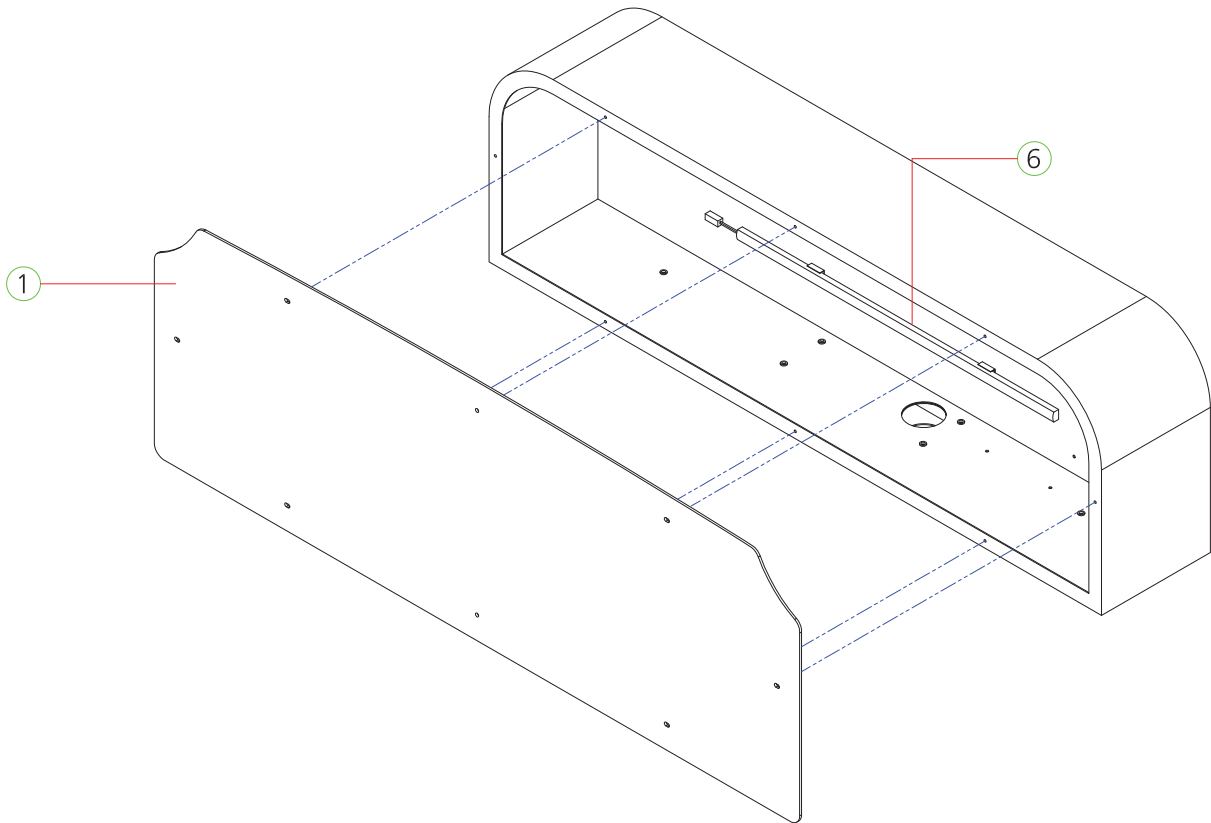

NO.	PART NAME	SPEC.	QUANTITY	CODE NO.
1	BILLBOARD FRAME COVER ACRYL	ACRYL-3.0t	1	MSS20ACR002
2	LED STICK BAR ASS'Y	460mm	1	AZZZ0PCB124

### 6-3. TARGET DISPLAY PART

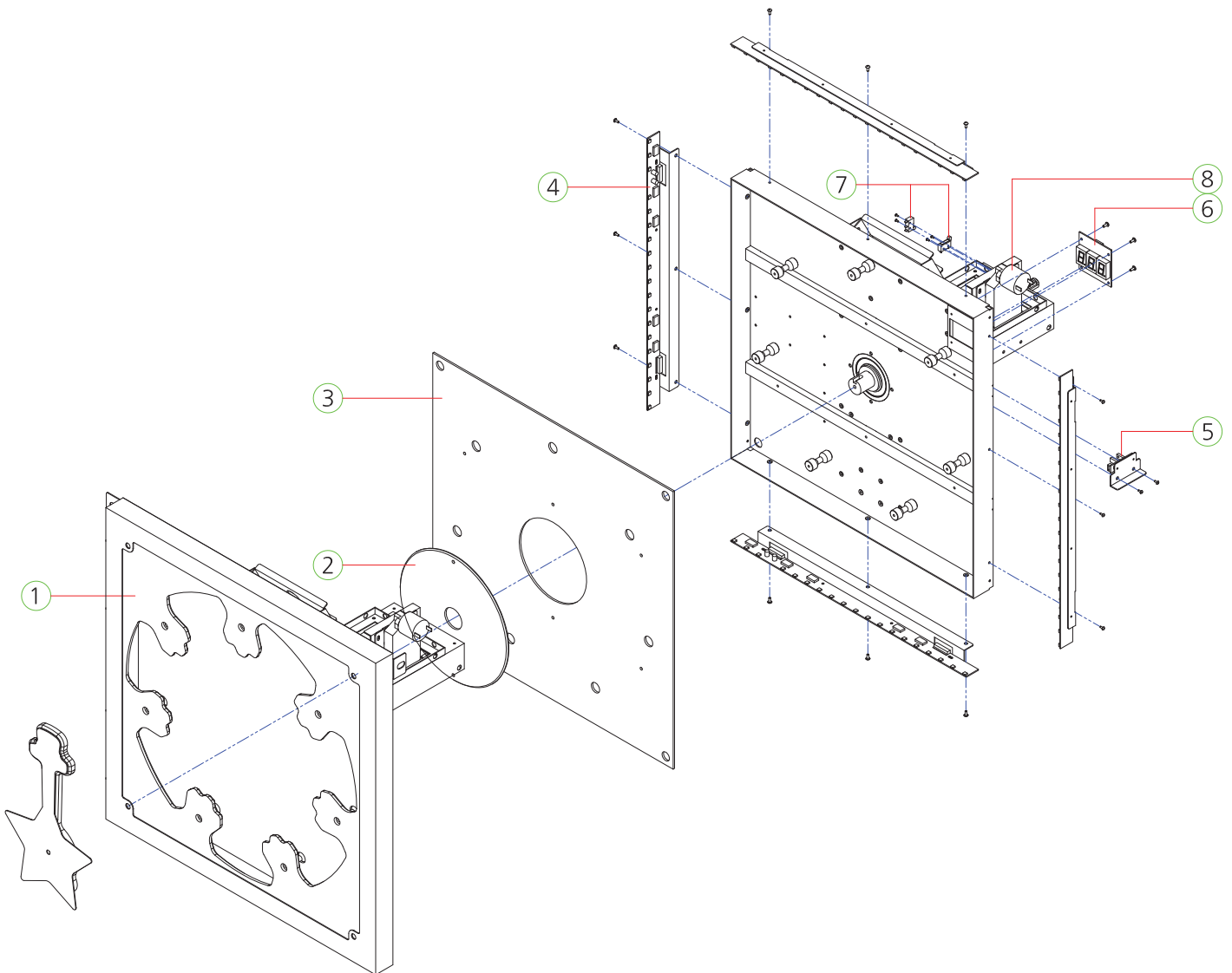

NO.	PART NAME	SPEC.	QUANTITY	CODE NO.
1	TARGET DISPLAY ACRYL	ACRYL-8.0t	1	MSS20ACR001
2	TARGET BASE ACRYL-B	ACRYL-3.0t	1	MSHS0ACR012
3	TARGET BASE ACRYL-A	ACRYL-3.0t	1	MSHS0ACR011
4	TARGET ACRYL SIDE LED ASS'Y	-	4	ASHS0PCB001
5	PHOTO INT-1 PCB ASS'Y	-	1	ACIR0PCB011
6	FND PCB ASS'Y	-	1	ASUS0PCB004
7	MICRO SWITCH	GSMS5_41TL	2	MELE0MIC003
8	MOTOR	4S56Q-08576S	1	MZZZ0MOT064

## 6-4. PRIZE GUIDE PART

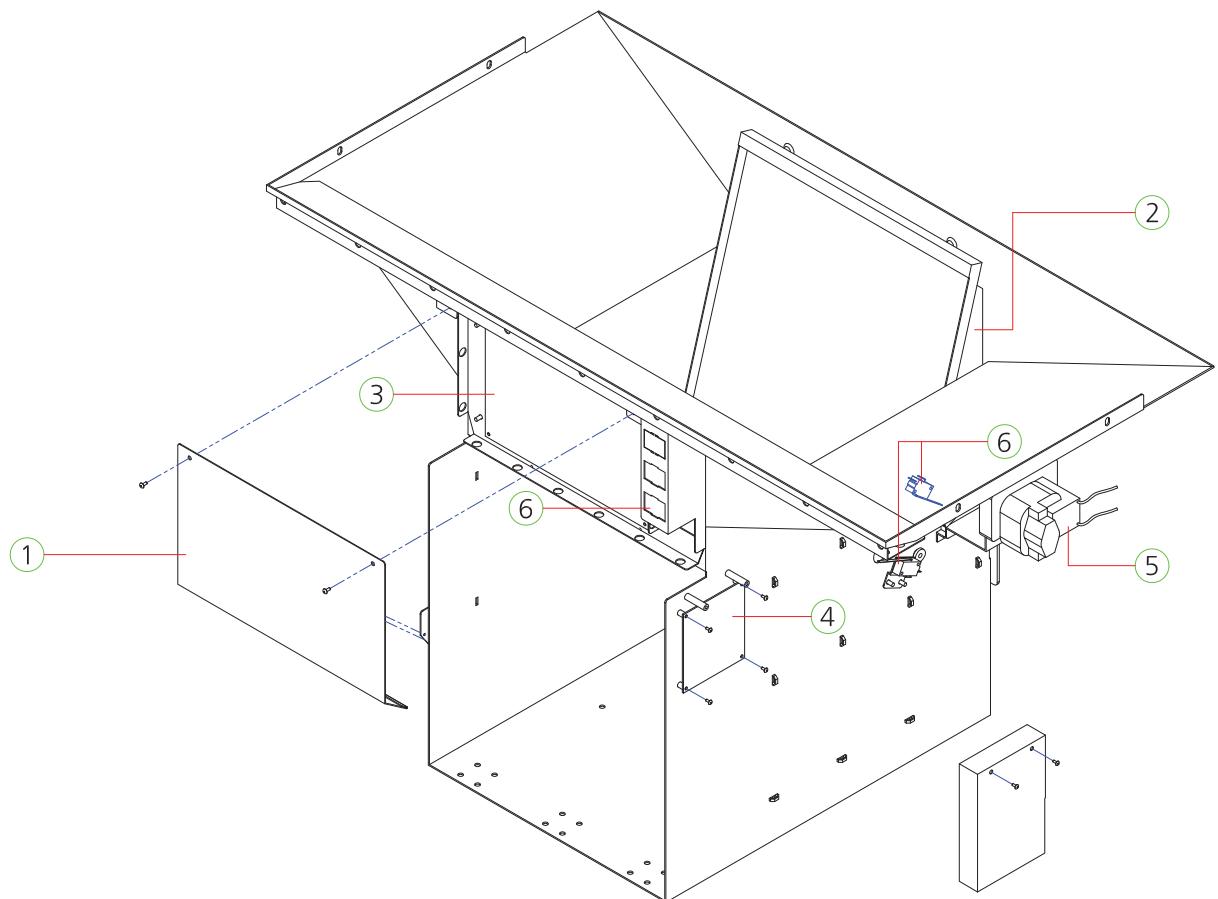

NO.	PART NAME	SPEC.	QUANTITY	CODE NO.
1	MAIN BOARD PC COVER	PC-1.0t	1	MSHS0ACR005
2	HOW TO PLAY ACRYL	ACRYL-3.0t	1	MSHS0ACR009
3	MAIN PCB ASS'Y WITH CPU_SOUND	AIO2 I_S CUBE,SHS,SAFE	1	AZZZ0PCB245
4	AC MOTOR IO PCB ASS'Y	-	1	AICU0PCB007
5	AC MOTOR	KAE-6140A1	1	MZZZ0MOT070
6	MICRO SWITCH	GSM-V1631A1	1	MELE0MIC022

## 6-5. PRIZE DISPENSER PART\_TOP

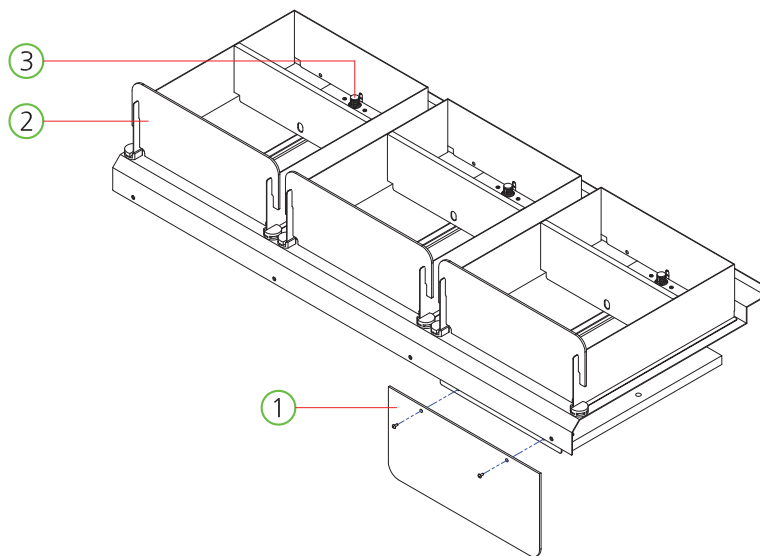

NO.	PART NAME	SPEC.	QUANTITY	CODE NO.
1	PRIZE DISPENSER LOGO ACRYL	ACRYL-3.0t	1	MSHSOACR010
2	PRIZE DISPENSER PUSH ACRYL-A	ACRYL-3.0t	3	MSHSOACR007
3	PRIZE DISPENSER PART	-	3	-

## 6-6. PRIZE DISPENSER PART\_MIDDLE

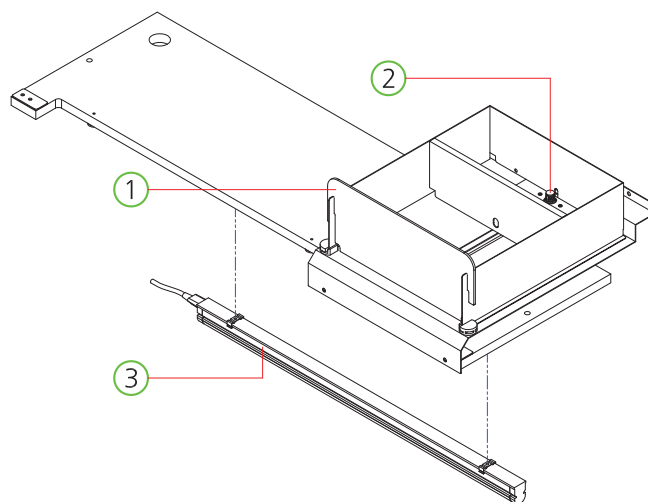

NO.	PART NAME	SPEC.	QUANTITY	CODE NO.
1	PRIZE DISPENSER PUSH ACRYL-A	ACRYL-3.0t	1	MSHSOACR007
2	PRIZE DISPENSER PART	-	1	-
3	LED BAR ASS'Y	-	1	-

## 6-7. PRIZE DISPENSER PART\_BOTTOM

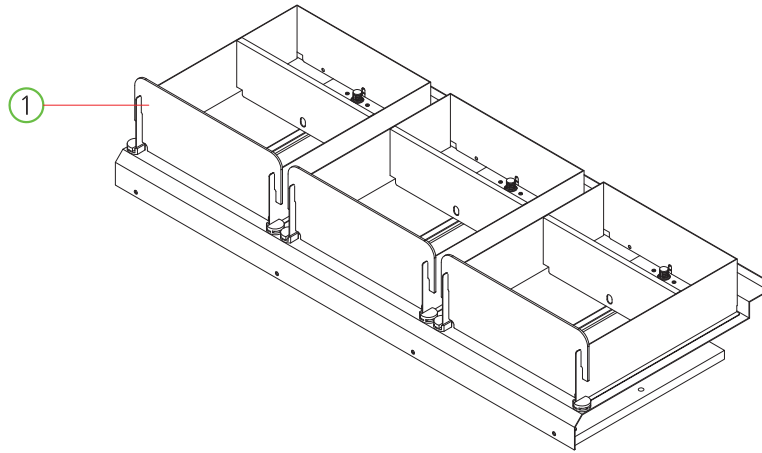

NO.	PART NAME	SPEC.	QUANTITY	CODE NO.
1	PRIZE DISPENSER PUSH ACRYL-A	ACRYL-3.0t	3	MSHS0ACR007

## 6-8. PRIZE DISPENSER PART

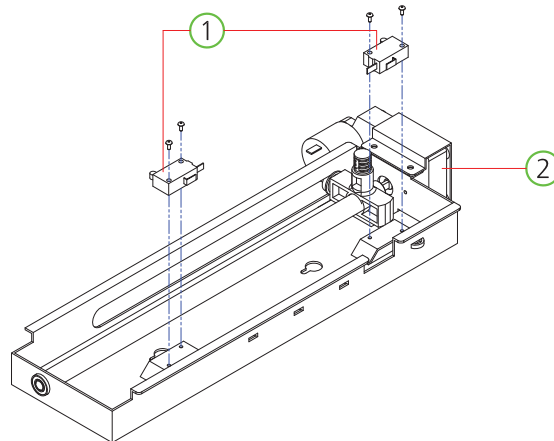

NO.	PART NAME	SPEC.	QUANTITY	CODE NO.
1	MICRO SWITCH	SZM-V165FA63	2	-
2	DC MOTOR	KGE-3429-050	-	MZZZ0MOT082

## 6-9. BUTTOM FRAME PART

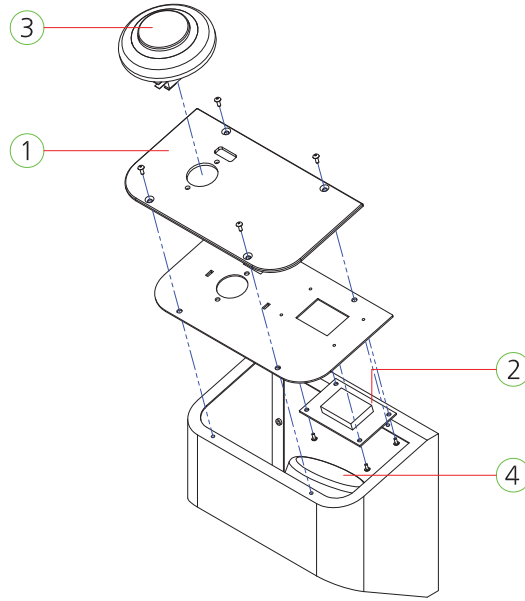

NO.	PART NAME	SPEC.	QUANTITY	CODE NO.
1	BUTTON ACRYL	ACRYL-3.0t	1	MSS20ACR003
2	CREDIT FND PCB ASS'Y	-	1	AWID0PCB004
3	BUTTON ASS'Y	BLC-TNWB-PW-CW-C	1	-
4	SPEAKER	MID4.5"+TW1/2" 8Ω	1	MZZZ0SPE021

## 6-10. SMPS PANEL PART

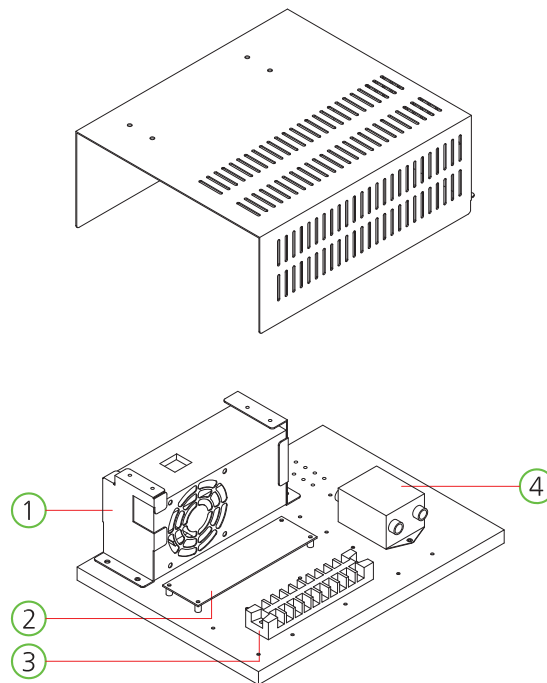

NO.	PART NAME	SPEC.	QUANTITY	CODE NO.
1	ATX POWER SUPPLY	SPC-350_UL POREX	1	MELE0SMP062
2	ATX JOIN PCB ASS'Y	-	1	ASUP0PCB008
3	TERMINAL BLOCK	250V 10P	1	MELE0TEB003
4	NOISE FILTER	ES1-F10	1	MELE0NOI006



## 6-11. AC INPUT PART

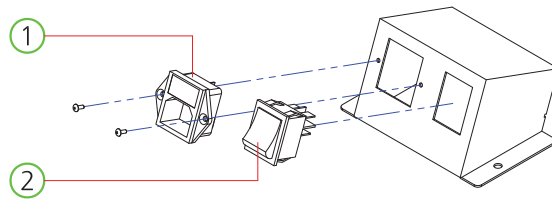

NO.	PART NAME	SPEC.	QUANTITY	CODE NO.
1	AC INPUT	DAC-13H	1	MELE0SWI015
2	ROCKER SWITCH	-	1	-

# 7. WARRANTY ITEM

## 6-1. MAIN CABINET PART

- BILLBOARD PART

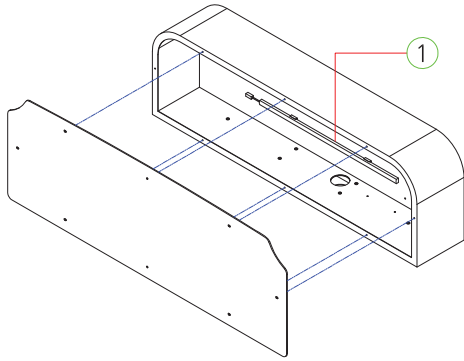

- TARGET DISPLAY PART

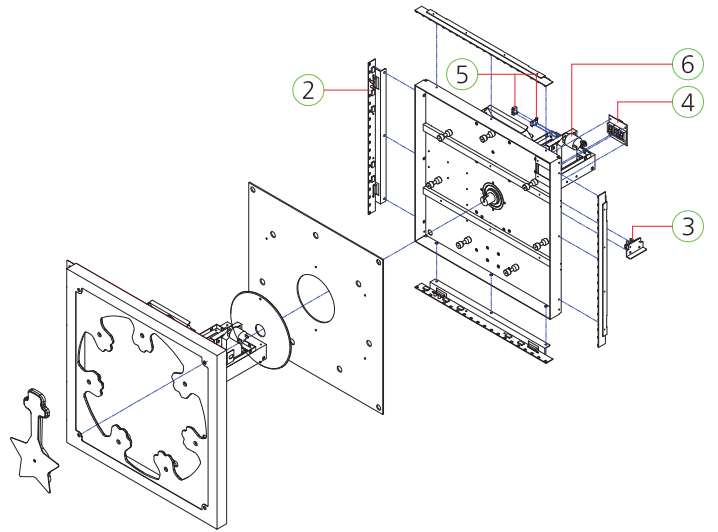

- PRIZE DISPENSER PART

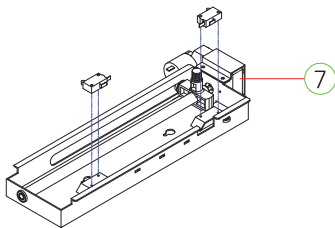

- BUTTON FRAME PART

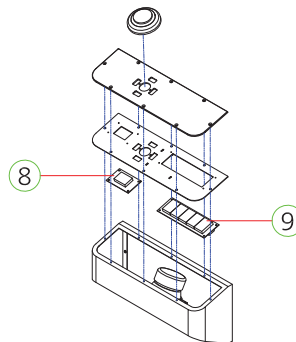

- SMPS PANEL PART

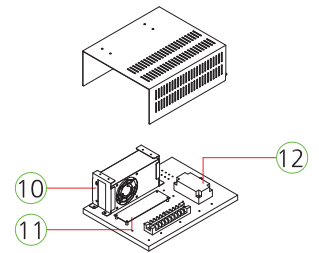

- PRIZE GUIDE PART

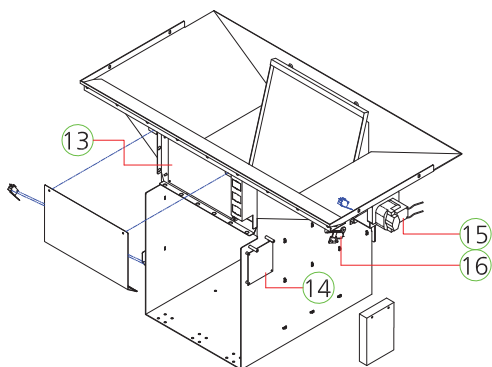

NO.	PIC	PART NAME	SPEC.	QTY	CODE NO.	WARRANTY	
						6 Month	One Year
①	○	LED STICK BAR ASS'Y	460mm	1	AZZZ0PCB124		○
②	○	TARGET ACRYL SIDE LED ASS'Y	-	4	ASHS0PCB001		○
③	○	PHOTO INT-1 PCB ASS'Y	-	1	ACIR0PCB011		○
④	○	FND PCB ASS'Y	-	1	ASUS0PCB004		○
⑤	○	MICRO SWITCH	GSMS5_41TL	2	MELE0MIC003		○
⑥	○	MOTOR	4S56Q-08576S	1	MZZZ0MOT064	○	
⑦	○	MOTOR	KWC-0025-3429G-0004	1	MZZZ0MOT063	○	
⑧	○	CREDIT FND PCB ASS'Y	-	1	AWID0PCB004		○
⑨	○	FND PCB ASS'Y	2941-5(STRAIGHT)	1	AFND0PCB005		○
⑩	○	ATX POWER SUPPLY	FSP300_60GHT_85	1	MELE0SMP099		○
⑪	○	ATX JOIN PCB ASS'Y	-	1	ASUP0PCB008		○
⑫	○	NOISE FILTER	RNS-2010	1	MELE0NOI009		○
⑬	○	MAIN PCB ASS'Y WITH CPU_SOUND	-	1	AZZZ0PCB245		○
⑭	○	AC MOTOR IO PCB ASS'Y	-	1	AICU0PCB007		○
⑮	○	AC MOTOR	KAE-6140A1	1	MZZZ0MOT070		○
⑯	○	MICRO SWITCH	GSM-V1631A1	1	MELE0MIC022		○

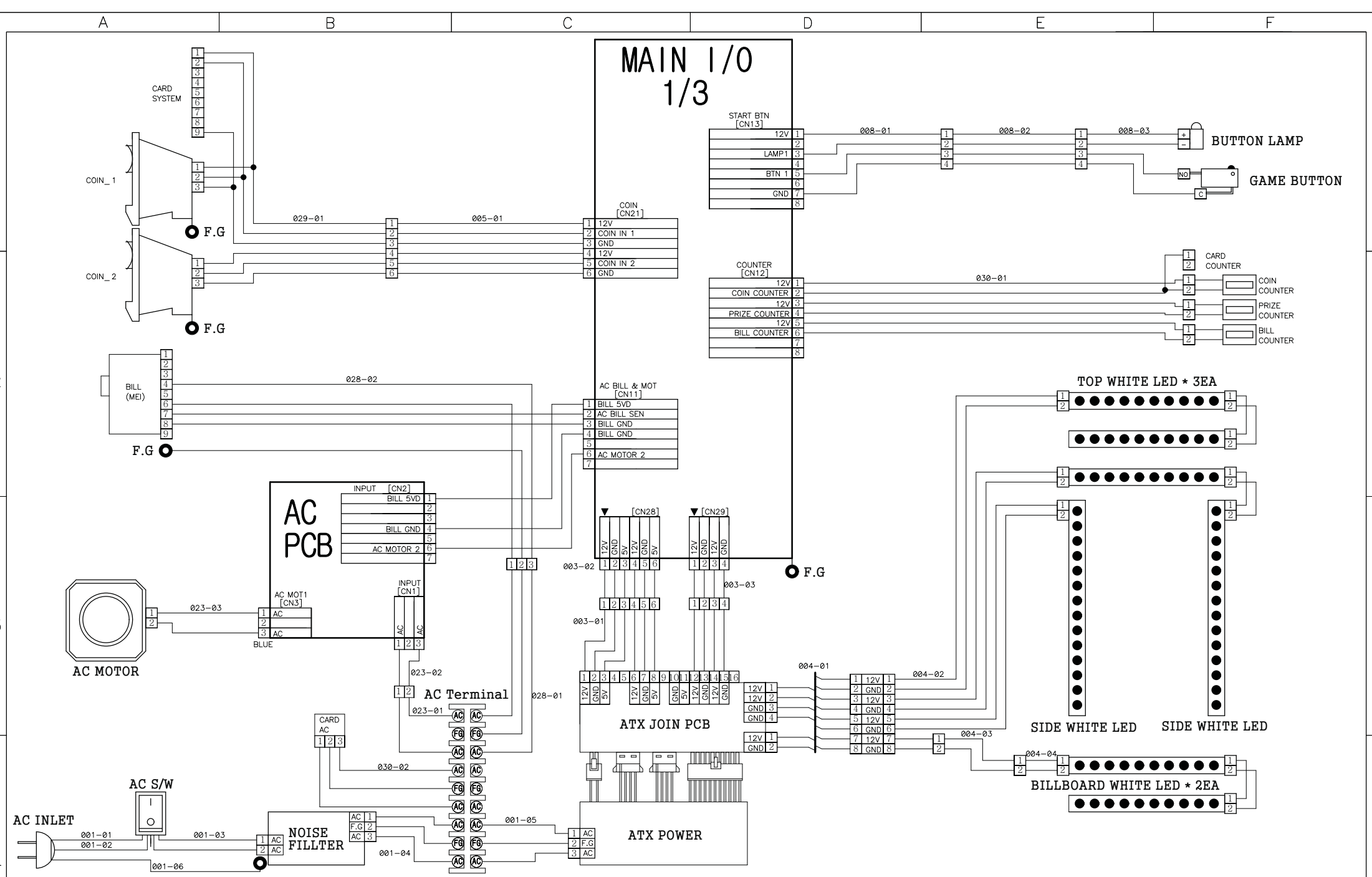

REPRODUCTION, DISTRIBUTION AND UTILIZATION OF THIS DOCUMENT AS WELL AS COMMUNICATION OF ITS CONTENTS TO OTHERS WITHOUT EXPRESS AUTHORIZATION PROHIBITED. OFFENDERS WILL BE HELD LIABLE FOR THE PAYMENT OF DAMAGES. ALL RIGHT RESERVED. COPYRIGHT (c) ANDAMIRO

(복제, 배포 및 사용은 물론, 명시적 허가 없이는 라인에게 내용을 전달할 수 없으며 위반자는 손해 배상 책임을 집니다.)

DEPARTMENT	DRAWN BY	CHECKED BY	APPROVED BY	ITEM	SUPER STAR2 - INT
H/W	Y.Y.CHO			PAGE	2023.05.31
ANDAMIRO				DATE	1 PAGE

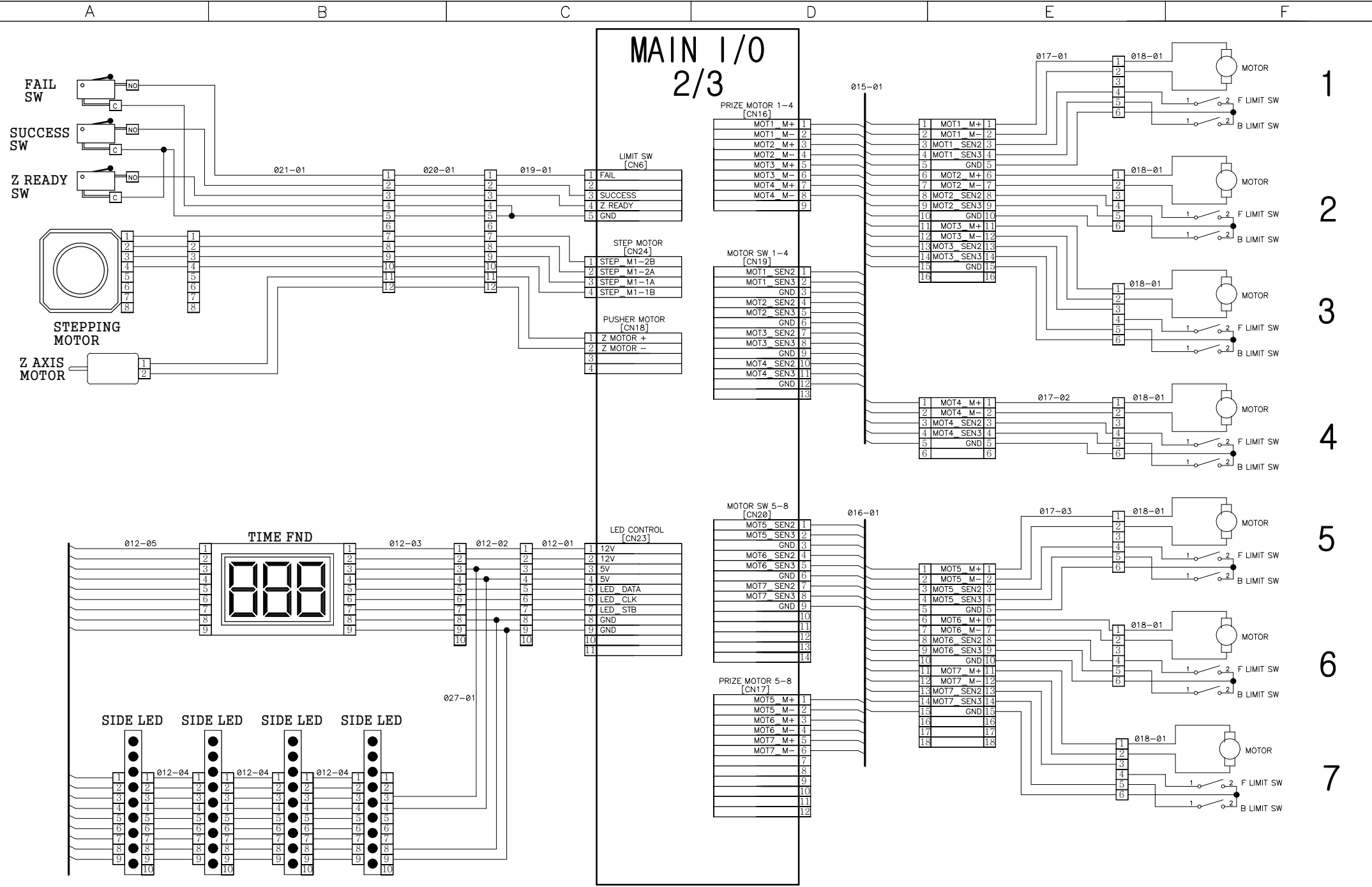

REPRODUCTION, DISTRIBUTION AND UTILIZATION OF THIS DOCUMENT AS WELL AS COMMUNICATION OF ITS CONTENTS TO OTHERS WITHOUT EXPRESS AUTHORIZATION PROHIBITED. OFFENDERS WILL BE HELD LIABLE FOR THE PAYMENT OF DAMAGES. ALL RIGHT RESERVED. COPYRIGHT (c) ANDAMIRO

(복제, 배포 및 사용은 물론, 명시적 허가 없이는 라인에게 내용을 전달할 수 없으며 위반자는 손해 배상 책임을 집니다.)

DEPARTMENT	DRAWN BY	CHECKED BY	APPROVED BY	ITEM	SUPER STAR2 - INT
H/W	Y.Y.CHO			PAGE	2023.05.31
ANDAMIRO				DATE	2 PAGE

# MAIN 1/0 3/3

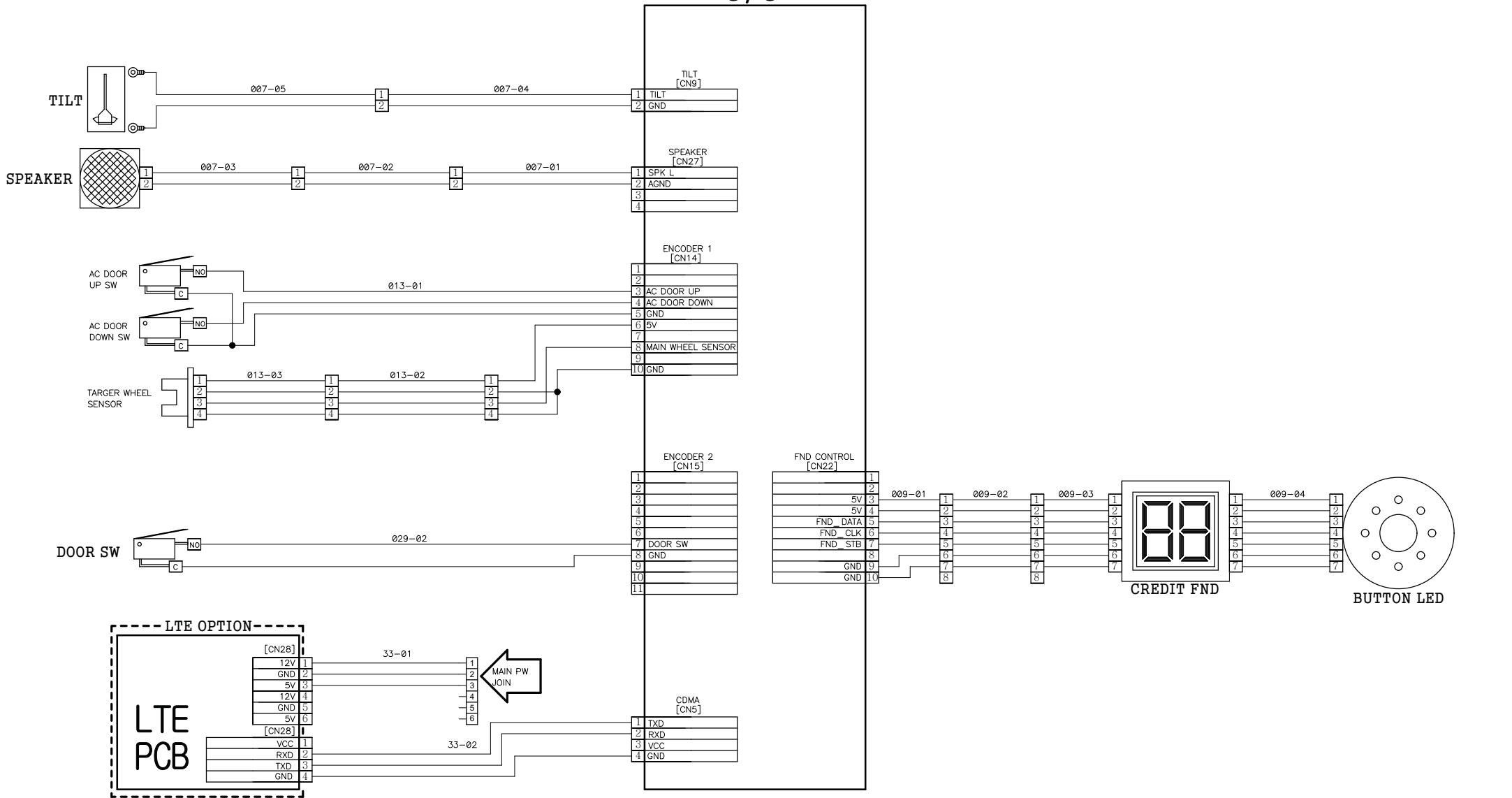

REPRODUCTION, DISTRIBUTION AND UTILIZATION OF THIS DOCUMENT AS WELL AS COMMUNICATION OF ITS CONTENTS TO OTHERS WITHOUT EXPRESS AUTHORIZATION PROHIBITED. OFFENDERS WILL BE HELD LIABLE FOR THE PAYMENT OF DAMAGES. ALL RIGHT RESERVED. COPYRIGHT (c) ANDAMIRO

(복제, 배포 및 사용은 물론, 명시적 허가 없이는 타인에게 내용을 전달할 수 없으며 위반자는 손해 배상 책임을 집니다.)

DEPARTMENT	DRAWN BY	CHECKED BY	APPROVED BY	ITEM	SUPER STAR2 - INT
H/W	Y.Y.CHO			PAGE	2023.05.31
ANDAMIRO				DATE	3 PAGE



## **ANDAMIRO WARRANTY POLICY**



Andamiro warrants to the original purchaser that all of its products will be free from defects in material and workmanship.

**Andamiro warrants the parts from date of shipment as follows.**

- **One Year Limited Warranty : Electronic Boards**
- **6 Month Limited Warranty : Moving Parts**

For any key components within the warranty period, Andamiro will repair or replace defective components free of charge.

When placing a warranty request, the customer is requested to furnish the following information:

1. Name of the game.
2. Serial Number of the game.
3. A Detailed Description of the defect/s experienced.

This warranty does not apply to the defects caused due to misuse or abuse of the product.

Any alterations made to game or game parts will void this warranty.

For warranty details on our product range please visit our website, [www.andamiro.com](http://www.andamiro.com).

ANDAMIRO CO., LTD.  
[www.andamiro.com](http://www.andamiro.com)





---

**ANDAMIRO CO., LTD.**

TEL : 82-31-909-2123~5

**[ADDRESS OFFICE]** 704-1 Techno Town, 138, Ilsan-ro, Ilsandong-gu, Goyang-si,  
Gyeonggi-do, Republic of Korea 10442

**[FACTORY]** 72 Nochemgil, Ilsan-donggu Goyang-si, Gyonggi-do, 410-834 korea

**USA BRANCH**

ANDAMIRO USA CORP.

TEL : 1-310-767-5800

**[ADDRESS USA]** 2222 Century Cir, Irving TX 75062 U.S.A

Homepage <http://www.andamiro.com/>