

HOW TO INSTALL

* BILLBOARD ASSEMBLY

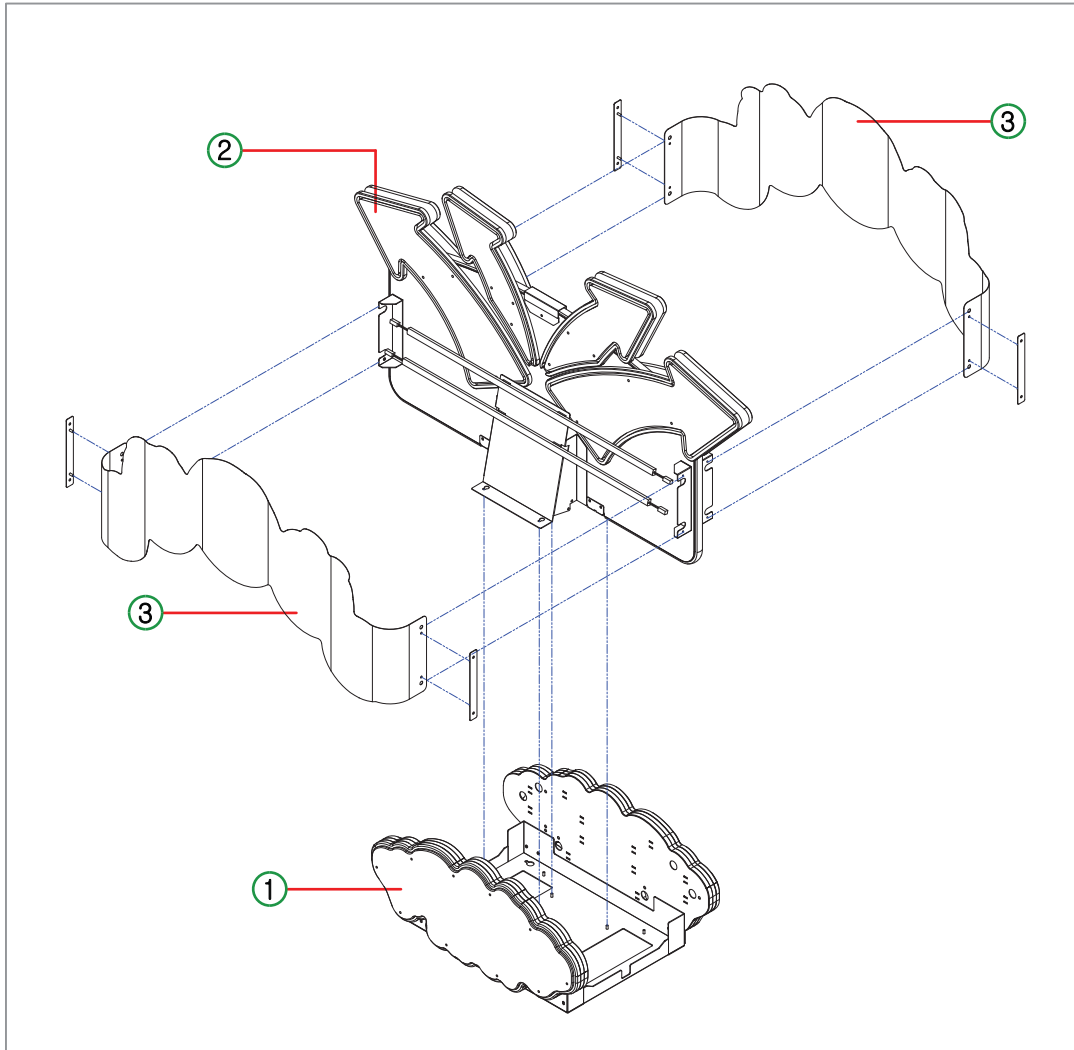

| NO | PROCESS | ITEM | Q'TY | BOLT | SPEC | Q'TY |
|----|----------|--------------------------------------|------|-------------|-------|------|
| 1 | | BILLBOARD BASE ASS'Y | 1 | | | |
| 2 | ASSEMBLE | BILLBOARD BACKGROUND ASS'Y | 1 | FLANGE NUT | M4 | 4 |
| 3 | ASSEMBLE | BILLBOARD FRONT FOMAX MIDDLE FIX BKT | 2 | SCREW TH NI | M4x8L | 8 |
| | | | | FLANGE NUT | M4 | 8 |

* FULL ASSEMBLY

* Connector location

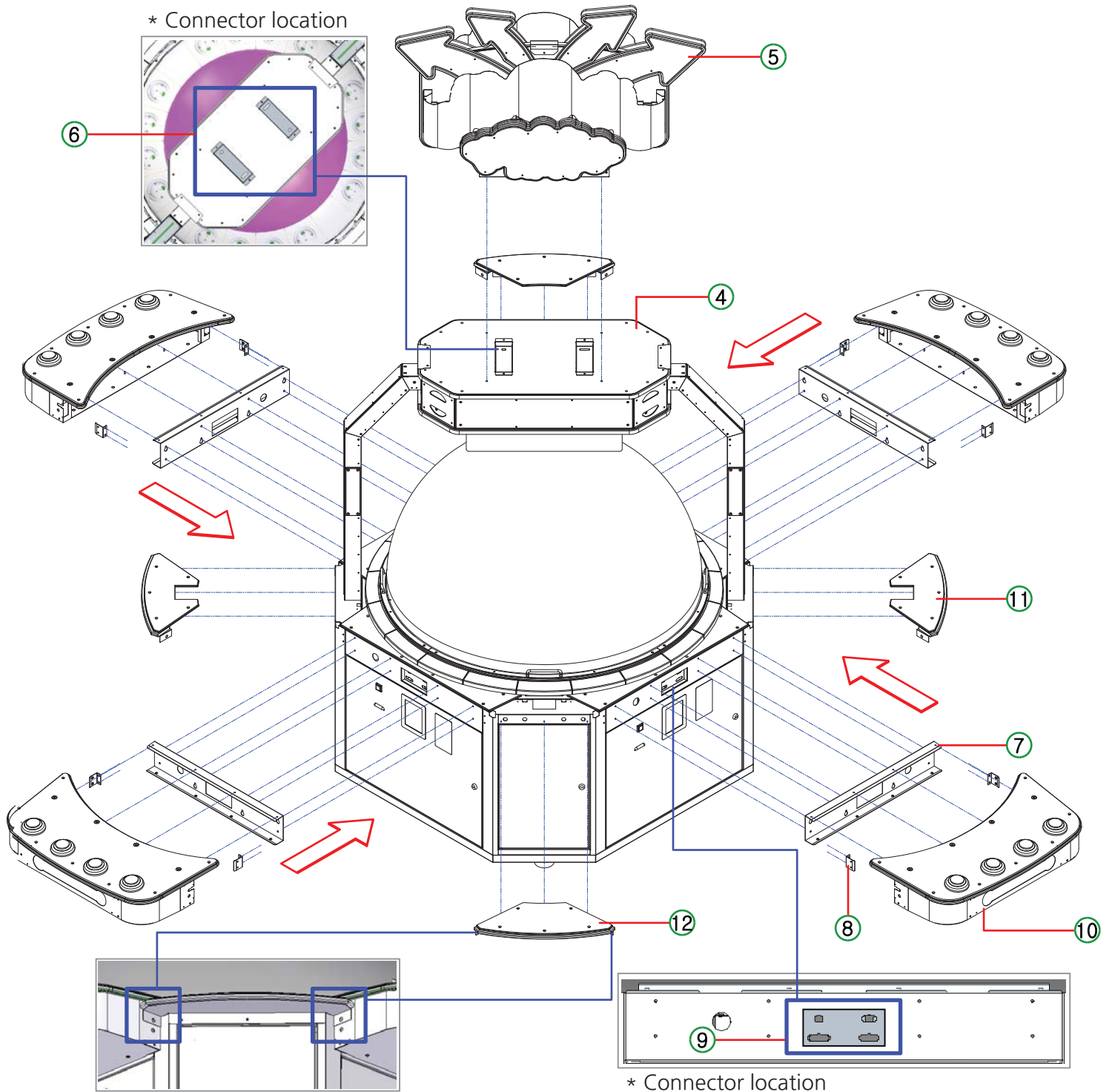

* Connector location

| NO | PROCESS | ITEM | Q'TY | BOLT | SPEC | Q'TY |
|----|------------|------------------------------|------|---------------------------------------|---------------------------|-------------|
| 4 | ASSEMBLE | CABINET ASS'Y | 1 | | | |
| 5 | ASSEMBLE | BILLBOARD ASS'Y | 1 | SCREW FH NI | M5x30L | 4 |
| 6 | CONNECTION | BILLBOARD CONNECTOR | | | | |
| 7 | ASSEMBLE | BUTTON TABLE FIX BKT | 4 | SEMS NI | M6x16L | 8 |
| 8 | ASSEMBLE | BUTTON TABLE FIX SUPPORT BKT | 8 | SEMS NI | M6x16L | 16 |
| 9 | CONNECTION | BUTTON TABLE CONNECTOR | | | | |
| 10 | ASSEMBLE | BUTTON TABLE ASS'Y [1~4P] | 4 | SCREW FH NI SEMS NI | M6x30L M6x16L | 16 16 |
| 11 | ASSEMBLE | CORNER TABLE PART-A | 2 | SCREW TH NI SCREW FH NI SEMS NI | M4x8L M4x12L M6x16L | 6 4 4 |
| 12 | ASSEMBLE | CORNER TABLE PART-B | 2 | Same as NO. 11 | | |

*Reuse of fixing bolts