

# SERVICE MANUAL



[ IMPORTANT ]

- ▶ Please read the manual carefully and keep it in mind before using this machine
- ▶ Put this manual within touch of your reference in anytime.

ISSUE DATE:Jan. 24, 2025

PRODUCT INFO	PART INFO	SUPPORT INFO	NEW PRODUCT INFO

※ QR(SUPPROT) - Leaflets, manuals, solution(error code,trouble shooting document, watch&solve)

# PRECAUTIONS FOR USE

The following safety precautions are given throughout this manual. They must be strictly followed to protect those who install, use or maintain this product as well as to protect players, visitors and property.

## For safety reasons.

- The following suggestions should be adhered to:



Disregarding could result in serious injury.



Disregarding could result in injury or product damage.

- The following graphic suggestions describe the types of precautions to be followed.



Indicates a care should be taken.



Forbidden.



Indicates a matter which must be performed.

- **Precautions to be followed:**

**Certain procedures require a qualified in-shop maintenance person or industry specialist.**

**For such instructions, a qualified person must take care of the jobs.**

- Otherwise an electric shock, machine trouble or a serious accident may result.
- Replacing the machine parts, inspecting and maintaining the machines and troubleshooting must be assigned only to a qualified in-shop maintenance person or industry specialist. This booklet gives instructions that hazardous jobs in particular must be handled by an industry specialist. Qualified in-shop maintenance person and industry specialist are defined as follows.

### **Qualified in-shop maintenance person**

- A service staff shall have experience in operations of game machines. The staff shall be responsible for assembly, installation, inspection and maintenance of the machine.

### **Industry specialist**

- An industry specialist must be engaged in designing, manufacturing, inspecting and servicing amusement machines. He or she must have an education in electrical, electronic and mechanical engineering and routinely maintain and repair amusement machines.

# PRECAUTIONS FOR USE

## WARNING

**Be sure to consult an industry specialist when setting up, moving or transporting this product.**

- This product should not be set up, moved or transported by any one other than an industry specialist.
- When installing this product, set the 4 leg levelers evenly on the floor and make sure that the product is installed stably in a horizontal position. Unstable installation may result in injury or accident.
- When installing this product, do not apply undue force on movable parts. Otherwise, injury and accident may result, or the product may be damaged.

**The machine for indoor usage only does not install outside.**



**Do not set the game machine up near emergency exits.**



**Protect the game machine from:**

- Rain or moisture.
- Direct sunlight.
- Direct heat from air-conditioning and heating equipment, etc..
- Hazardous flammable substances.
- Otherwise an accident or malfunction may result.



**Do not place containers holding chemicals or water on or near the game machine.**



**Do not place objects near the ventilating holes.**



**Do not bend the power cord by force or place heavy objects on it.**



**Never plug or unplug the power cord with wet hands.**



**Never unplug the game machine by pulling the power cord.**



## CAUTION

**Be sure to use indoor wiring within the specified voltage requirements. For extension cord, use the specified rating or more.**

**Be sure to use the attached power cord.**

**Never plug more than one cord at a time into the electrical receptacle.**



**Do not lay the power cord where people walk through.**



**Be sure to ground this product.**



**Do not exert excessive force when moving the machine.**



**For proper ventilation, keep the game machine 100mm(4") away from the walls.**

**Do not alter the system related dipswitch settings.**

# PRECAUTIONS FOR USE

## WARNING

**If there is any abnormality such as smoke, bad smell or abnormal noise being emitted from the machine, immediately turn OFF the main power switch and unplug the power cord from the receptacle to stop operating it.** 

- Using the machine in abnormal conditions could result in fire or accidents.

### In case of abnormality

1. Turn OFF the main power switch.
2. Unplug the power cord from the receptacle.
3. Contact your nearest dealer.

**Do not leave the power cord plugged in improperly or covered with dust.** 

- Doing so could result the power cord periodically.

## CAUTION

**Do not use this product anywhere other than industrial areas.** 

- Using in a residential area or an area next to a residential area could affect signal reception of radios, television sets, telephones and etc..
- Do not give shock the surface of glass products.

- Please do not play this game if
  - When you do drinking;
  - When your physical condition is not normal;
  - When you are in pregnancy;
  - When you have on a pulse controller;
  - When you have recently experienced a cramp or fainting away while watching TV.
- Avoid excessive force/shock while playing/moving the game.
- While do games, pay attention to surrounding.

**Do not plug or unplug the power cord with wet hands.** 

**In handling the power cord, follow the instructions below.** 

- |   |  |
|---|--|
| • Do not damage the power cord.           | • Do not modify the power cord.            |
| • Do not bend the power cord excessively. | • Do not twist the power cord.             |
| • Do not heat the power cord.             | • Do not pull the power cord.              |
| • Do not bind the power cord.             | • Do not stand on the power cord.          |
| • Do not sandwich the power cord.         | • Do not drive a nail into the power cord. |

**If the power cord or power plug becomes damaged, stop using the machine immediately and ask your nearest dealer to replace the parts.**

**\* Electromagnetic wave may cause unexpected noise from speaker.**

# PRECAUTIONS FOR USE

## ⚠ WARNING

Be sure to turn OFF the main power switch and unplug the power cord from the receptacle before inspecting or cleaning the machine.



When replacing parts, be sure to use parts of the correct specifications. Never use parts other than the specified ones.



Opening inside the machine shall be done by machine specialist only as high electric current is being sent inside. For game machine with monitor, a care should be taken while opening its back door. If not, a damage to the inside parts or the monitor may occur.



If the sub power switch of the service panel is turned OFF without turning OFF the main power switch of the power supply unit, some parts in the units remain live. When opening the back door, be sure to turn OFF the main power switch and unplug the power cord from the receptacle.



Strictly refrain from disassembly and repair of parts which are not indicated in this manual, as well as settings and remodeling.



To clean the game machine, wipe it with a soft cloth dampened in a neutral detergent.

- Using thinner or other organic solvent or alcohol may decompose the material.
- Electrical shock or equipment failure could be caused by water entering the inside of the machine.

## ⚠ CAUTION

Components in the game are sensitive to vibrations and impact. Care should be used when moving and transporting the game machine.



Be sure not to let the machine tip over.

Before moving the machine, be sure to turn OFF the main power switch, unplug the power cord from the receptacle and remove the power cord from the machine.



Before moving take the machine, off the levelers and move it on the casters.

Avoid excessive force while moving the machine.

.....

## PRECAUTIONS IN HANDLING

- When setting up, inspecting, maintaining, moving or transporting this product, follow the procedures and instructions set forth in this manual and perform such work safely.
- Do not set up, handle, inspect, maintain, move or transport this product under conditions equivalent to the condition of "WARNING" or "CAUTION" specified in this manual.
- If a new owner is to have this product as a result of transfer, and etc., be sure to give this manual to the new owner.

# PRÉCAUTION D'EMPLOI

Les consignes de sécurité suivantes sont données dans ce manuel. Elles doivent être strictement suivies pour protéger ceux qui les installent. Utiliser ou entretenir ce produit pour la sécurité des utilisateurs, des visiteurs et des biens.

Pour des raisons de sécurité.

- **Les suggestions suivantes doivent être respectées:**

## **ATTENTION**

Le non-respect peut entraîner des blessures graves.

## **PRUDENCE**

Le non-respect peut entraîner des blessures ou des dommages au produit.

- **Les suggestions graphiques suivantes décrivent les types de précautions à prendre.**



Indique qu'attention est requise.



Interdit.



Indique que quelque chose doit être effectuée.

- **Les précautions à prendre :**

**Certaines procédures exigent une personne de maintenance qualifiée en atelier ou un spécialiste de l'industrie. Pour ces instructions, une personne qualifiée doit prendre soin des travaux.**

- Sinon, un choc électrique, un dysfonctionnement de la machine, ou un accident grave peut en résulter.
- Remplacement des pièces de machines, l'inspection et la maintenance des machines, et le dépannage doit être attribué qu'à une personne de maintenance qualifiée en atelier ou spécialiste de l'industrie. Cette brochure donne des instructions que les emplois dangereux, en particulier, doivent être traités par un spécialiste de l'industrie. La personne de maintenance qualifiée en atelier et le spécialiste de l'industrie sont définis comme suit.

### **La personne de maintenance qualifiée en atelier**

- Un personnel de service doit avoir de l'expérience dans les opérations de machines de jeux. Le personnel est responsable pour l'assemblage, l'installation, l'inspection et l'entretien de la machine.

### **Le spécialiste de l'industrie**

- Un spécialiste de l'industrie doit être engagé dans la conception, la fabrication, l'inspection et l'entretien des appareils d'amusement.  
Il ou elle doit avoir une formation en génie électrique, électronique et mécanique, et de maintenir régulièrement et de réparer les appareils d'amusement.

# PRÉCAUTION D'EMPLOI

## ATTENTION

Si il y a une anomalie comme fumée, mauvaise odeur ou bruit anormal émis par la machine,  couper immédiatement l'interrupteur principal et débranchez le câble d'alimentation de la prise pour arrêter son fonctionnement.

- L'utilisation de l'appareil dans des conditions anormales peut provoquer un incendie ou un accident.

En cas d'anomalie

1. Mettez l'interrupteur principal sur ARRÊT.
2. Débranchez le câble d'alimentation de la prise.
3. Contactez votre revendeur le plus proche.

**Ne pas brancher le câble d'alimentation incorrectement ou le laisser être recouvert de poussière.** 

Cela pourrait nuire le câble d'alimentation.

## PRUDENCE

**Ne pas utiliser ce produit ailleurs que dans les zones industrielles.** 

- L'utiliser dans une zone résidentielle ou d'une zone à côté d'un quartier résidentiel pourrait nuire à la réception des radios, téléviseurs, téléphones, etc.
- Ne donnez pas de choc à la surface d'un produit en verre.

- S'il vous plaît ne pas jouer à ce jeu.
  - Quand vous buvez;
  - Lorsque votre condition physique n'est pas normale;
  - Lorsque vous êtes dans une période de grossesse;
  - Lorsque vous avez un contrôleur d'impulsion;
  - Lorsque vous avez récemment subi une crampe ou évanouissement en regardant la télévision.
- Évitez une force excessive / un choc pendant la lecture / de déplacer le jeu.
- Quand vous jouez les jeux, faites attention aux alentours.

**Ne pas brancher ou débrancher le câble d'alimentation avec les mains mouillées.** 

**Dans la manipulation du câble d'alimentation, suivez les instructions ci-dessous.** 

- |  |   |
|--|---|
| • Ne pas endommager le câble d'alimentation.                 | • Ne pas modifier le câble d'alimentation.            |
| • Ne pas plier le câble d'alimentation de manière excessive. | • Ne tordez pas le câble d'alimentation.              |
| • Ne pas chauffer le câble d'alimentation.                   | • Ne tirez pas sur le câble d'alimentation.           |
| • Ne pas lier le câble d'alimentation.                       | • Ne montez pas sur le câble d'alimentation.          |
| • Ne pas prendre en sandwich le câble d'alimentation.        | • Ne pas mettre un clou dans le câble d'alimentation. |

**Si la fiche du câble d'alimentation ou est endommagé, cessez immédiatement d'utiliser la machine et demandez à votre revendeur le plus proche de remplacer les pièces.**



# PRÉCAUTION D'EMPLOI

## ⚠ ATTENTION

**Assurez-vous de consulter un spécialiste de l'industrie lors de la mise en place, du déplacement ou le transport de ce produit.**

- Ce produit ne doit pas être mis en place, déplacé ou transporté par une quelconque autre qu'un spécialiste de l'industrie.
- Lors de l'installation de ce produit, installez 4 niveleurs de pieds uniformément sur le sol et assurez-vous que le produit est installé de façon stable dans une position horizontale. Une installation instable peut entraîner des blessures ou un accident.
- Lors de l'installation de ce produit, ne pas appliquer une force excessive sur les pièces mobiles. Sinon, des blessures et des accidents peuvent y résulter, ou le produit peut être endommagé.

**La machine pour une utilisation en intérieur uniquement, ne pas installer à l'extérieur.**



**N'installez pas la machine de jeu près des issues de secours.**



**Protéger la machine de jeu de:**



- L'humidité ou la pluie.
- La lumière directe du soleil.
- La chaleur directe de la climatisation et du chauffage, etc...
- Des substances inflammables dangereuses.
- Sinon, un accident ou un dysfonctionnement.

**Ne pas placer les récipients contenant des produits chimiques ou de l'eau sur ou près de la machine de jeu.**



**Ne placez pas d'objets à proximité des orifices de ventilation.**



**Ne pas plier le cordon d'alimentation par la force ou de placer des objets lourds au-dessus.**



**Ne jamais brancher ou débrancher le cordon d'alimentation avec les mains mouillées.**



**Ne jamais débrancher la machine de jeu en tirant le câble d'alimentation.**



## ⚠ PRUDENCE

**Veillez à utiliser le câblage intérieur selon les exigences de tension spécifiées. Pour une rallonge, utilisez la notation spécifiée ou plus.**

**Veillez à utiliser le cordon d'alimentation fourni.**

**Ne jamais brancher plus d'un cordon à la fois dans la prise électrique.**



**Ne pas poser le cordon d'alimentation où les gens marchent à travers.**



**Soyez sûr de mettre à la terre ce produit.**



**Ne pas exercer une force excessive lors du déplacement de la machine.**



**Pour une ventilation correcte, garder la machine de jeu 100mm (4 ") loin des murs.**

**Ne pas modifier les réglages des commutateurs DIP liées au système.**



# PRÉCAUTION D'EMPLOI

## ATTENTION

Veillez à éteindre l'interrupteur d'alimentation principale et débranchez le cordon d'alimentation de la prise avant d'inspecter ou de nettoyer la machine. 

Lors du remplacement des pièces, veillez à utiliser une partie des spécifications correctes. Ne jamais utiliser de pièces autres que celles spécifiées. 

L'ouverture à l'intérieur de la machine doit être effectuée par le spécialiste de la machine seulement, comme le courant électrique élevé est transmis à l'intérieur. Pour la machine de jeu avec le moniteur, un soin doit être pris lors de l'ouverture de sa porte arrière. Si non, une détérioration des pièces à l'intérieur ou à l'écran peut se produire. 

Si l'interrupteur secondaire du panneau de service est éteint sans éteindre le commutateur d'alimentation principale de l'unité d'alimentation, certaines parties dans les unités restent sous tension. Lors de l'ouverture de la porte arrière, veillez à éteindre l'interrupteur d'alimentation principale et débranchez le cordon d'alimentation de la prise. 

Il est strictement conseiller de s'abstenir de démonter et de réparer des pièces qui ne sont pas indiqués dans ce manuel, ainsi que les paramètres et le remodelage. 

Pour nettoyer la machine de jeu, l'essuyer avec un chiffon doux imbibé avec un détergent neutre.

- L'utilisation plus mince d'un autre solvant organique ou de l'alcool peut décomposer le matériel.
- Un choc électrique ou une défaillance de l'équipement pourraient être causés par la pénétration de l'eau à l'intérieur de la machine.

## PRUDENCE

Les composants de la machine de jeu sont sensibles aux vibrations et aux chocs. Il faut faire attention lors du déplacement et le transport de la machine de jeu. 

Veillez à ne pas laisser la machine se renverser.

Avant de déplacer la machine, veillez à éteindre l'interrupteur d'alimentation principale, débranchez le cordon d'alimentation de la prise et débranchez le cordon d'alimentation de la machine. 

Avant de déplacer la machine, la mettre hors des niveleurs et le déplacer sur les roulettes.

Éviter une force excessive lors du déplacement de la machine.

.....

## PRÉCAUTIONS LORS DU MANIEMENT

- Lors de la mise en place, l'inspection, l'entretien, déplacement ou le transport de ce produit, suivez les procédures et les instructions énoncées dans ce manuel et effectuer ce travail en toute sécurité.
- Ne pas mettre en place, manipuler, inspecter, entretenir, déplacer ou transporter ce produit dans des conditions équivalentes à l'état de "ATTENTION" ou "PRUDENCE" spécifiée dans ce manuel.
- Si un nouveau propriétaire obtient ce produit à la suite d'un transfert, etc., soyez sûr de donner ce manuel au nouveau propriétaire.

# CONTENTS

---

<b>1. SPECIFICATION AND DIMENSION</b>	P03
1-1. DIMENSION	P03
1-2. SPECIFICATION	P03
1-3. STICKER LOCATION	P04
<b>2. INSTALL INFOMATION</b>	P05
2-1. INSTALLATION SPACE	P05
2-2. MAINTAIN PRODUCT FLATNESS	P05
2-3. IMPORTANCE	P05
<b>3. COMPONENTS</b>	P06
<b>4. INSTALL</b>	P07
4-1. BILLBOARD ASSEMBLY	P07
4-2. FULL ASSEMBLY	P08
<b>5. SETUP SETTING</b>	P09
5-1. MACHINE SETUP	P09
5-2. PROGRAM SETTINGS	P10
5-3. CLEAR MODE	P15
5-4. BOOKKEEPING	P15
5-5. TEST MODE	P17
5-6. ERROR CODE	P20
5-7. ERROR CODE HOW TO DETECT ERROR	P22
<b>6. MAINTENANCE</b>	P23
6-1. PRECAUTIONS FOR TURNING ON THE POWER	P23
6-2. WHEN INSTALLING THE DEVICE	P23
6-3. MAIN BOARD MANAGEMENT	P23
6-4. BASIC PRODUCT MANAGEMENT CLEAN IT REGULARLY	P23
6-5. THIS PRODUCT SHOULD ONLY BE USED FOR INDOOR USE	P23
<b>7. EXPLODED VIEW</b>	P24
7-1. MAIN CABINET PART	P24
7-2. BILLBOARD PART	P25
7-3. MAIN BOARD PART	P26
7-4. POWER BOX PART	P26
7-5. CONTROL PANEL PART	P27
7-6. BALL PERCEIVE BASE PART	P28
7-7. BALL ROTATE PART	P29
7-8. BUTTON TABLE PART	P30
7-9. SIDE FRAME PART	P31

7-10. SPEAKER BOX PART .....	P32
7-11. SPEAKER BOX BASE PART .....	P33
7-12. SPEAKER BOX BASE PLATE PART .....	P34
7-13. CORNER TABLE-A PART .....	P35
7-14. CORNER TABLE-B PART .....	P35
7-15. CABINET COVER DOME PART .....	P36
7-16. CABINET DOOR PART .....	P37
7-17. COIN BOX PART .....	P37
<b>8. SOLUTION .....</b>	<b>P38</b>
<b>9. PCB CONNECTION LOCATION .....</b>	<b>P40</b>
9-1. MAIN PCB ASS'Y .....	P40
9-2. F407_WS2813B IO PCB ASS'Y .....	P41
9-3. FND EXT IO PCB ASS'Y .....	P41
9-4. CAN HUB PCB ASS'Y .....	P41
9-5. COLOR SENSOR IO PCB ASS'Y .....	P42
9-6. SOL FET 4CH PCB ASS'Y .....	P42
9-7. L6205 2CH_V2 PCB ASS'Y .....	P42
9-8. PHOTO INT-1 PCB ASS'Y .....	P43
9-9. COLOR SENSOR PCB ASS'Y .....	P43
<b>10. BLOCK DIAGRAM .....</b>	<b>P44</b>
<b>11. WARRANTY ITEM .....</b>	<b>P55</b>
<b>12. TROUBLE SHOOTING .....</b>	<b>P58</b>
12-1. REGION ERROR (Er01) .....	P58
12-2. SYSTEM ERROR (Er02, Er03) .....	P58
12-3. COIN MACHINE ERROR (Er.11) .....	P58
12-4. BILL ACCEPTOR ERROR (Er.13) .....	P58
12-5. COLOR SENSOR COMMUNICATION ERROR (Er.21) .....	P59
12-6. COLOR SENSOR COMMUNICATION ERROR (Er.22) .....	P59
12-7. COLOCR SENSOR I/O SENSOR ERROR (Er.23) .....	P60
12-8. MAIN SHUPPLE MOTOR & SENSOR ERROR (Er.31) .....	P60
12-9. SOLENOIDE ERROR (Er.41, Er.42, Er43, Er.44) .....	P61
12-10. MAIN SHUPPLE ERROR (Er.45) .....	P61
12-11. COLOR SENSOR ERROR (Er.51,Er.52, Er53, Er54) .....	P62
12-12. BALL LANDING RECOGNITION SWITCH ERROR (Er.61, Er.62, Er.63, Er.64) .....	P62
12-13. SOLENOID EXCEPTION HANDLING ERROR (Er.71, Er.72, Er.73, Er.74) .....	P63
12-14. TICKET ERROR (HELP) .....	P63

# 1. SPECIFICATION AND DIMENSION

## 1-1. DIMENSION

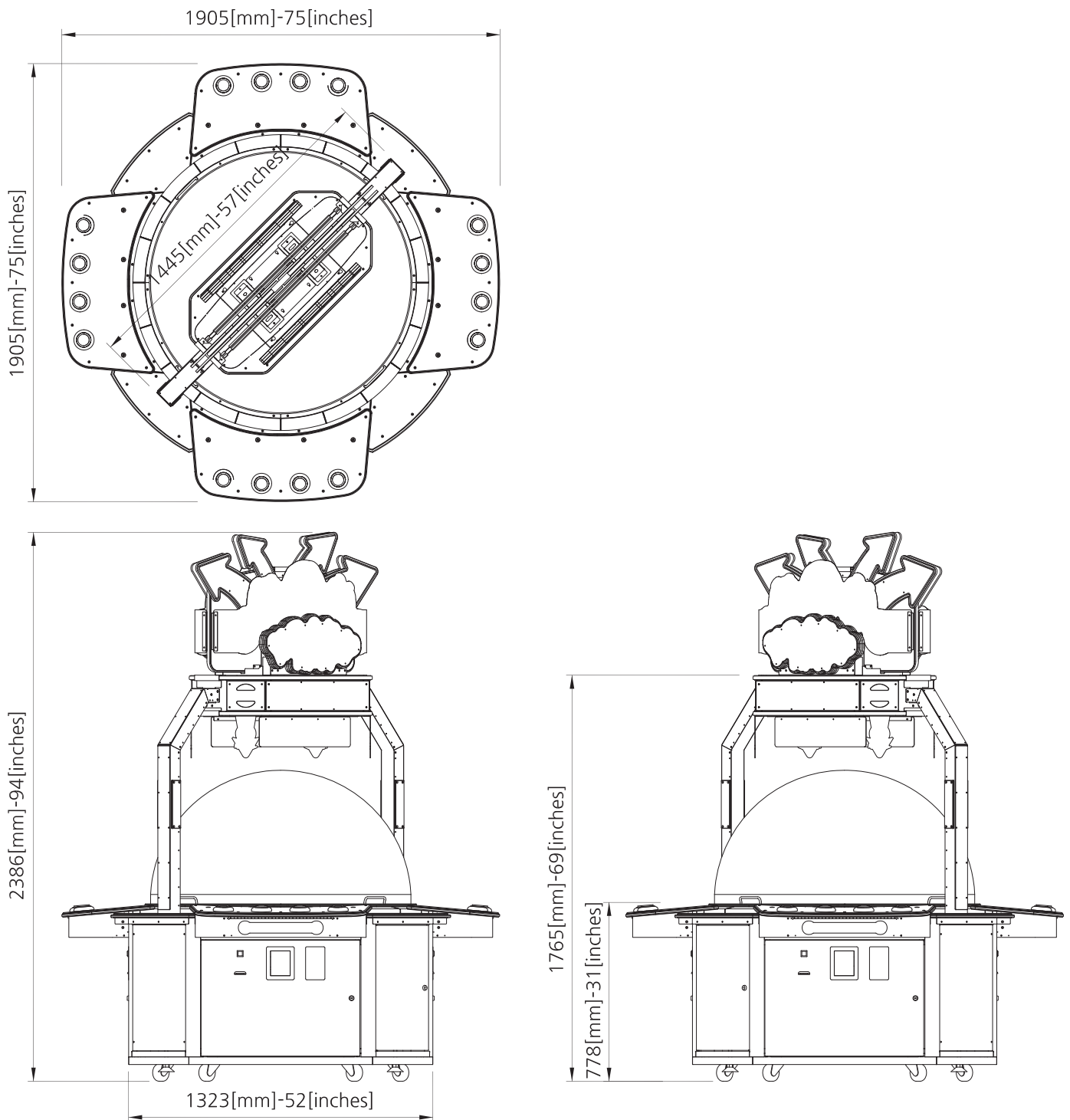

## 1-2. SPECIFICATION

DIMENSIONS (W x D x H)	1905 x 1905 x 2386 (mm)	
PACKING DIMENSIONS (W x D x H)	MAIN BODY : 1440 x 1440 x 2010 (mm) ETC : 860x 1440 x 910 (mm)	
WEIGHT (kg)	354 kg [ WEIGHT INCLUDING : 414 kg ] PACKAGING	
VOLTAGE	AC 120V	AC 230V
FREQUENCY RANGE	60Hz	50/60Hz
CONSUMPTION	850 W	
CERTIFICATION	-	

# 1-3. STICKER LOCATION

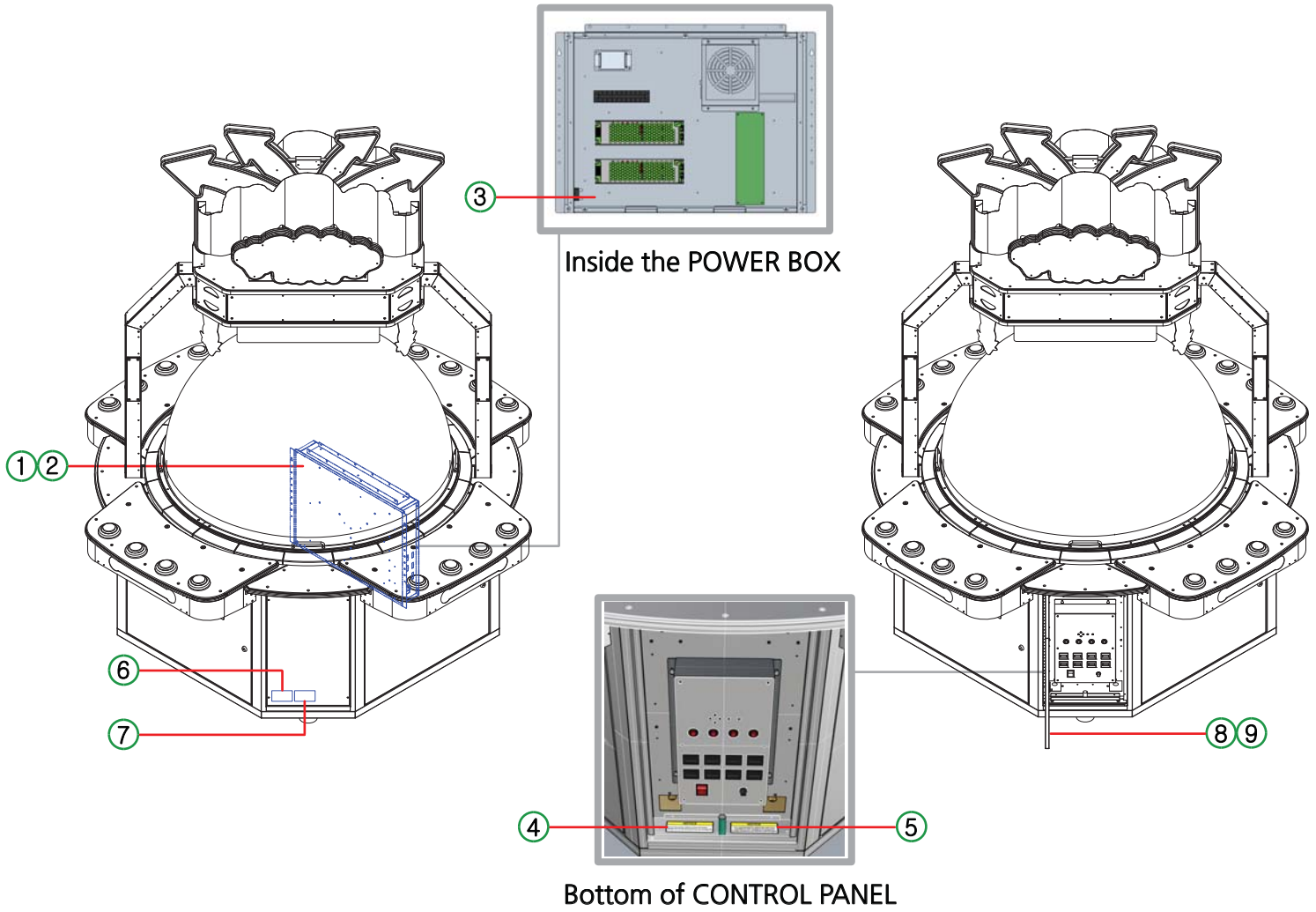

**1**

**⚠ WARNING/ATTENTION**

Except service personnel, please never open the product as there is a risk of electric shock.

Il y a un risque d'électrocution, n'ouvrez pas le produit excepté le responsable, s'il vous plaît.

**2**

**⚠ CAUTION/PRUDENCE**

\*For continuous protection against risk of fire, replace only with the same type T10A-250V fuse\*

\*Pour une protection continue contre les risques d'incendie, remplacer un fusible avec seulement le même type T10A-250V\*

**3**



**4**

**NOTICE**

To turn the power switch on from off status, Please try it in 10 seconds from your turning Off

**5**

**NOTICE**

It is recommended to replace the balls every 3 months as color sensing errors caused by foreign substances can interfere with the game.

**6**



**7**

**WARNING**

ROCKING, SHAKING, OR TIPPING MAY CAUSE INJURY OR DEATH!!

This unit must be fastened securely to the wall, floor or adjacent object in compliance with the installation instructions.

**ATTENTION**

AGITER, SECOUER OU BASCULER PEUT CAUSER DES BLESSURES OU ENTRAINER LA MORT!!

Cette unité doit être fixée au mur, au plancher ou à un objet à proximité conformément aux instructions d'installation.

**8**



**9**

MODEL NAME	
PRODUCT S/N	
MAIN BOX S/N	
LOD S/N	
CERTIFICATE	
MADE IN KOREA	
Koyang-si, Kyonggi-do, Korea. Phone:82-31-908-2100	

## 2. INSTALL INFORMATION

**\* PLEASE DO NOT INSTALL PRODUCT IN A PLACE WITH A LOT OF SUNLIGHT. IT CAN BE A PROBLEM FOR THE OPERATION OF THE PRODUCT.**

### 2-1. INSTALLATION SPACE

- ※ Maintenance zone & Play zone should have at least 2900mm(114 inch) \* 2900mm(114 inch) each

### 2-2. MAINTAIN PRODUCT FLATNESS

- ※ After installation is complete
- ※ 2-1 After securing space, adjust the 4 adjuster so that the product is stably leveled

### 2-3. IMPORTANCE



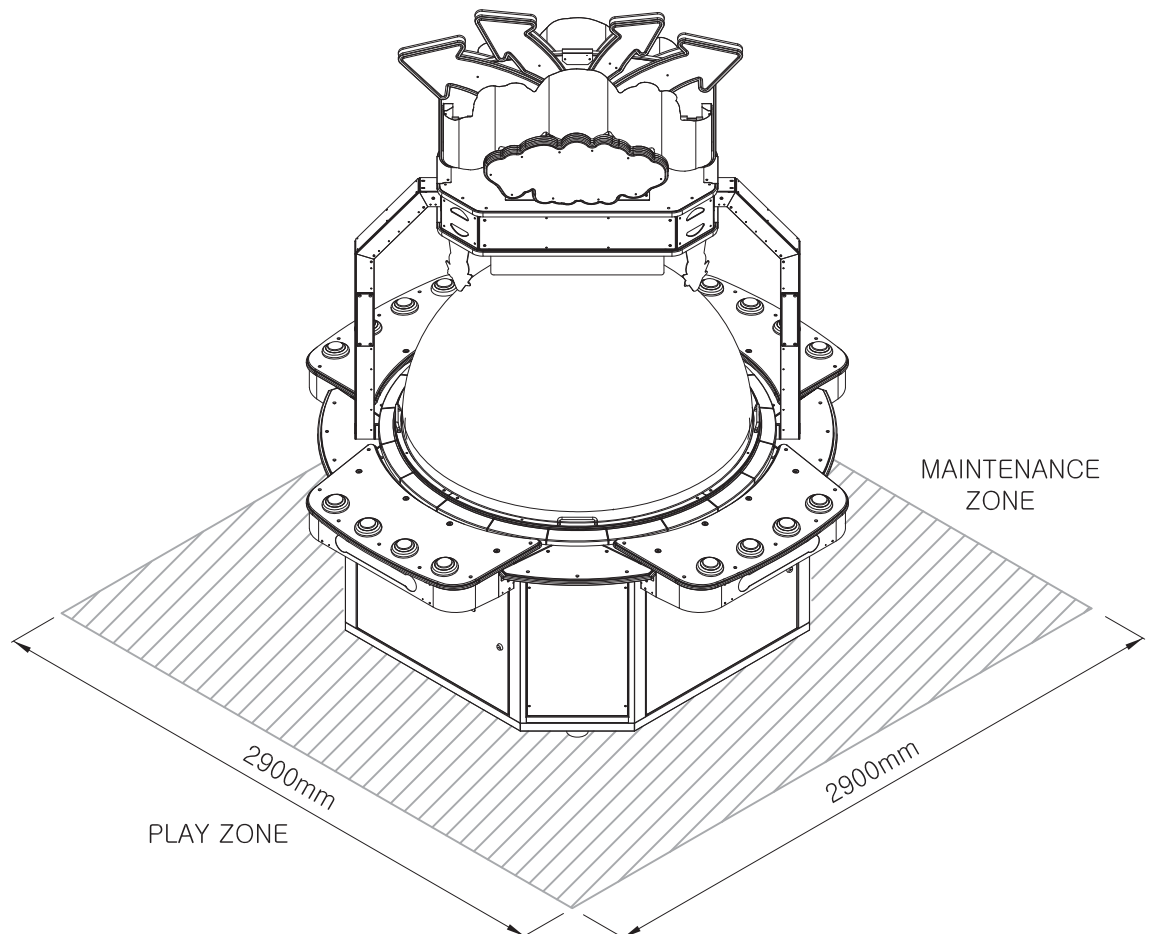







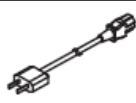









- ※ This product should be indoor use and out of direct sunlight



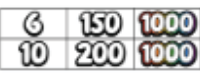

### 3. COMPONENTS

NO	PART NAME	Q'TY	SPARE	NO	PART NAME	Q'TY	SPARE
1	AC POWER CORD ASS'Y	1	-	14	SCREW FH NI [M4x12L]	12	4
2	BILLBOARD CHARACTER FIX BKT	4	-	15	SCREW TH NI [M4x8L]	20	4
3	KEY 7001	2	-	16	SCREW FH NI [M5x25L]	4	2
4	KEY 6001	2	-	17	SCREW FH NI [M6x30L]	-	4
5	RENCH [2.5mm]	1	-	18	SEMS NI [M6x16L]	48	4
6	RENCH [3mm]	1	-	19	FLANGE NUT [M4]	12	4
7	RENCH [4mm]	1	-	20	STICKER REMOVER	1	-
8	RENCH [5mm]	1	-	21	BUFFING TOWEL	1	-
9	BALL (RED) Ø80	8	16	22	DONUT CUSHION	1	-
10	BALL (GREEN) Ø80	8	16	23	SIDE FRAME TICKET SCORE ACRYL_R_BLANK	1	-
11	BALL (BLUE) Ø80	8	16	24	SIDE FRAME TICKET SCORE ACRYL_G_BLANK	1	-
12	BALL (YELLOW) Ø80	8	16	25	SIDE FRAME TICKET SCORE ACRYL_B_BLANK	1	-
13	BALL (PURPLE) Ø80	6	12	26	SIDE FRAME TICKET SCORE ACRYL_Y_BLANK	1	-
				27	SIDE FRAME TICKET SCORE ACRYL_STICKER_INT	1	-
				28	FUSE 6.3A [0218006.3.MXP]	4	-
				29	MANUAL	1	-

▼ 1	▼ 2	▼ 3,4	▼ 5,6,7,8	▼ 9,10,11,12,13	▼ 14
					
▼ 15	▼ 16	▼ 17	▼ 18	▼ 19	▼ 20
					
▼ 21	▼ 22	▼ 23	▼ 24	▼ 25	▼ 26
					
▼ 27	▼ 28	▼ 29			
					



# 4. INSTALL

## 4-1. BILLBOARD ASSEMBLY

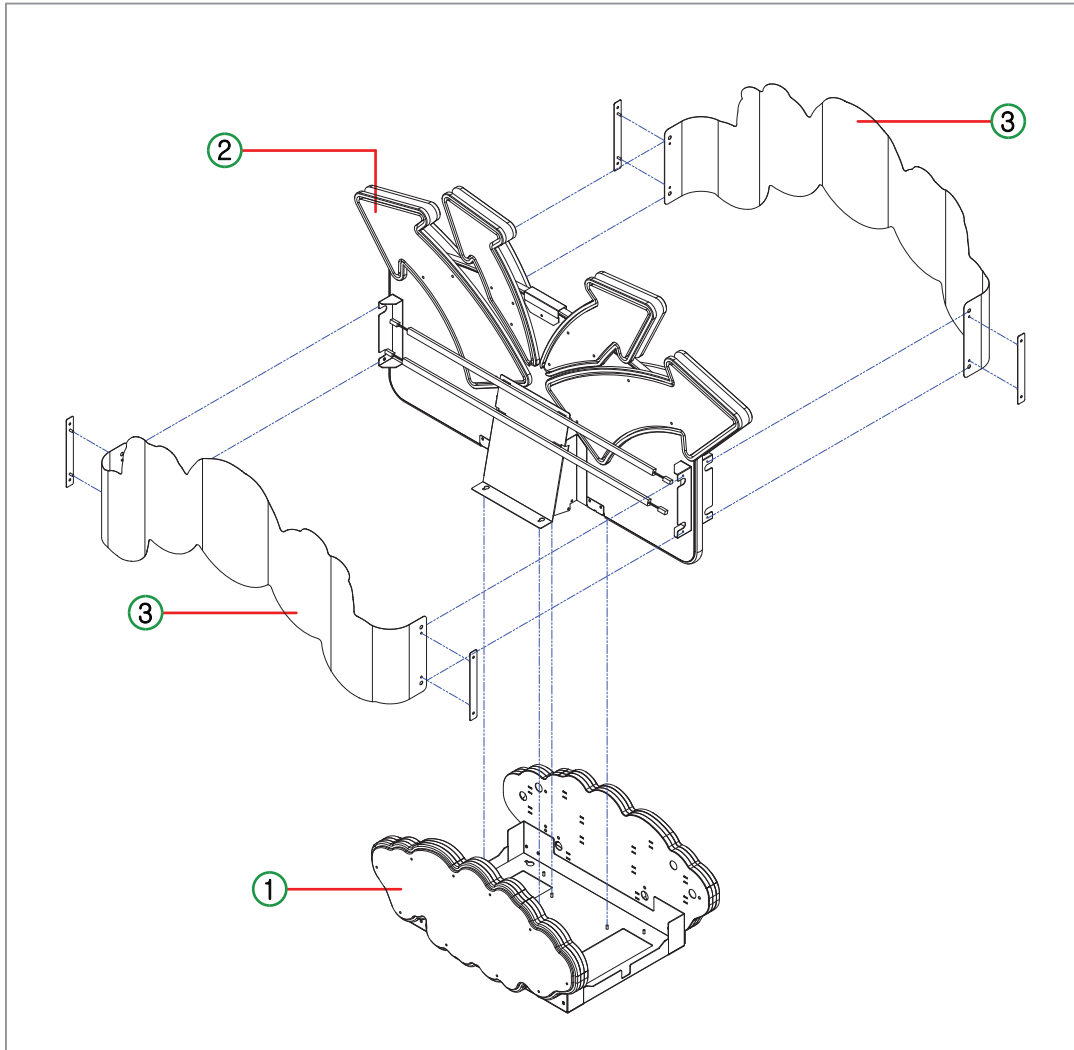

NO	PROCESS	ITEM	Q'TY	BOLT	SPEC	Q'TY
1		BILLBOARD BASE ASS'Y	1			
2	ASSEMBLE	BILLBOARD BACKGROUND ASS'Y	1	FLANGE NUT	M4	4
3	ASSEMBLE	BILLBOARD FRONT FOMAX MIDDLE FIX BKT	2	SCREW TH NI	M4x8L	8
				FLANGE NUT	M4	8

## 4-2. FULL ASSEMBLY

\* Connector location

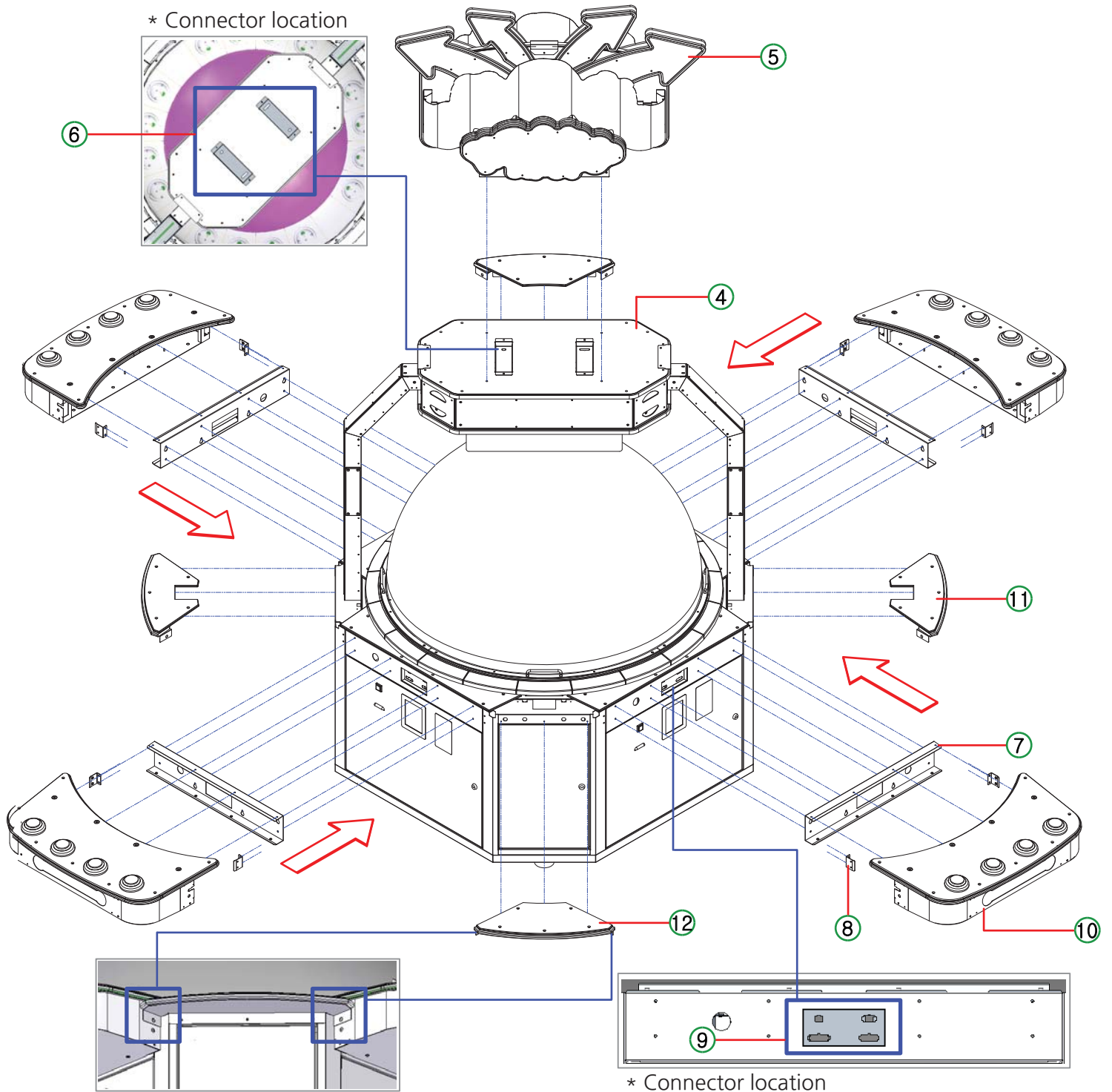

\* Connector location

NO	PROCESS	ITEM	Q'TY	BOLT	SPEC	Q'TY
4	ASSEMBLE	CABINET ASS'Y	1			
5	ASSEMBLE	BILLBOARD ASS'Y	1	SCREW FH NI	M5x30L	4
6	CONNECTION	BILLBOARD CONNECTOR				
7	ASSEMBLE	BUTTON TABLE FIX BKT	4	SEMS NI	M6x16L	8
8	ASSEMBLE	BUTTON TABLE FIX SUPPORT BKT	8	SEMS NI	M6x16L	16
9	CONNECTION	BUTTON TABLE CONNECTOR				
10	ASSEMBLE	BUTTON TABLE ASS'Y [1~4P]	4	SCREW FH NI SEMS NI	M6x30L M6x16L	16 16
11	ASSEMBLE	CORNER TABLE PART-A	2	SCREW TH NI SCREW FH NI SEMS NI	M4x8L M4x12L M6x16L	6 4 4
12	ASSEMBLE	CORNER TABLE PART-B	2	Same as NO. 11		

\*Reuse of fixing bolts

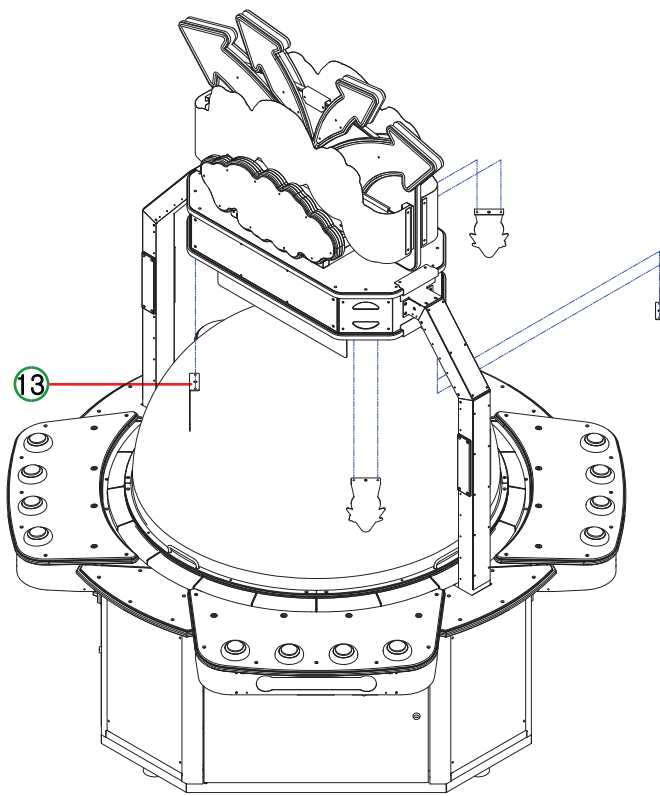

NO	PROCESS	ITEM	Q'TY	BOLT	SPEC	Q'TY
13	ASSEMBLE	BILLBOARD BOTTOM ARROW ACRYL	4	SCREW TH	M4x14L	8

## 5. SETUP SETTING

### 5-1. MACHINE SETUP

#### 1.SETUP BUTTON LAYOUT

	<ol style="list-style-type: none"> <li>1) [↑↓] UP/DOWN KEY : MENU UP/DOWN MOVE</li> <li>2) [←→] LEFT/RIGHT KEY : CHANGE SETTING VALUE</li> <li>3) MENU/SELECT KEY : SET UP MENU MODE, SELECT AND PERFORM</li> <li>4) CANCEL KEY : EXIT</li> </ol>
	<p>NORMALLY SERVICE IN, IN CASE OF ERROR, USE THIS BUTTON TO CLEAR ERROR</p> <p>* EACH TIME SERVICE IN IS PRESSED ONCE, 1 CREDIT UP</p>

### OPERATING OPTIONS

PRESS MENU BUTTON. [MENU/SELECT BUTTON: ENTER]	
PROGRAM SETTINGS	MODE FOR SETTING
CLEAR MODE	MODE FOR CLEAR
BOOKKEEPING	CHECKING GAME DATA
FACTORYSETTING	INITIALIZING TO FACTORY SETTING
TESTMODE	MODE FOR TESTING
EXIT	EXIT OPERATION OPTIONS

## 5-2. PROGRAM SETTINGS

LCD DISPLAY	DESCRIPTION	RANGE	DEFAULT
CREDITS / COIN	SET CREDIT(S) / COIN ※ Clear GameData when saved after change	“FREE”, 1/1, 1/2, 1/3, 1/4, 1/5, 2/1, 3/1, 4/1, 5/1, 6/1, 7/1, 8/1, 9/1, 10/1	1/1
CREDITS / BILL	SET CREDIT(S) / BILL ※ Clear GameData when saved after change	1, 2, 3, 4, 5, 6, 7, 8, 9, 10	1
GAME TIME	SET TIME OVER TIME	10 ~ 99 (SECOND)	40
WAIT TIME	Set waiting times for other players when coin-in or card swiping (If no player enters after waiting time, play the game)	1 ~ 20 (SECOND)	8
ATTRACT TIME	Set the operating cycle of the attraction time (shuffle motor, solenoid) in demo mode	“OFF” / “5MIN” / “10MIN” “30MIN” / “1HRS” / “3HRS”	“30MIN”
SP-BNS SCORE ※ DIP	SET SUPER BONUS ※ Table #2 and Table #5 when changing DIP S/W SP-BNS The SCORE value is automatically applied, but When changing the setting value in this item, see Table #2 and Than the SP-BNS SCORE value in Table #5 It will be applied with priority	30 ~ 9999 (10 UNIT INCREASE)	1000
DIFFICULTY	Set the level of difficulty <b>EASY</b> : AI's own ball and WILD ball Each is sent out twice <b>NORMAL</b> : AI's own ball and WILD ball Each is exported once <b>HARD</b> : AI's own ball and WILD ball Equal to users without exporting Proceed with the game “Even if you set the difficulty level, internally It changes automatically depending on the payout.”	“EASY” “NORMAL” “HARD”	NORMAL
TARGET SCORE ※ DIP	Set your own color ball winning score for each hole	=> (Sub menu) (Refer to Table #1)	
MERCY TICKET ※ DIP	Set the score when you don't get any of your own colored balls at the completion of the game (including wild balls) ※ When changing DIP S/W, the MERCY TICKET values in Table #2 and Table #5 are automatically applied When changing the setting value in this item, see Table #2 and Than the MERCY TICKET value in Table #5 It will be applied with priority	0 ~ 20 (1 UNIT INCREASE)	1
FIXED TICKET ※ DIP	Regardless of the win or loss, only the fixed number of tickets will be paid (If FIXED TICKET is set, SP-BNS SCORE, BIGWIN, MERCY TICKET Even if it is set, the FIXED TICKET setting value is payment has been processed)	“OFF”, “1” ~ “20” (1 UNIT INCREASE)	OFF
TICKET/SCORE	Set TICKET / SCORE NONE: Automatically reduce ticket count without using ticket out	"NONE", "1/1", "1/2"	1/1

ATTRACT VOLUME	Enable DEMO sound and set volume "OFF" : No sound 10 ~ 100 : Sound volume	"OFF", 10 ~ 100 (10 UNIT INCREASE)	<b>60</b>
SAVE AND EXIT	Save and exit	BY PRESSING SELECT BUTTON, PERFORM BY MOVING THE CURSOR TO [YES] or [NO]	
CANCEL AND EXIT	Cancel and exit		
<p>※ The default values of DIP display items are set to DIP S/W (KSD04H) settings ①, ②, ③, and ④. So it may vary. For more details, please refer to &lt;Table #1 DIP S/W Setting Default Value&gt; below.</p> <p>※ After changing the DIP SW, you must proceed with "FACTORY SETTING" to ensure that the DIP SW changed value is Applies.</p>			

## <Table #1>

### ● PROGRAM SETTINGS -> TARGET SCORE

#### <DIP S/W SETTING DEFAULT VALUE>

- DIP SW. When changing the destination according to setting number 6, please proceed by selecting one of the items below.

1. Change DIP SW 6 destination and run FACTORY SETTING
2. If an error occurs by changing the direction of DIP SW 6 and turning the power OFF -> ON, Execute FACTORY SETTING

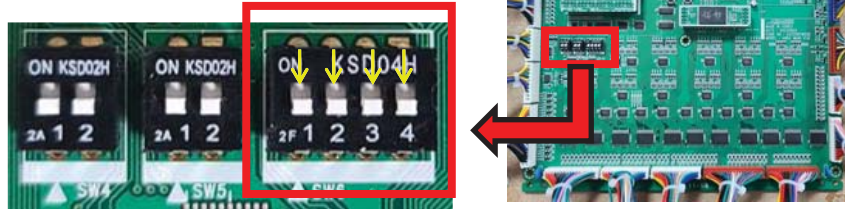

<Default value when FACTORY SETTING after setting DIP S/W KSD04H ①, ②, ③, ④>

	A (Refer to Table2)	B (Refer to Table3)	C (Refer to Table4)	D (Refer to Table5)
DIP ①	OFF	ON	OFF	OFF
DIP ②	OFF	OFF	OFF	OFF
DIP ③	OFF	OFF	ON	OFF
DIP ④	OFF	OFF	OFF	ON

LCD DISPLAY	DESCRIPTION	RANGE	DEFAULT			
			A	B	C	D
PRESET TYPE	Preferred score table reference settings "Refer to Table#2 ~ #5"	0 ~ 2 (1 UNIT INCREASE)	0 "Refer to Table2"	0 "Refer to Table3"	0 "Refer to Table4"	0 "Refer to Table5"
BIGWIN	Set the winning score for the 1st place	0 ~ 9999 (1 UNIT INCREASE)	100	100	25	200
1 BALL	Set the ticket score when you have one colored ball. (With wild ball)	0 ~ 999 (1 UNIT INCREASE)	5	10	3	5
2 BALLS	Set the ticket score when you have two colored balls. (With wild ball)	0 ~ 999 (1 UNIT INCREASE)	10	20	5	10
3 BALLS	Set the ticket score when you have three colored balls. (With wild ball)	0 ~ 999 (1 UNIT INCREASE)	15	30	7	15
4 BALLS	Set the ticket score when you have four colored balls. *Even if you don't get 1st place, but you collect 4 balls of your own color (With wild ball)	0 ~ 999 (1 UNIT INCREASE)	20	40	9	20
SAVE AND EXIT	SAVE AND EXIT	BY PRESSING SELECT BUTTON, PERFORM BY MOVING THE CURSOR TO [YES] or [NO]				
CANCEL AND EXIT	CANCEL AND EXIT					

<Table #2>

PRESET TYPE A

PRESET TYPE	0	1	2
AVERAGE	38.4	50.5	67.0
SP-BNS SCORE	1000	1000	1000
BIGWIN SCORE	100	150	200
1 BALL SCORE	5	6	10
2 BALLS SCORE	10	12	20
3 BALLS SCORE	15	18	30
4 BALLS SCORE	20	24	40
MERCY TICKET	1	2	4
FIXED TICKET	OFF	OFF	OFF

<Table #3>

PRESET TYPE B

PRESET TYPE	0	1	2
AVERAGE	56.0	91.8	122.9
SP-BNS SCORE	2000	2000	3000
BIGWIN SCORE	100	200	300
1 BALL SCORE	10	20	20
2 BALLS SCORE	20	40	40
3 BALLS SCORE	30	60	60
4 BALLS SCORE	40	80	80
MERCY TICKET	4	6	8
FIXED TICKET	OFF	OFF	OFF

<Table #4>

PRESET TYPE C

PRESET TYPE	0	1	2
AVERAGE	11.5	13.6	16.4
SP-BNS SCORE	200	200	200
BIGWIN SCORE	25	30	35
1 BALL SCORE	3	3	4
2 BALLS SCORE	5	6	8
3 BALLS SCORE	7	9	12
4 BALLS SCORE	9	12	16
MERCY TICKET	1	2	2
FIXED TICKET	OFF	OFF	OFF



<Table #7>

PRESET TYPE D

PRESET TYPE	0	1	2	3	4	5
AVERAGE	38.5	45.9	56.4	59.5	70.0	77.4
SP-BNS SCORE	1000	1000	1000	1000	1000	1000
BIGWIN SCORE	100	100	150	200	250	250
1 BALL SCORE	5	10	10	5	5	10
2 BALLS SCORE	10	20	20	10	10	20
3 BALLS SCORE	15	30	30	15	15	30
4 BALLS SCORE	20	40	40	20	20	40
MERCY TICKET	2	2	2	2	2	2
FIXED TICKET	OFF	OFF	OFF	OFF	OFF	OFF

★ SCORE TYPE is a FACTORY SET with door handle and DIP S/W KSD04H ①, ②, ③, ④ settings.  
Under changed circumstances, FACTORY SET was started only once for the first time.

### 5-3. CLEAR MODE

● CLEAR MODE		
* GAME DATA AND BOOKKEEPING CAN BE DELETED		
LCD DISPLAY	DESCRIPTION	EXECUTION
CLEAR TICKETS	DELETE REMAINING TICKETS TO BE DISPENSED NOW	BY PRESSING SELECT BUTTON, PERFORM BY MOVING THE CURSOR TO [YES] or [NO]
CLEAR CREDITS	DELETE REMAINING PLAYS (CREDITS)	
CLEAR DATA	GAME ALL GAME DATA AND BOOKKEEPING DATA INCLUDING CREDITS AND TICKETS	
EXIT	EXIT	

### 5-4. BOOKKEEPING

● BOOKKEEPING	
LCD DISPLAY	DESCRIPTION
1P : 1 Player 2P : 2 Player TOTAL : 1P, 2P TOTAL	
-- COIN IN [1/2] -- 1P: 0 2P: 0	1P, 2P COIN IN
-- COIN IN [2/2] -- 3P: 0 4P: 0 TOTAL: 0	3P, 4P AND TOTAL COIN IN
-- BILL IN [1/2] -- 1P: 0 2P: 0	1P, 2P BILL IN
-- BILL IN [2/2] -- 3P: 0 4P: 0 TOTAL: 0	3P, 4P AND TOTAL BILL IN
- SERVICE IN [1/2] - 1P: 0 2P: 0	1P, 2P SERVICE IN. 1 PLAY UP BY PRESSING SERVICE IN
- SERVICE IN [2/2] - 3P: 0 4P: 0 TOTAL: 0	3P, 4P AND TOTAL SERVICE IN. 1 PLAY UP BY PRESSING SERVICE IN
- GAME PLAYS [1/2] - 1P: 0 2P: 0	1P, 2P GAME PLAY COUNT

- GAME PLAYS [2/2] - 3P: 0 4P: 0 TOTAL: 0	3P, 4P AND TOTAL GAME PLAY COUNT.
- TICKET OUT [1/2] - 1P: 0 2P: 0	1P, 2P TICKET OUT COUNT.
- TICKET OUT [2/2] - 3P: 0 4P: 0 TOTAL: 0	3P, 4P AND TOTAL TICKET OUT COUNT.
-- BIGWIN [1/2] -- 1P: 0 2P: 0	1P, 2P BIGWIN COUNT
-- BIGWIN [2/2] -- 3P: 0 4P: 0 TOTAL: 0	3P, 4P AND TOTAL BIGWIN COUNT
-- SP-BNS [1/2] -- 1P: 0 2P: 0	1P, 2P SUPER BONUS COUNT
-- SP-BNS [2/2] -- 3P: 0 4P: 0 TOTAL: 0	3P, 4P AND TOTAL SUPER BONUS COUNT
-- TRY AGAIN [1/2] -- 1P: 0 2P: 0 TOTAL: 0	1P, 2P TRY AGAIN COUNT
-- TRY AGAIN [2/2] -- 3P: 0 4P: 0 TOTAL: 0	3P, 4P AND TOTAL TRY AGAIN COUNT
-- PLAY INFO [1/2] -- PSINGLE : 0 DOUBLE : 0	SINGLE: Number of times played by 1 user DOUBLE: Number of times played by 2 users
-- PLAY INFO [2/2] -- TRIPLE : 0 QUAD : 0 TOTAL: 0	TRIPLE: Number of times played by 3 user QUAD: Number of times played by 4 users
----- VER INFO -----	VERSION INFORMATION
CANCEL BUTTON : EXIT	

● FACTORY-SETTING

INITIALIZE TO FACTORY SETTING VALUE (DELETE DATA AND SET TO GAME DEFAULT VALUE)

LCD DISPLAY (PERFORM)	LCD DISPLAY (PERFORM)
-----------------------	-----------------------

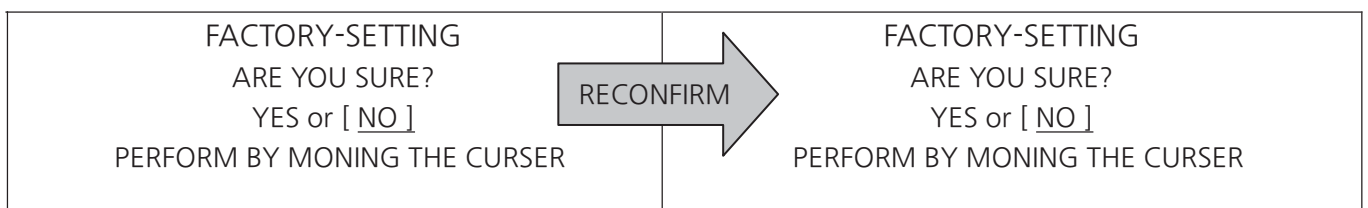

## 5-5. TEST MODE

TEST ITEM	SETTING ITEM	DESCRIPTION	
INPUT TEST	[=>]	GO TO INPUT TEST	
		Display in the Input Status LCD window for each item	
		(BUTTON, COIN, TICKET, SENSOR... ETC)	
		CREDIT FND [■ ■] : Show each player number ("1P", "2P", "3P", "4P") <Displayed when the game button is pressed>  TICKET FND [■ □ □ □] : Button 1 input status display ( FND top lights up ) [□ ■ □ □] : Button 2 input status display ( FND top lights up ) [□ □ ■ □] : Button 3 input status display ( FND top lights up ) [□ □ □ ■] : Button 4 input status display ( FND top lights up ) [■ ■ ■ ■] : Button 5 input status display ( Lights up in the middle of FND )	
		<Sensor for ball landing recognition Displayed when ball is recognized> TICKET FND [□.□.□.□.] : When the ball is recognized by the ball landing recognition sensor, a dot is displayed on the TICKET FND	
FND & LAMP	LAMP, FND, LED TEST		
	"OFF"	ALL OFF	
	"STEP"	LAMP	▶ ALL ON, OFF FLASHING ▶ BILLBOARD SPOT LAMP ON ▶ 1P/2P KRAZY BALLZ TITLE SPOT LAMP ON ▶ 1P/2P BILLBOARD BAR SPOT LAMP ON ▶ 1P/2P BILLBOARD LOGO SPOT LAMP ON ▶ 1P/2P HOW TO PLAY SPOT LAMP ON ▶ 3P/4P KRAZY BALLZ TITLE SPOT LAMP ON ▶ 3P/4P BILLBOARD BAR SPOT LAMP ON ▶ 3P/4P BILLBOARD LOGO SPOT LAMP ON ▶ 3P/4P HOW TO PLAY SPOT LAMP ON Repeat in order above
		FND	▶ ALL ON, OFF FLASHING ▶ CREDIT [00] ▶ TICKET [1111] ▶ ENTIRE NUMBER COUNTING [0000] ~ [9999] Repeat in order above
		LED	▶ ALL WHITE ON, OFF FLASHING ▶ RED ▶ GREEN ▶ BLUE ▶ WHITE TURN ON IN ORDER
	"ON"	▶ All LEDs except the 2, 3, 4P button board and game hole are turned on ▶ The corresponding play zone button board and game hall are turned on with the game button for each P	
	"ON/OFF"	ALL ON, OFF REPEAT	
MOT SHUPPLE	Test the operation of the main drive motor ◎ When you press the SELECT button, it changes to CW/CWW mode and operates in the CW direction. ◎ When selecting a type with the LEFT and RIGHT buttons, it operates in the corresponding item menu. (Game button number 1 for each P functions as a motor ON/OFF function) (Game button number 4 for each P has CW/CCW change function) (Game button number 4 and SERVICE button for each P operate with the same function)		
	"OFF"	MAIN MOTOR OFF	
	"CW/CCW"	Main motor forward and reverse automatic operation	
	"CHECK"	Check the operating speed of the main motor	

	<p>CREDIT FND [■ ■] : Display main motor status (“On”, “OF”, “CH”)          &lt;Display TICKET FND when setting is ON &gt;          TICKET FND [■ □ □ □] : Displays main motor operation status          (0: stop, 1: forward, 2: reverse)              [□ ■ □ □] : Display status of main motor sensor (0, 1)              [□ □ ■ ■] : Display count of sensor check of main motor</p> <p>&lt; Display TICKET FND when setting is CHECK &gt;          TICKET FND [■ ■ ■ ■] : Display speed of the main motor (UNIT 1/1000 SEC)</p>	
SOLENOID	<p>Solenoid manual operation test          ◎ Press the SELECT button to change to MANUAL mode, and press the individual game button to solenoid operation          ◎ When selecting a type with the LEFT and RIGHT buttons, it operates in the corresponding item menu</p>	
	“OFF”	Solenoid stop
	“AUTO”	Solenoid Auto Test
	“MANUAL”	Manual testing of solenoids (test by pressing individual game buttons)
	<p>CREDIT FND [■ ■] : Display solenoid operation status (“OF”, “On”, “At”)          &lt;Display TICKET FND when setting value is MANUAL&gt;          TICKET FND [■ ■ ■ ■] : Solenoid operated number display          (1P-1, 1P-2...4P-3, 4P-4)          &lt;TICKET FND display when setting value is AUTO&gt;          TICKET FND [■ ■ ■ ■] : Solenoid operation count display</p>	
COLOR SENSOR	<p>Testing of color sensors and switch sensors for ball landing recognition          ◎ Press the SELECT button to turn it on and off</p>	
	“OFF”	Color sensor and ball landing recognition switch sensor stop
	“ON”	Color sensor and switch sensor operation for ball landing recognition
		<p>CREDIT FND [■ ■] : Color sensor and switch for ball landing recognition          Display sensor operation status (“On”, “OF”)          TICKET FND [■ ■ ■ ■] : Display color sensor ball recognition color          (Shows 1, 2, 3, 4, 5, E)          (1 : RED, 2 : GREEN, 3 : BLUE, 4 : YELLOW, 5 : WILD, E : ERROR)          TICKET FND [□ . □ . □ . □ .] : When the ball is recognized by the switch sensor for ball landing recognition, a dot is displayed on the TICKET FND</p>
COIN	<p>Coin acceptor test          ◎ Press the SELECT button to turn on and off together 1P, 2P, 3P, 4P          ◎ Individual On, Off operation with game button for each P</p>	
	“ON”, “OFF”	Coin acceptor ON, OFF
		<p>CREDIT FND [■ ■] : Display Coin Sensor Check Count (00 ~ 99 Repeat counting)          TICKET FND [■ □ □ □] : Display Coin Sensor Power Status (0 or 1)              [□ ■ □ □] : Display coin sensor status (0 or 1)              [□ □ ■ ■] : Coin sensor check count display (repeat 00 to 99 counts)</p>
BILL	<p>Bill acceptor test          ◎ Press the SELECT button to turn on and off together 1P, 2P, 3P, 4P          ◎ Individual On, Off operation with game button for each P</p>	
	“ON”, “OFF”	Bill acceptor ON, OFF
		<p>CREDIT FND [■ ■] : Display Bill Sensor Check Count (00 ~ 99 Repeat counting)          TICKET FND [■ □ □ □] : Display Bill Sensor Power Status (0 or 1)              [□ ■ □ □] : Display bill sensor status (0 or 1)              [□ □ ■ ■] : Banknote acceptor sensor check count display          (repeat count from 00 to 99)</p>

T-KET (TICKET)	Ticket dispenser test ◎ Select the type with the LEFT and RIGHT buttons and press the SELECT button to test ◎ Individual ticket operation with 1P, 2P, 3P, 4P SERVICE, ticket non-dispensing button, and game button (3 tickets issued)	
	"ALL"	All player ticket dispenser test (3 tickets out)
	"1P", "2P", "3P", "4P"	1P, 2P, 3P, 4P Individual Ticket dispenser test (3 tickets out)
	CREDIT FND [■□] : Display ticket button status (0, 1) [□■] : Display ticket sensor status (0, 1) TICKET FND [□□□■] : Display ticket dispensed count	
COUNTER	COUNTER TEST ◎ Select type with LEFT and RIGHT buttons and press SELECT button to increase 1 counter ◎ Select the type with the LEFT and RIGHT buttons and press each player's SERVICE button to increase the corresponding player 1 counter	
	"COIN"	All player coin counter action when SELECT button is pressed 1P ► 2P ► 3P ► 4P increases by 1 coin counter in order. Individual player coin counter action when SERVICE button is pressed The corresponding SERVICE button player coin counter 1 goes up.
	"TICKET"	All player ticket counter action when SELECT button is pressed 1P ► 2P ► 3P ► 4P increases by 1 ticket counter in order. Individual player ticket counter action when SERVICE button is pressed The corresponding SERVICE button player ticket counter 1 goes up.
SOUND TEST	Sound test ◎ Select the type with the LEFT and RIGHT buttons and test with the SELECT buttons (play, stop) ◎ Operates to move to the next sound with the game button for each P	
	"CH"	One, Two, ~Four voice output for each channel speaker 1P LEFT : 1 2P RIGHT : 2 3P LEFT : 3 4P RIGHT : 4
	"BGM"	BGM VOLUME TEST
	"SFX"	SOUND EFFECT VOLUME TEST
	"VOC"	VOICE VOLUME TEST
	CREDIT FND [■■] : Sound playback status indication ("On", "OF") TICKET FND [■■□□] : Sound information display ("CH", "No") [□□■■] : Sound play count display	
EXIT	EXIT TO OPERATING OPTIONS	

## 5-6. ERROR CODE

Only "Er.01", "Er.02", "Er.03", "Er.31", and "Er.45" will stop the entire game, and other errors will stop playing only the player with the error.

"Ticket error" does not stop gameplay, only the "HELP" message is displayed.

ERROR CODE	ERROR TYPE	DESCRIPTION	CHECK POINT
Er.01	BY REGION	Location mismatch between setup save data and MAIN PCB DIP SW	1. Check MAIN PCB DIP SW location 2. Execute FACTORY SET 3. If the problem persists, replace the motherboard
Er.02	SYSTEM	Setup save data problem	1. Verifying and saving setup settings 2. Initializing Factory setting 3. Check power ON, OFF 4. Replace Main PCB
Er.03		Game save data problem	1. Do clear data in clear mode 2. Check power ON, OFF 3. Replace Main PCB
Er.11	COIN ACCEPTOR	Player coin sensor signal still on	Check the input of the player coin acceptor sensor
Er.13	BILL ACCEPTOR	Player bill sensor signal still on	Check the input of the player bill acceptor sensor
Er.21	COLOR SENSOR COMMUNICATION	Color sensor communication problem	1. Check wires 2. Check Main PCB, Color sensor I/O board 3. Replace the boards
Er.22		Color sensor protocol version incorrect	Between the main board and the color sensor IO board Protocol version does not match
Er.23	COLOR SENSOR IO	Color sensor IO board internal error	1. Color sensor IO board replacement 2. Check wiring 3. Replacing a sensor that does not recognize color 4. Check power ON and OFF
Er.31	MAIN(SHUFFLE) MOTOR	Encoder signal off or still on	1. Check motor status 2. Check SMPS power 3. Check encoder sensor
Er.41	SOLENOID	#1 Solenoid operation problem	1. Check solenoid status 2. Check wires 3. Check SMPS power 4. Check power ON, OFF
Er.42		#2 Solenoid operation problem	
Er.43		#3 Solenoid operation problem	
Er.44		#4 Solenoid operation problem	
Er.45		For recognition of ball landing in each hole during game play Switch sensor ball recognition number issue	1. Check the operation status of the main (shuffle) device 2. Check the number of balls of each color 3. Switch sensor for ball landing recognition Check operation status
Er.51	COLOR SENSOR	#No. 1 color sensor problem	1. Check color sensor status 2. Check wires 3. Check power ON, OFF 4. Replace color sensor
Er.52		#No. 2 color sensor problem	
Er.53		#No. 3 color sensor problem	
Er.54		#No. 4 color sensor problem	
Er.61	SWITCH FOR BALL LANDING RECOGNITION	#1 Switch sensor for ball seating recognition motion problems	1. Check sensor input status 2. Check wires 3. Check power ON, OFF 4. Check solenoid operation status
Er.62		#2 Switch sensor for ball seating recognition motion problems	
Er.63		#3 Switch sensor for ball seating recognition motion problems	
Er.64		#4 Switch sensor for ball seating recognition motion problems	



Er.71	SOLENOID EXCEPTION HANDLING	#1 solenoid output operation problem	1. Check wires 2. Check power ON, OFF 3. Check solenoid operation status
Er.72		#2 solenoid output operation problem	
Er.73		#3 solenoid output operation problem	
Er.74		#4 solenoid output operation problem	
HELP	TICKET ERROR	No ticket	1. Check tickets 2. Check ticket motor 3. Check ticket sensor
※ The error code is displayed on the TICKET FND of the player with the error			

## 5-7. ERROR CODE HOW TO DETECT ERROR

ERROR CODE	ERROR TYPE	DESCRIPTION	HOW TO CHECK ERROR
Er.01	BY REGION	Location mismatch between setup save data and MAIN PCB DIP SW	Check setup save data and DIP SW location on MAIN PCB
Er.02	SYSTEM	Setup save data problem	Power on and check backup memory related to motherboard for setup
Er.03		Game save data problem	Power on and check backup memory for motherboard for games
Er.11	COIN ACCEPTOR	Player coin sensor signal still on	Signal on for more than 2 seconds
Er.13	BILL ACCEPTOR	Player bill sensor signal still on	Signal on for more than 2 seconds
Er.21	COLOR SENSOR COMMUNICATION	Color sensor communication problem	Check the color sensor communication signal every 5 seconds and detect if there is no signal for 1 minute. Error handling
Er.22		Color sensor protocol version incorrect	Between the main board and the color sensor IO board Protocol version does not match
Er.23	COLOR SENSOR IO	Color sensor IO board internal operation error	Color sensor IO board internal operation error
Er.31	MAIN(SHUFFLE) MOTOR	Encoder signal off or still on	Encodersensor signalon for more than 2 seconds during motor operation. (Error after 3 reverse rotation processing)
Er.41	SOLENOID	#1 Solenoid operation problem	1. Solenoid operates when there is a signal from the switch sensor for ball landing recognition before the game starts. 2. Even if the solenoid operates, if there is still a signal from the switch sensor for ball seating recognition, the solenoid operates again. 3. Repeated action 20 times 4. Error after 20 repetitions
Er.42		#2 Solenoid operation problem	
Er.43		#3 Solenoid operation problem	
Er.44		#4 Solenoid operation problem	
Er.45		Problem with the number of IR sensor balls recognized in each hole during game play	1. After the game starts, the hole check count increases as the ball enters each game hole 2. After the game is over, there are balls in each game hole. Error processing if the number of holes that is not recognized at least one is 13 or more
Er.51	COLOR SENSOR	#No. 1 color sensor problem	1. Error code received from color sensor board for no color sensor measurement data 2. Error after 5 or more attempts
Er.52		#No. 2 color sensor problem	
Er.53		#No. 3 color sensor problem	
Er.54		#No. 4 color sensor problem	
Er.61	SWITCH FOR BALL LANDING RECOGNITION	#1 Switch sensor for ball seating recognition motion problems	For 5 gameplays No signal from ball seating switch sensor
Er.62		#2 Switch sensor for ball seating recognition motion problems	
Er.63		#3 Switch sensor for ball seating recognition motion problems	
Er.64		#4 Switch sensor for ball seating recognition motion problems	

Er.71	SOLENOID EXCEPTION HANDLING	#1 solenoid output operation problem	1. If the operation signal continues when the solenoid is stopped, the exception handling count is increased and the output port is stopped. 2. Exception handling count is 5 or more Error handling when it occurs
Er.72		#2 solenoid output operation problem	
Er.73		#3 solenoid output operation problem	
Er.74		#4 solenoid output operation problem	
HELP	TICKET ERROR	No ticket	1. Check tickets 2. Check ticket motor 3. Check ticket sensor
※ The error code is displayed on the TICKET FND of the player with the error			

## 6. MAINTENANCE

---

### 6-1. Precautions for turning on the power

: When it is newly turned on after power is turned off, the power must be turned on after 10 seconds.

### 6-2. When installing the device

: Connect the device with a ground outlet to which fg is connected.

### 6-3. Main board management

: Dust removal on the main board will be carried out once a month.

### 6-4. Basic product management : Clean it regularly

### 6-5. This product should only be used for indoor use

# 7. EXPLODE VIEW

## 7-1. MAIN CABINET PART

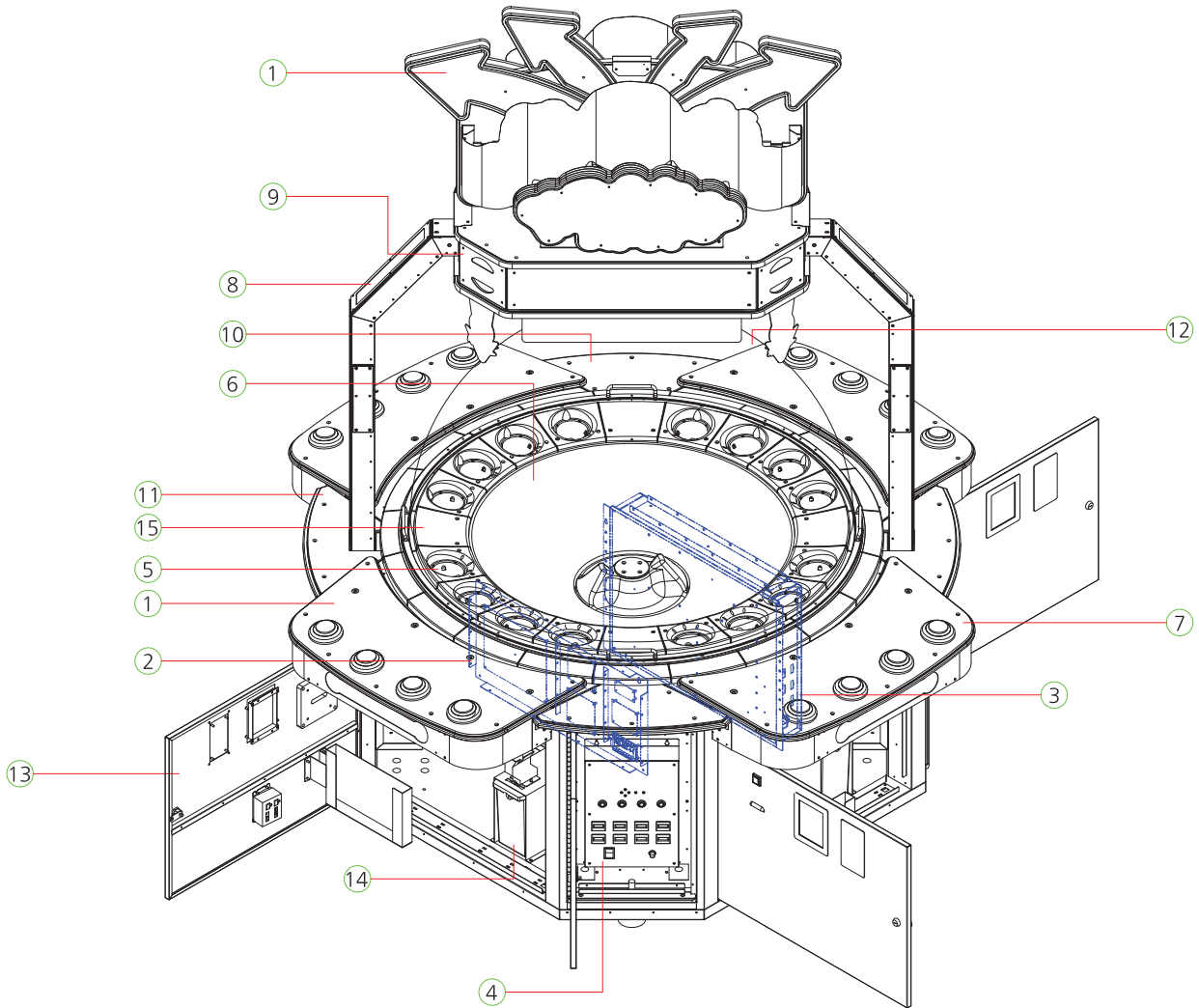

NO.	PART NAME	SPEC.	QUANTITY	CODE NO.
1	BILLBOARD PART	-	1	-
2	MAIN BOARD PART	-	1	-
3	POWER BOX PART	-	1	-
4	CONTROL PANEL PART	-	1	-
5	BALL PERCEIVE BASE PART	-	16	-
6	BALL ROTATE PART	-	1	-
7	BUTTON TABLE PART	-	4	-
8	SIDE FRAME PART	-	2	-
9	SPEAKER BOX PART	-	1	-
10	CORNER TABLE-A PART	-	2	-
11	CORNER TABLE-B PART	-	2	-
12	CABINET COVER DOME PART	-	1	-
13	CABINET DOOR PART	-	4	-
14	COIN BOX PART	-	4	-
15	BALL CUP BLANK MOLD	PC-3t	4	MKZB0PLA002

## 7-2. BILLBOARD PART

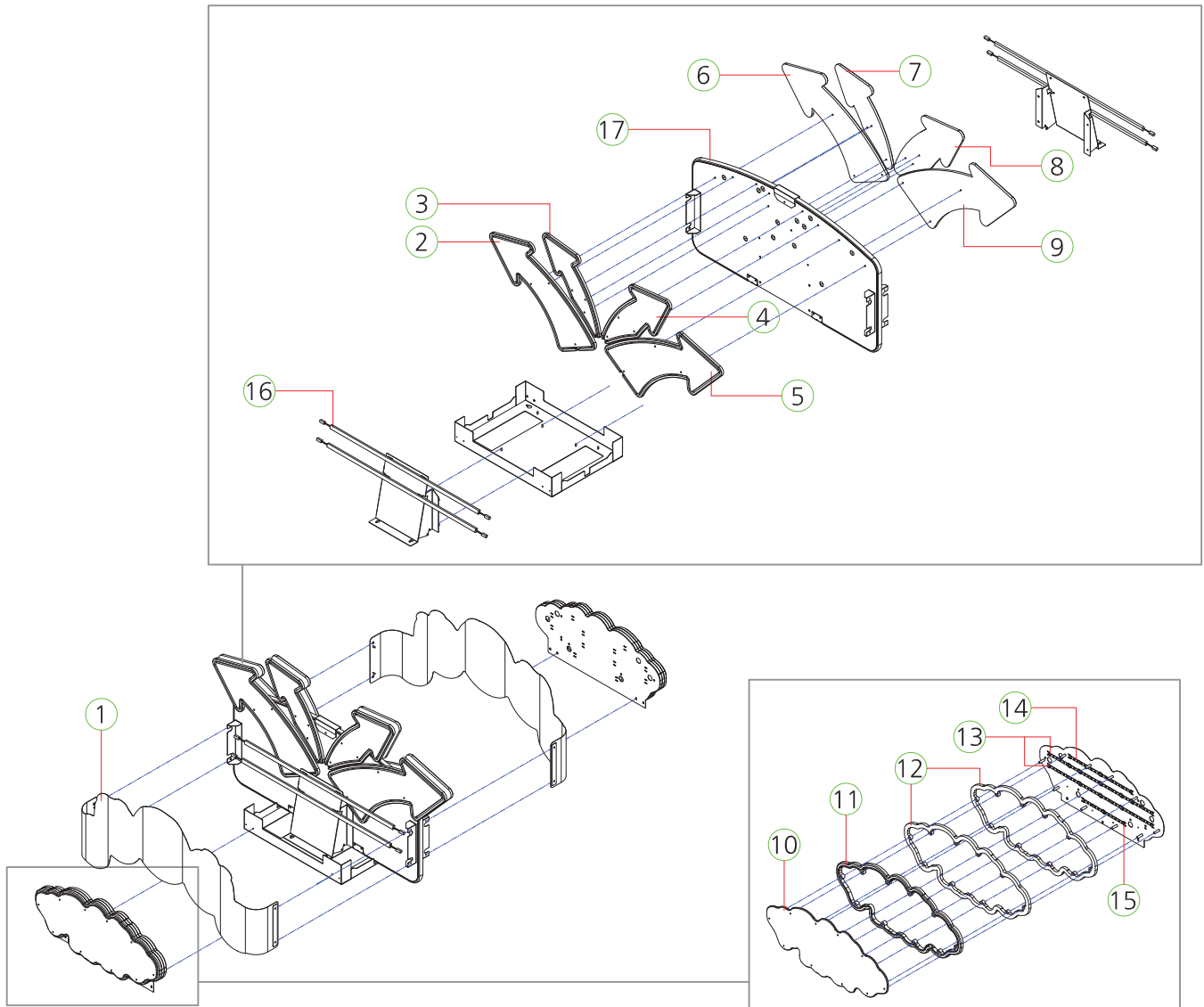

NO. 10~15 [\*Quantity per set]

NO.	PART NAME	SPEC.	QUANTITY	CODE NO.
1	BILLBOARD CHARACTER ACRYL	PET-0.8t	2	AKZB0ACP062
2	BILLBOARD ARROW ACRYL-A-L	FOMAX-10t	1	AKZB0ACP041
3	BILLBOARD ARROW ACRYL-B-L	FOMAX-10t	1	AKZB0ACP043
4	BILLBOARD ARROW ACRYL-C-L	FOMAX-10t	1	AKZB0ACP045
5	BILLBOARD ARROW ACRYL-D-L	FOMAX-5t	1	AKZB0ACP047
6	BILLBOARD ARROW ACRYL-A-R	FOMAX-10t	1	AKZB0ACP042
7	BILLBOARD ARROW ACRYL-B-R	FOMAX-10t	1	AKZB0ACP044
8	BILLBOARD ARROW ACRYL-C-R	FOMAX-10t	1	AKZB0ACP046
9	BILLBOARD ARROW ACRYL-D-R	FOMAX-10t	1	AKZB0ACP048
10	BILLBOARD LOGO CENTER COVER ACRYL	ACRYL-4.5t	1	AKZB0ACP049
11	BILLBOARD LOGO CENTER ACRYL	ACRYL-12t	1	MKZB0ACR001
12	BILLBOARD LOGO CENTER FOMAX	FOMAX-10t	2	MKZB0ACR002
13	FLEX_5050_WHITE_500_NWP_LR_30	30	2	MELE0LED027
14	FLEX_5050_WHITE_300_NWP_L_18	18	1	MELE0LED037
15	FLEX_5050_WHITE_250_NWP_LR_15	T5050 TOP300, 15	1	MELE0LED106
16	LED BAR 12V ASS'Y	LED BAR_710mm	4	AZZZ0PCB165
17	SILICON_1450_RED_L FLEXIBLE LED PCB	NEON(2835-100/M-12*6MM) 1CM/CUT	2	MELE0LED145
	SILICON_1030_GREEN_L FLEXIBLE LED PCB	NEON(2835-100/M-12*6MM) 1CM/CUT	2	MELE0LED146
	SILICON_1370_BLUE_L FLEXIBLE LED PCB	NEON(2835-100/M-12*6MM) 1CM/CUT	2	MELE0LED148
	SILICON_920_YELLOW_L FLEXIBLE LED PCB	NEON(2835-100/M-12*6MM) 1CM/CUT	2	MELE0LED147

### 7-3. MAIN BOARD PART

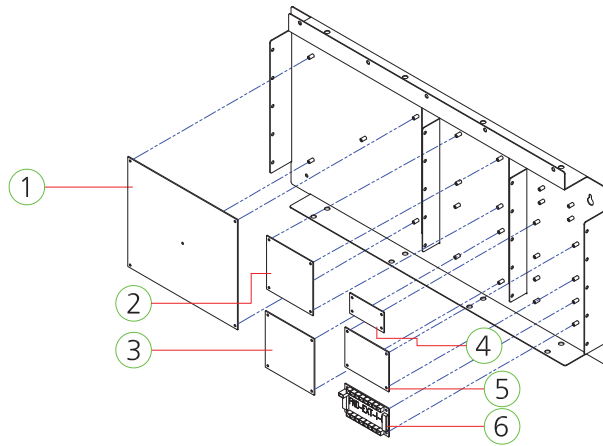

NO.	PART NAME	SPEC.	QUANTITY	CODE NO.
1	ANDA MAIN V1.6 PCB ASS'Y	WITH TOP SOUND	1	AZZZ0ASS084
2	F407_WS2813B_IO PCB ASS'Y	-	1	AZZZ0PCB234
3	SOUND PCB ASS'Y	-	1	AZZZ0PCB219
4	STANDARD CAN HUB PCB ASS'Y	-	1	AZZZ0PCB198
5	L6205 2CH_V2 PCB ASS'Y	DC MOTOR DRIVER_V2	1	AZZZ0PCB231
6	FND-EXT-IO-PCB ASS'Y	90 X 50 16BIT EXT	1	ABSP0PCB005

### 7-4. POWER BOX PART

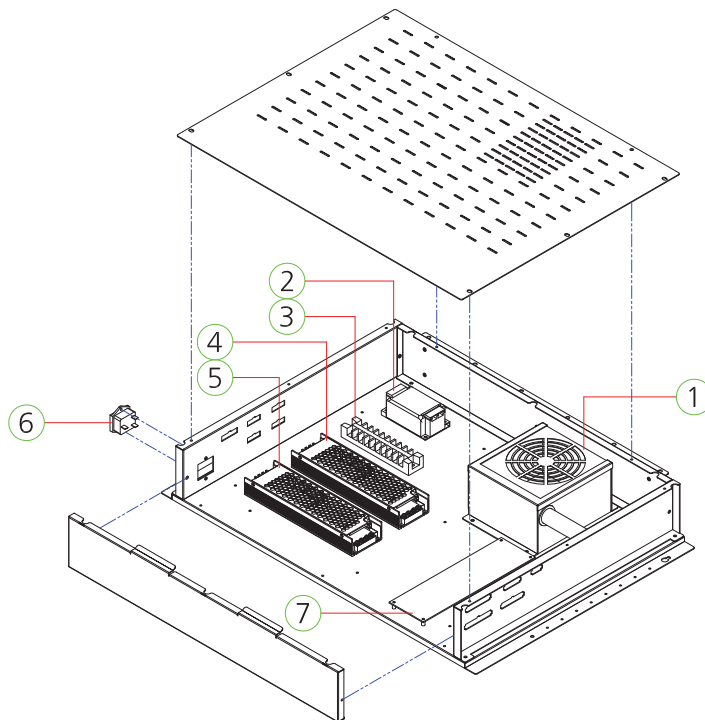

NO.	PART NAME	SPEC.	QUANTITY	CODE NO.
1	ATX POWER	FSP750-50AAA	1	MELE0SMP157
2	NOISE FILTER	TB1-10A0D0	1	MELE0NOI012
3	TERMINAL BLOCK	250V 10P UL_CE	1	MELE0TEB003
4	POWER SMPS	UHP-350-5V	1	MELE0SMP155
5	POWER SMPS	UHP-350-24V	1	MELE0SMP156
6	AC INPUT	DAC-13H	1	MELE0SWI015
7	ATX JOIN PCB ASS'Y	24PIN 2OZ PCB	1	AZZZ0PCB246

## 7-5. CONTROL PANEL PART

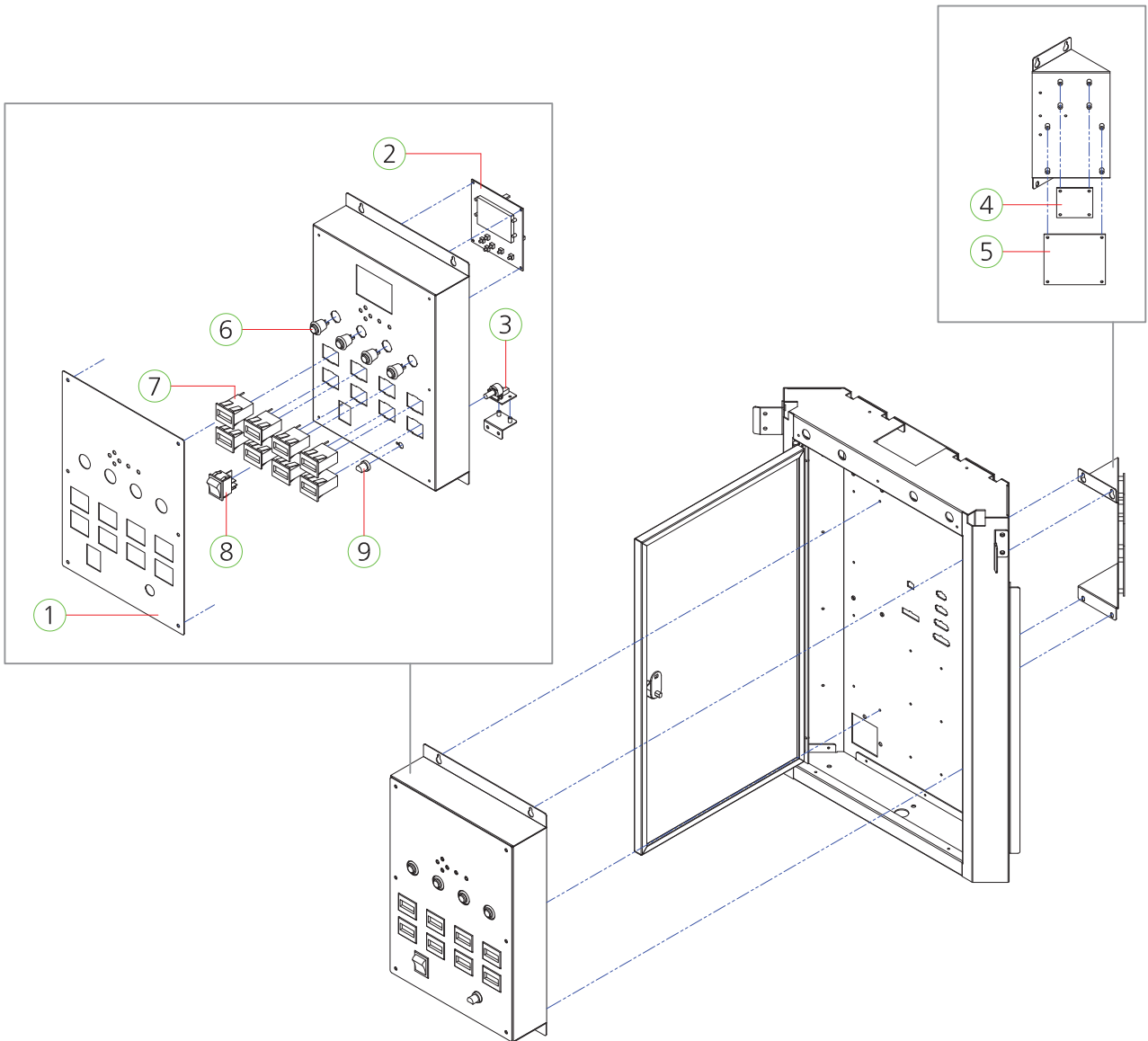

NO.	PART NAME	SPEC.	QUANTITY	CODE NO.
1	CABINET CONTROL PANEL COVER ACRYL	PET-1t	1	MKZB0ACR032
2	SETUP LCD PCB ASS'Y	-	1	AZZZ0PCB113
3	VOLUME PCB ASS'Y	1 VOLUME	1	AHM20PCB016
4	SOL FET 4CH PCB ASS'Y	12V_24V_4CH	1	AZZZ0PCB233
5	COLOR SENSOR IO PCB ASS'Y	COLOR SENSOR IO 4CH	1	AZZZ0PCB235
6	PUSH BUTTON SWITCH	DS-412R ROSH	4	MELE0PUS006
7	COUNTER	OA127CL W/2P CONNECTOR_20CM WIRE	8	MZZZ0COU002
8	ROCKER SWITCH	T-125 4P	1	MELE0SWI004
9	VOLUME KNOB	CAP BLUE	1	MELE0VOL007



## 7-6. BALL PERCEIVE BASE PART

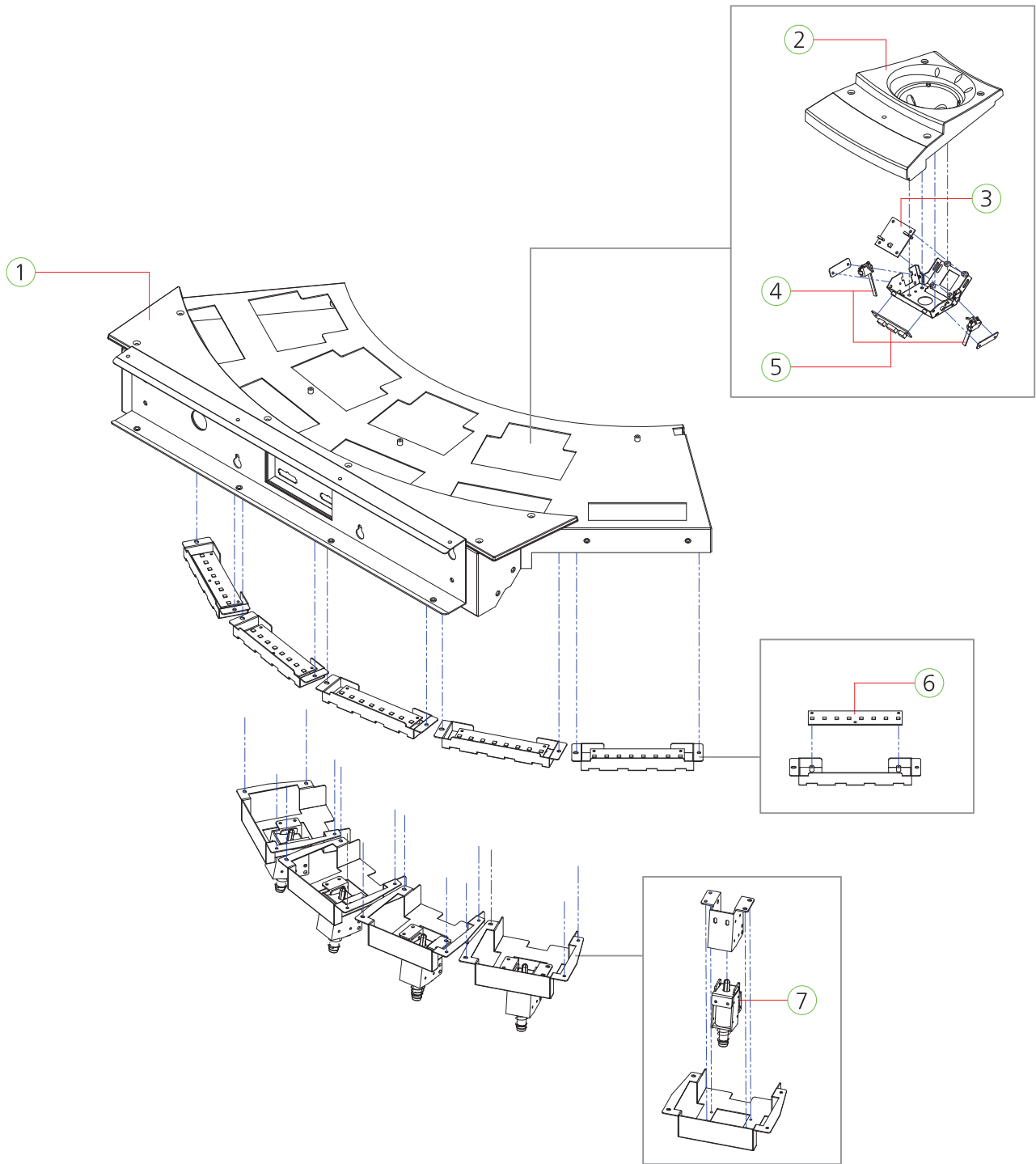

NO. 1~7 [\*Quantity per set]

NO.	PART NAME	SPEC.	QUANTITY	CODE NO.
1	CABINET BALL PERCEIVE BASE UPPER ACRYL_R	ACRYL-4.5t	1	AKZB0ACP054
	CABINET BALL PERCEIVE BASE UPPER ACRYL_G	ACRYL-4.5t	1	AKZB0ACP055
	CABINET BALL PERCEIVE BASE UPPER ACRYL_B	ACRYL-4.5t	1	AKZB0ACP056
	CABINET BALL PERCEIVE BASE UPPER ACRYL_Y	ACRYL-4.5t	1	AKZB0ACP057
2	BALL PERCEIVE MOLD	PC-3t	4	MKZB0PLA001
3	COLOR SENSOR PCB ASS'Y	-	4	AKZB0PCB001
4	PHOTO SENSOR	SG405CD_KODENSHI	8	MELE0PHO035
5	BALL SWITCH PCB ASS'Y	-	4	AKZB0PCB002
6	BALL PERCEIVE LED PCB ASS'Y	-	5	AJIE0PCB006
7	SOLENOID ASS'Y	DS12ES24V	4	AKZB0SOL001

## 7-7. BALL ROTATE PART

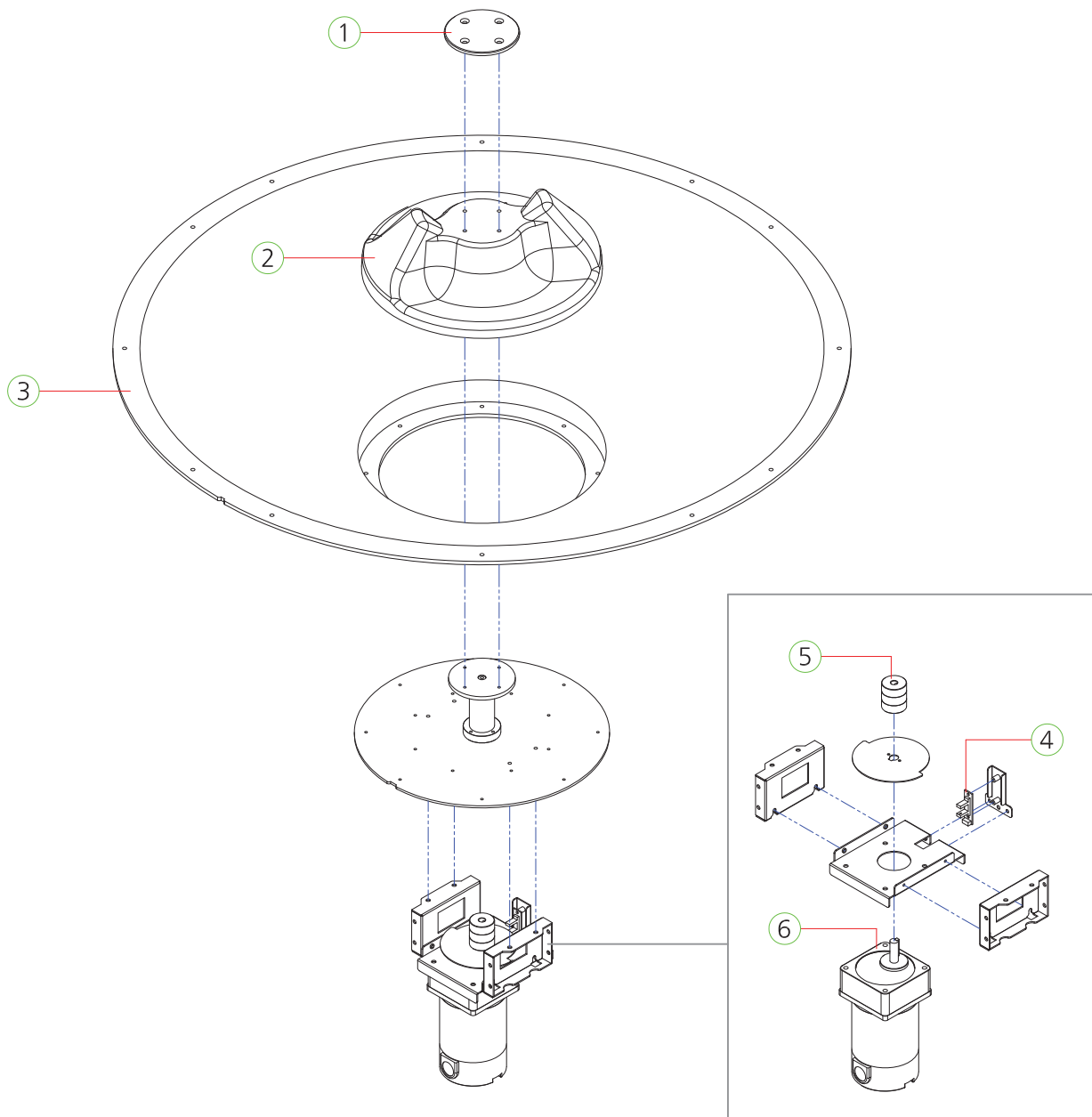

NO.	PART NAME	SPEC.	QUANTITY	CODE NO.
1	BALL ROTATE ACRYL	ACRYL-4.5t	1	AKZB0ACP040
2	BALL ROTATE MOLD	PC	1	MKZB0PLA003
3	CASE LOWER DOME	ABS VIOLET	1	MKZB0PLA005
4	PHOTO-INT1 PCB ASS'Y	ANGLE TYPE	1	AZZ0PCB103
5	COUPLING	JOC30	1	MZZ0COP014
6	MOTOR	K8D24V25W_K8G10C	1	MZZ0MOT182

## 7-8. BUTTON TABLE PART

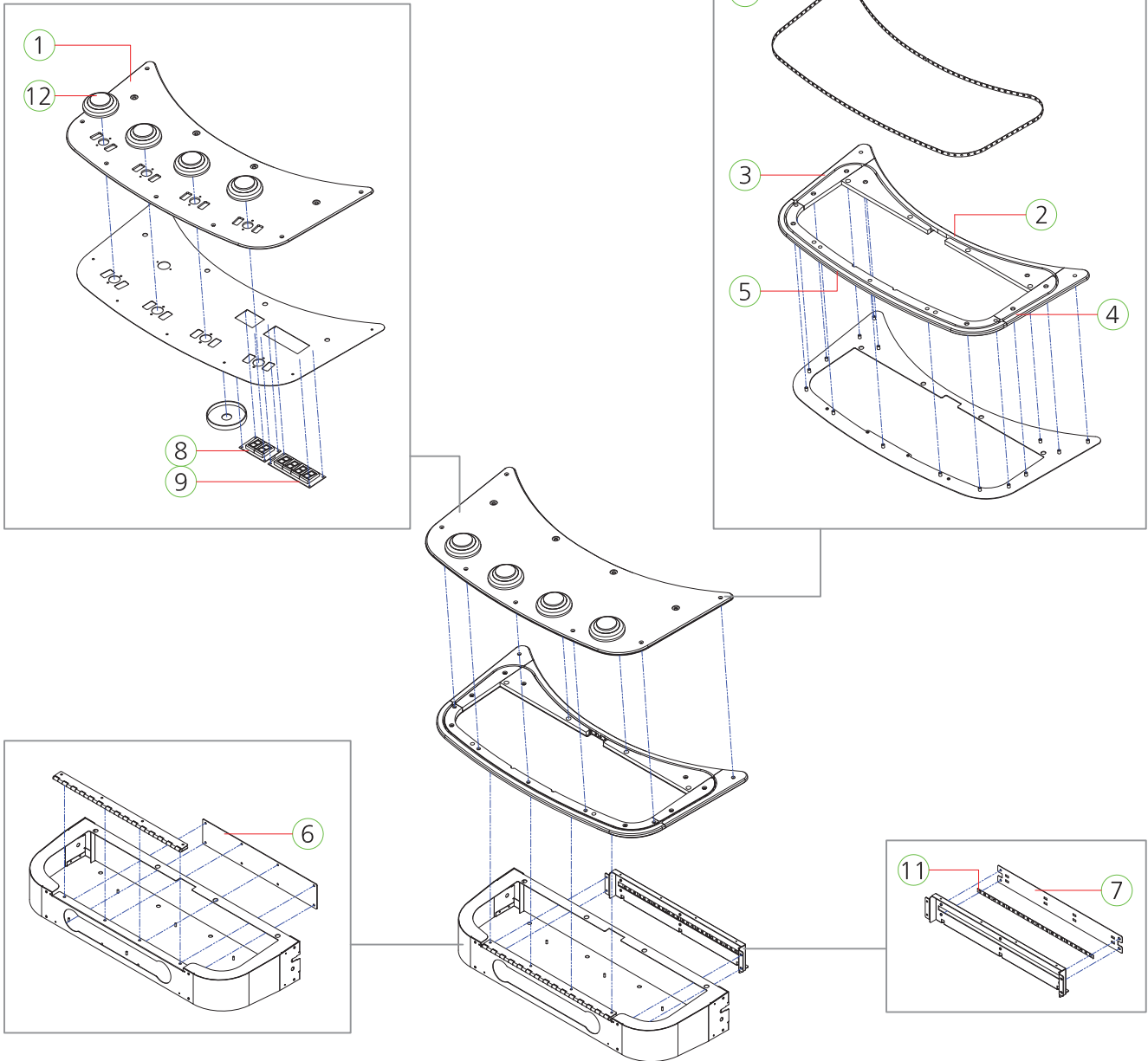

[\*Quantity per set]

NO.	PART NAME	SPEC.	QUANTITY	CODE NO.
1	BUTTON TABLE TOP COVER ACRYL_R	ACRYL-4.5t	1	AKZB0ACP050
	BUTTON TABLE TOP COVER ACRYL_G	ACRYL-4.5t	1	AKZB0ACP051
	BUTTON TABLE TOP COVER ACRYL_B	ACRYL-4.5t	1	AKZB0ACP052
	BUTTON TABLE TOP COVER ACRYL_Y	ACRYL-4.5t	1	AKZB0ACP053
2	BUTTON TABLE TOP BASE ACRYL-C	ACRYL-12t	1	MKZB0ACR007
3	BUTTON TABLE TOP BASE SIDE ACRYL-L	ACRYL-12t	1	MKZB0ACR005
4	BUTTON TABLE TOP BASE SIDE ACRYL-R	ACRYL-12t	1	MKZB0ACR006
5	BUTTON TABLE TOP BASE BOTTOM ACRYL	ACRYL-12t	1	MKZB0ACR004
6	BUTTON TABLE FRONT ACRYL_R	PET-1.5t	1	AKZB0ACP063
	BUTTON TABLE FRONT ACRYL_G	PET-1.5t	1	AKZB0ACP064
	BUTTON TABLE FRONT ACRYL_B	PET-1.5t	1	AKZB0ACP065
	BUTTON TABLE FRONT ACRYL_Y	PET-1.5t	1	AKZB0ACP066
7	BUTTON TABLE FRONT LED ACRYL	PET-1.0t	1	MKZB0ACR003
8	FND PCB ASS'Y	2941-2(STRAIGHT)	1	AFND0PCB003
9	FND PCB ASS'Y	2941-4(STRAIGHT)	1	AFND0PCB004
10	FLEX_WS2813_1859_112EA_LR	WS2813 V5 TOP300, 112	1	MELE0LED144
11	FLEX_WS2813B_400_NWP_LR_24	WS2813 V5 TOP300, 24	1	MELE0LED116
12	BUTTON ASS'Y	CL-2020 65 WITH LED	4	AZZZ0BUT009

## 7-9. SIDE FRAME PART

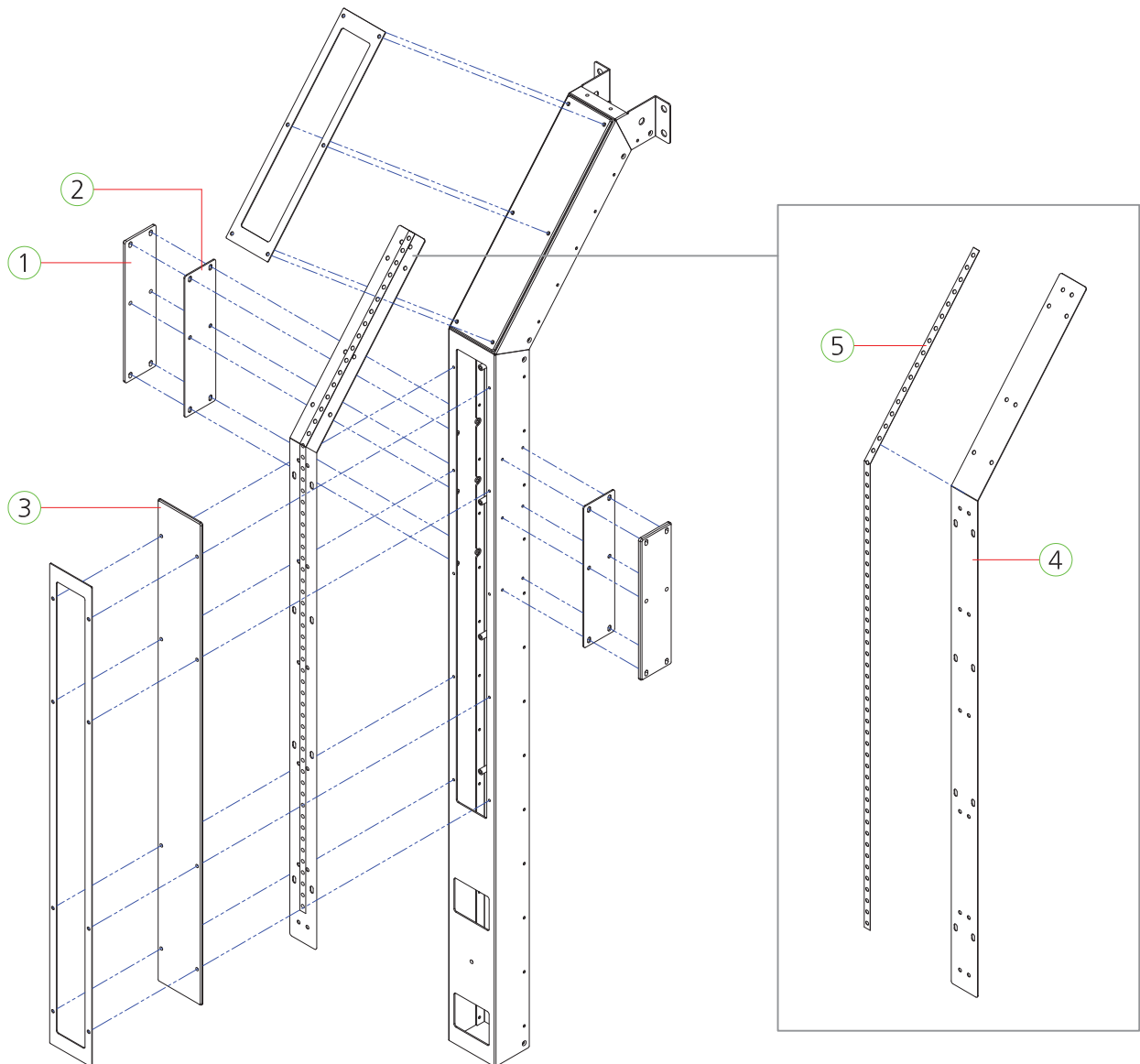

[\*Quantity per set]

NO.	PART NAME	SPEC.	QUANTITY	CODE NO.
1	SIDE FRAME TICKET SCORE COVER ACRYL	ACRYL-4.5t	2	MKZB0ACR014
2	SIDE FRAME TICKET SCORE ACRYL_R_BLANK	PET-1.5t	2	AKZB0ACP074
	SIDE FRAME TICKET SCORE ACRYL_G_BLANK	PET-1.5t	2	AKZB0ACP075
	SIDE FRAME TICKET SCORE ACRYL_B_BLANK	PET-1.5t	2	AKZB0ACP076
	SIDE FRAME TICKET SCORE ACRYL_Y_BLANK	PET-1.5t	2	AKZB0ACP077
3	SIDE FRAME COVER ACRYL-B	PC-3.0t	1	MKZB0ACR012
4	SIDE FRAME LED ACRYL	PET-1.0t	1	MKZB0ACR013
5	FLEX_WS2813_962_58EA_LR	WS2813 V5 TOP300, 58	1	MELE0LED143

# 7-10. SPEAKER BOX PART

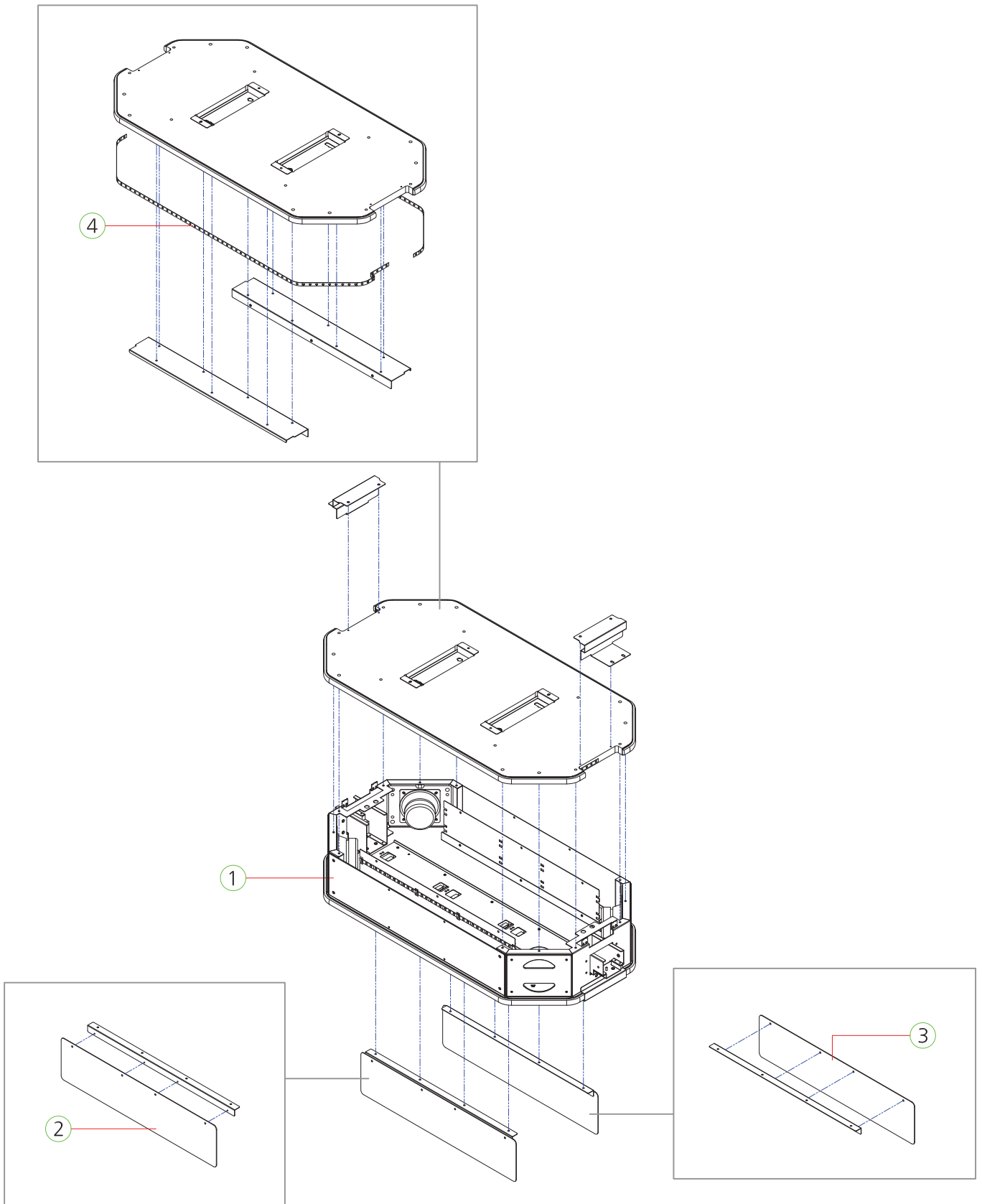

NO.	PART NAME	SPEC.	QUANTITY	CODE NO.
1	SPEAKER BOX BASE PLATE PART	-	1	-
2	SPEAKER BOX HOWTOPLAY ACRYL_L	-	1	AKZB0ACP073
3	SPEAKER BOX HOWTOPLAY ACRYL_R	-	1	AKZB0ACP073
4	FLEX_PINK_1150_NWP_L_20231006	T5050 300, 69	1	MELE0LED150

# 7-11. SPEAKER BOX BASE PART

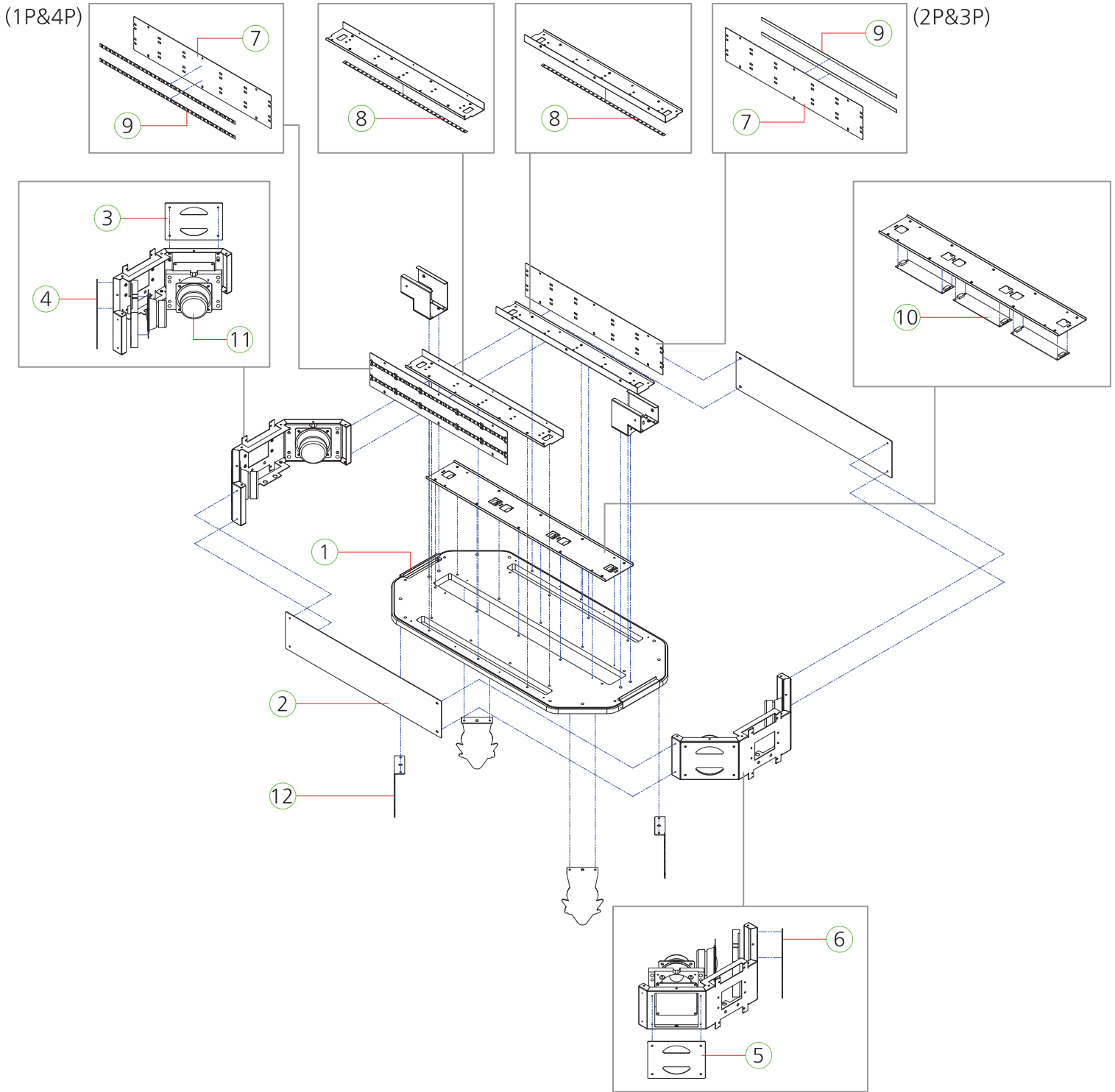

NO.	PART NAME	SPEC.	QUANTITY	CODE NO.
1	SPEAKER BOX BASE PLATE PART	-	1	-
2	SPEAKER BOX FRONT COVER ACRYL	PET-1.5t	2	AKZB0ACP072
3	SPEAKER COVER ACRYL_R	PET-1.5t	1	AKZB0ACP058
4	SPEAKER COVER ACRYL_Y	PET-1.5t	1	AKZB0ACP061
5	SPEAKER COVER ACRYL_G	PET-1.5t	1	AKZB0ACP059
6	SPEAKER COVER ACRYL_B	PET-1.5t	1	AKZB0ACP060
7	SPEAKER BOX FRONT LED ACRYL	PET-1.0t, CLEAR	2	MKZB0ACR016
8	FLEX_WHITE_500_NWP_LR	30	2	MELE0LED027
9	FLEX_WHITE_550_NWP_LR	T5050 TOP300, 33	4	MELE0LED112
10	NEW SPOT LED	ONE CHIP_WHITE	3	AZZZ0PCB191
11	SPEAKER	MID 4.5"+TW1/2" 8Ω	4	MZZZ0SPE021
12	BILLBOARD BOTTOM ARROW ACRYL	PET-2.0t	4	MKZB0ACR040

## 7-12. SPEAKER BOX BASE PLATE PART

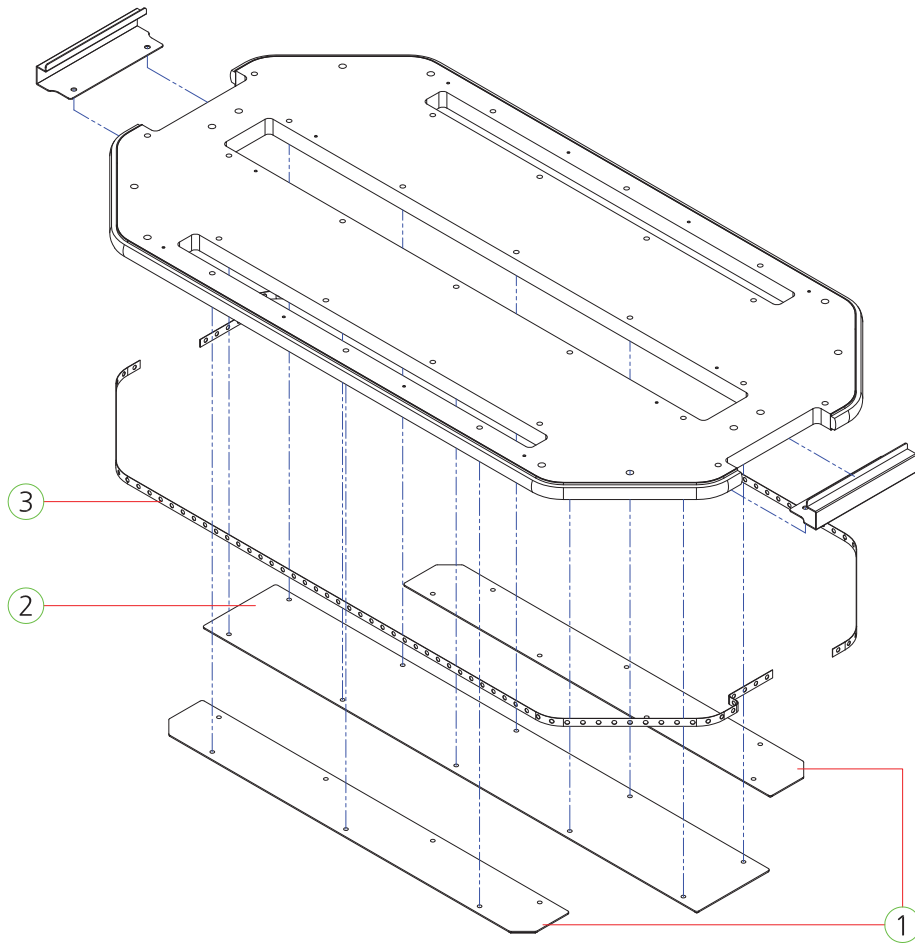

NO.	PART NAME	SPEC.	QUANTITY	CODE NO.
1	SPEAKER BOX BASE ACRYL	ACRYL-4.5t	2	MKZB0ACR017
2	SPEAKER BOX SPOT ACRYL	ACRYL-4.5t	1	MKZB0ACR015
3	FLEX_PINK_1150_NWP_L_20231006	T5050 300, 69	2	MELE0LED150



## 7-13. CORNER TABLE-A PART

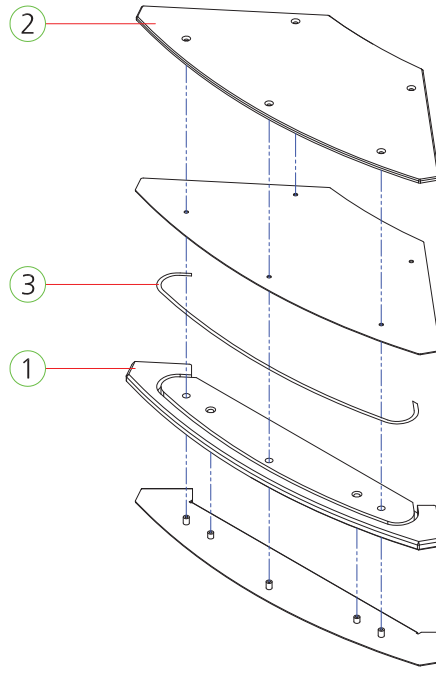

[\*Quantity per set]

NO.	PART NAME	SPEC.	QUANTITY	CODE NO.
1	CORNER TABLE BASE ACRYL	ACRYL-12t	1	MKZB0ACR010
2	CORNER TABLE TOP ACRYL-A_R	ACRYL-4.5t	1	MKZB0ACR033
3	FLEX_WS2813_450_27EA_LR	WS2813 V5 TOP300, 27	1	MELE0LED141

## 7-14. CORNER TABLE-B PART

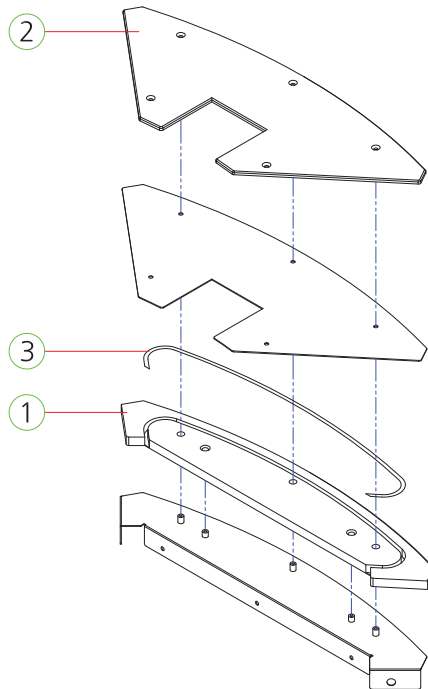

[\*Quantity per set]

NO.	PART NAME	SPEC.	QUANTITY	CODE NO.
1	CORNER TABLE BASE ACRYL	ACRYL-12t	1	MKZB0ACR010
2	CORNER TABLE TOP ACRYL-B_G	ACRYL-4.5t	1	MKZB0ACR034
3	FLEX_WS2813_450_27EA_LR	WS2813 V5 TOP300, 27	1	MELE0LED141

# 7-15. CABINET COVER DOME PART

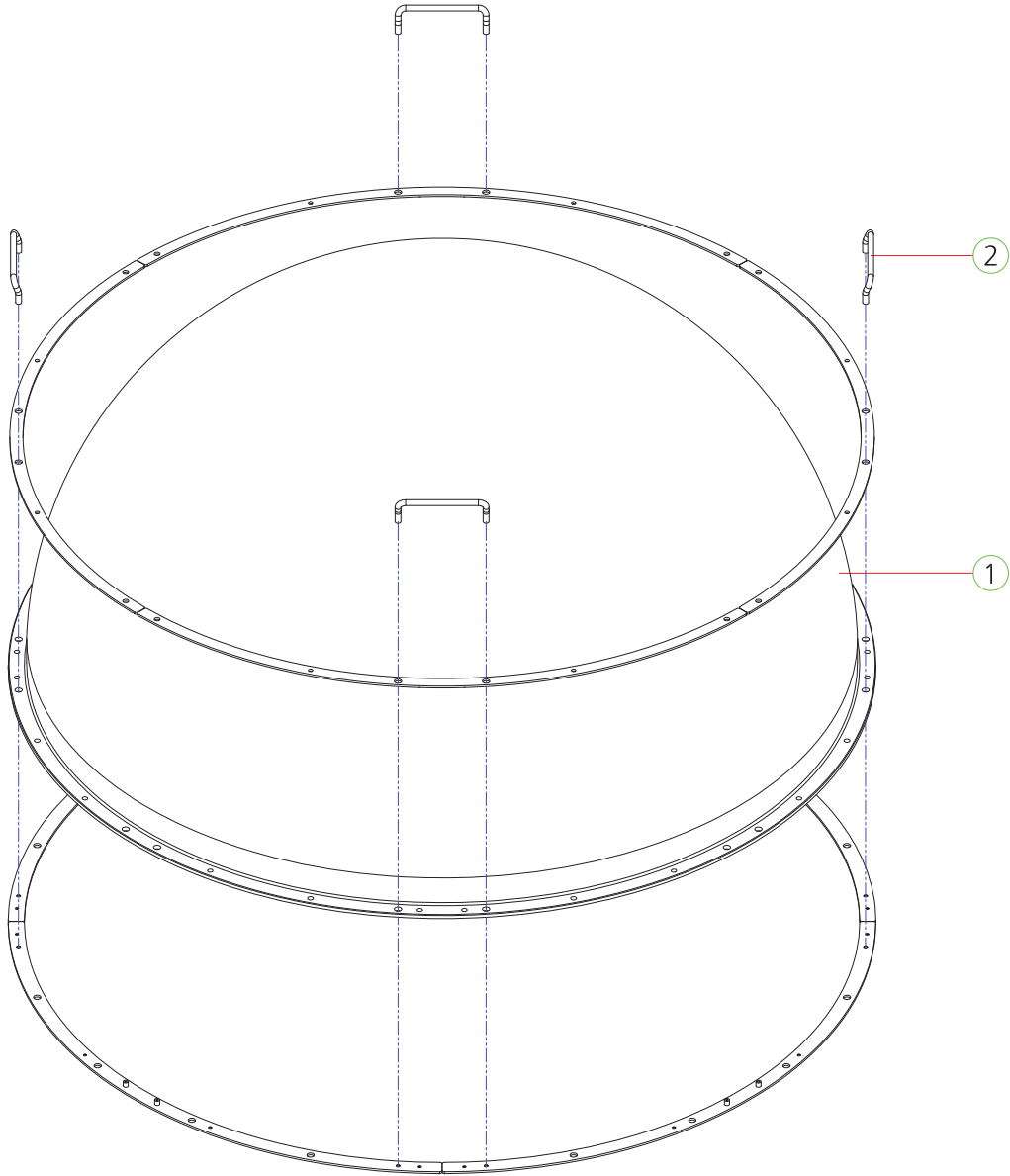

NO.	PART NAME	SPEC.	QUANTITY	CODE NO.
1	CASE COVER DOME	ACRYL 6t	1	MKZB0PLA004
2	ROUND BAR PULL	RBP-3-4(KA1232)	4	MZZZ0HAD001

## 7-16. CABINET DOOR PART

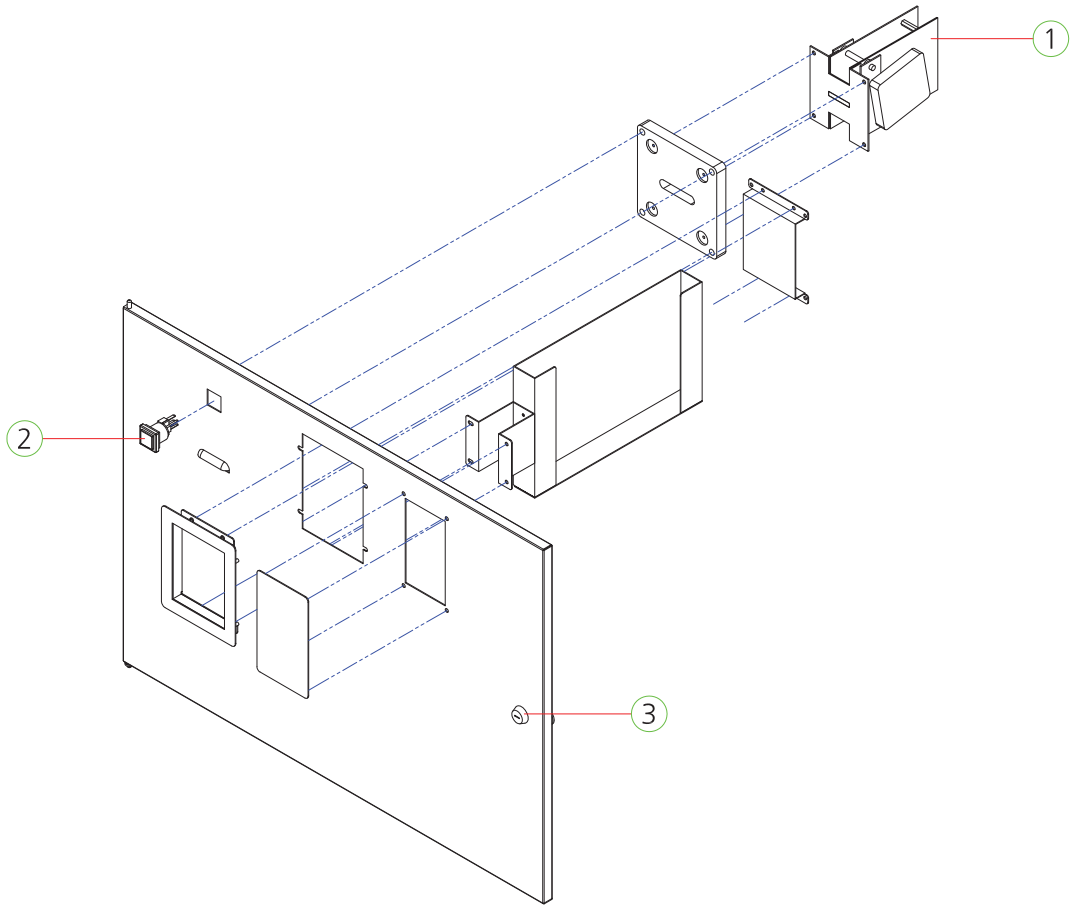

[\*Quantity per set]

NO.	PART NAME	SPEC.	QUANTITY	CODE NO.
1	[OPTION] TICKET DISPENSER	-	1	-
2	TICKET BUTTON SWITCH	TICKET AM1PB-26SH R12D	1	MMUM0BUT002
3	KEY ASS'Y	7001	1	MZZZ0KEY076

## 7-17. COIN BOX PART

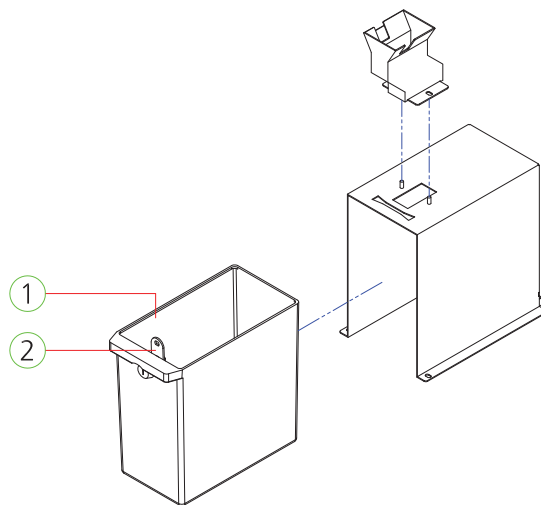

[\*Quantity per set]

NO.	PART NAME	SPEC.	QUANTITY	CODE NO.
1	COIN BOX SMALL	BLACK	1	MDRE0PLA007
2	KEY ASS'Y	6001	1	MZZZ0KEY075

## 8. SOLUTION

### \* ERROR CODES

CODE	ERROR	NOTE
Er.01	BY REGION	Location mismatch between setup save data and MAIN PCB DIP SW
Er.02	SYSTEM	Setup save data problem
Er.03		Game save data problem
Er.11	COIN ACCEPTOR	Player coin sensor signal still on
Er.13	BILL ACCEPTOR	Player bill sensor signal still on
Er.21	COLOR SENSOR COMMUNICATION	Color sensor communication problem
Er.22		Color sensor protocol version incorrect
Er.23	COLOR SENSOR IO	Color sensor IO board internal error
Er.31	MAIN(SHUFFLE) MOTOR	Encoder signal off or still on
Er.41	SOLENOID	#1 Solenoid operation problem
Er.42		#2 Solenoid operation problem
Er.43		#3 Solenoid operation problem
Er.44		#4 Solenoid operation problem
Er.45		Problem with the number of IR sensor balls recognized in each hole during game play
Er.51	COLOR SENSOR	#No. 1 color sensor problem
Er.52		#No. 2 color sensor problem
Er.53		#No. 3 color sensor problem
Er.54		#No. 4 color sensor problem
Er.61	SWITCH FOR BALL LANDING RECOGNITION	#1 Switch sensor for ball seating recognition motion problems
Er.62		#2 Switch sensor for ball seating recognition motion problems
Er.63		#3 Switch sensor for ball seating recognition motion problems
Er.64		#4 Switch sensor for ball seating recognition motion problems

Er.71	SOLENOID EXCEPTION HANDLING	#1 solenoid output operation problem
Er.72		#2 solenoid output operation problem
Er.73		#3 solenoid output operation problem
Er.74		#4 solenoid output operation problem
HELP	TICKET ERROR	No ticket

※ Reset button after taking actions

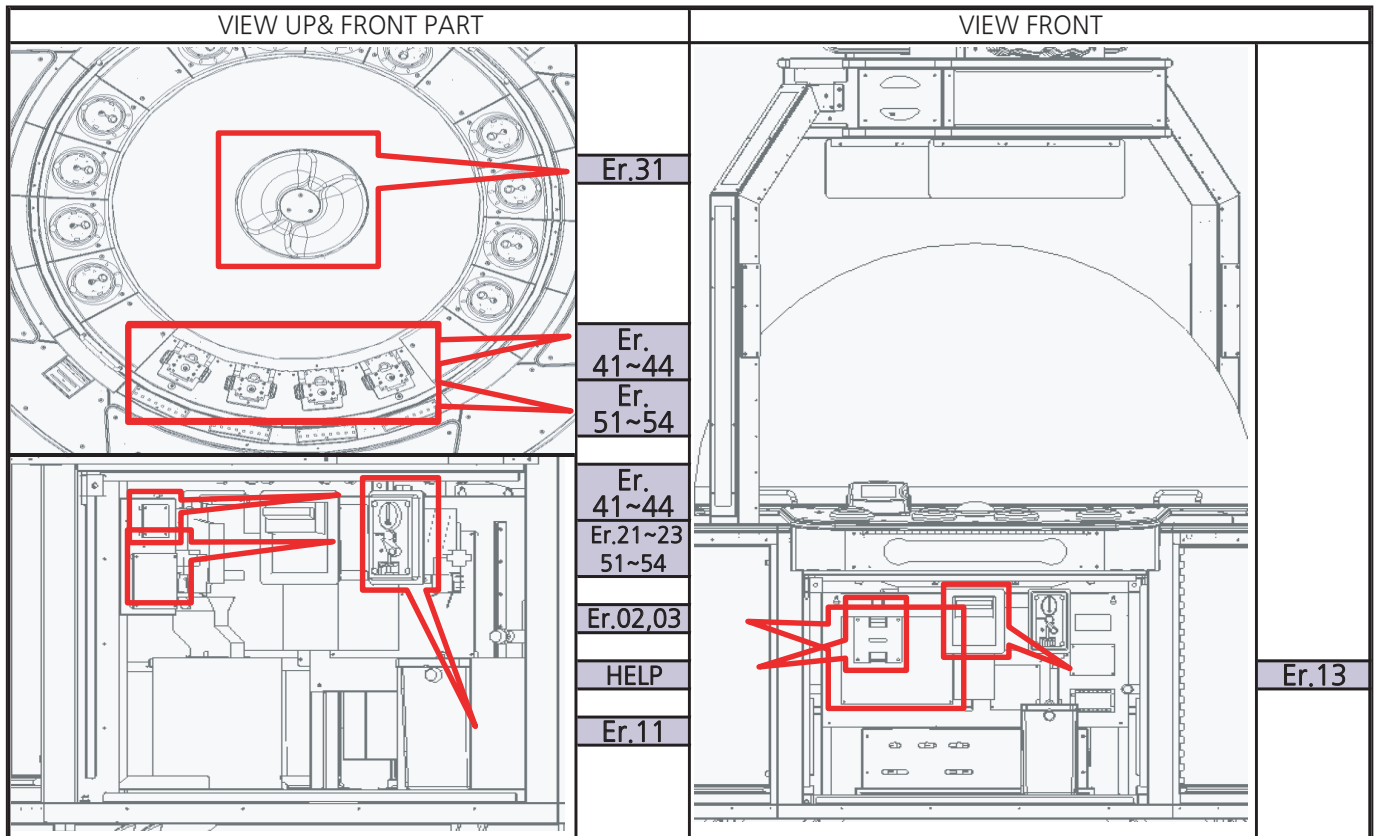

# 9. PCB CONNECTOR LOCATION

## \* PIN INFORMATION

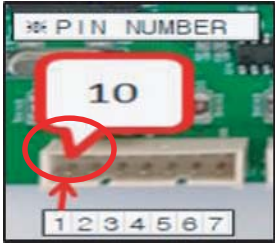
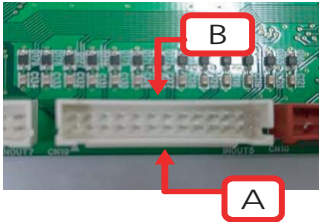
1	2	PIN DESCRIPTION
		<p>1. The arrow point means the contact pin number 1</p> <p>2. direction of Hirose connector</p>

### 9-1. MAIN PCB ASS'Y

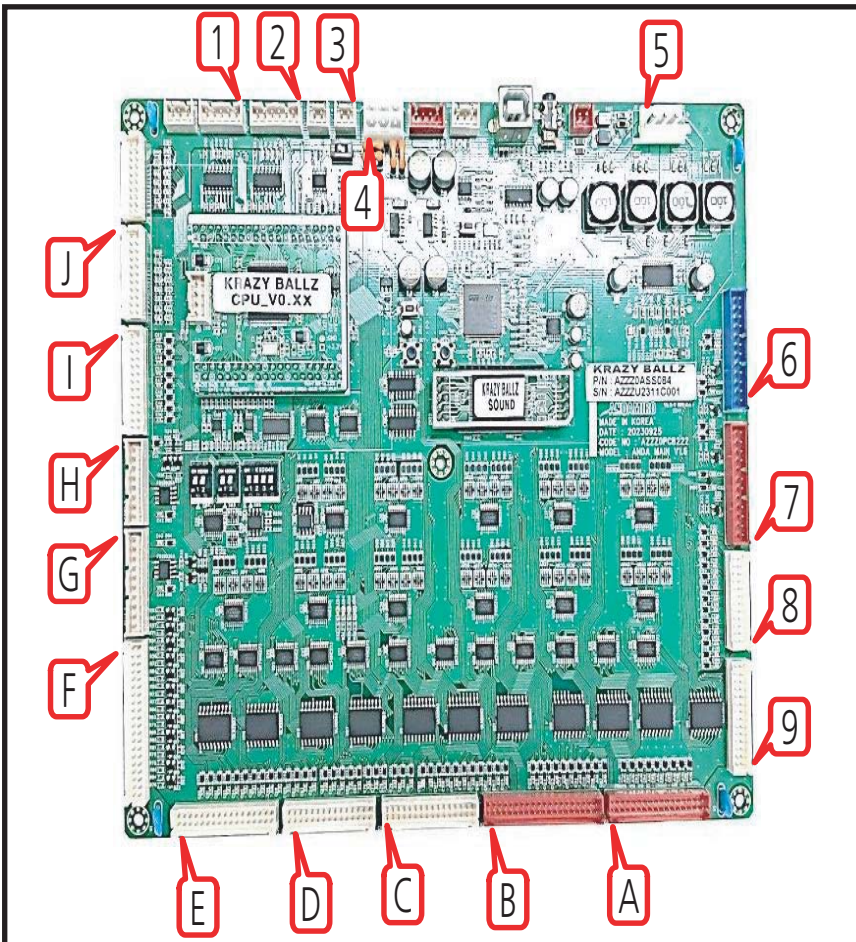
	<table border="1"> <thead> <tr> <th>NO</th> <th>FUNCTION</th> <th>LOC ATION</th> <th>PIN</th> </tr> </thead> <tbody> <tr> <td>1</td> <td>WS2813B IO PCB ASS'Y</td> <td>CN4</td> <td>5</td> </tr> <tr> <td>2</td> <td>SOUND PCB ASS'Y</td> <td>CN5</td> <td>6</td> </tr> <tr> <td>3</td> <td>CAN HUB PCB ASS'Y</td> <td>CN6</td> <td>2</td> </tr> <tr> <td>4</td> <td>MAIN POWER 5V,12V</td> <td>CN1</td> <td>6</td> </tr> <tr> <td>5</td> <td>1P,2P SPEAKER</td> <td>J6</td> <td>4</td> </tr> <tr> <td>6</td> <td>3P,4P TICKET &amp; BUTT</td> <td>CN11</td> <td>12</td> </tr> <tr> <td>7</td> <td>1P,2P TICKET &amp; BUTT</td> <td>CN10</td> <td>12</td> </tr> <tr> <td>8</td> <td>FINISH BUTTON &amp; LAMP</td> <td>CN19</td> <td>24</td> </tr> <tr> <td>9</td> <td>MOTOR PCB &amp; SENSOR</td> <td>CN21</td> <td>28</td> </tr> <tr> <td>A</td> <td>4P SENSOR(RX, TX), SOL PCB</td> <td>CN13</td> <td>34</td> </tr> <tr> <td>B</td> <td>1~3P IR SENSOR PCB (RX, TX), SOL PCB</td> <td>CN20</td> <td>40</td> </tr> <tr> <td>C</td> <td>3P,4P 1~4th BTN LAMP</td> <td>CN18</td> <td>32</td> </tr> <tr> <td>D</td> <td>1P,2P 1~4th BTN LAMP</td> <td>CN17</td> <td>30</td> </tr> <tr> <td>E</td> <td>BILL &amp; SERVICE BUT &amp; 3P,4P COUNTER</td> <td>CN16</td> <td>34</td> </tr> <tr> <td>F</td> <td>BUT LED, 2th,4th FND</td> <td>CN12</td> <td>40</td> </tr> <tr> <td>G</td> <td>3P,4P COIN SELECTOR</td> <td>J2</td> <td>10</td> </tr> <tr> <td>H</td> <td>1P,2P COIN SELECTOR</td> <td>J1</td> <td>8</td> </tr> <tr> <td>I</td> <td>SETUP &amp; 1,2P COUNTER &amp; VOLUME</td> <td>CN9</td> <td>26</td> </tr> <tr> <td>J</td> <td>FND EXT IO PCB</td> <td>CN15</td> <td>22</td> </tr> </tbody> </table>	NO	FUNCTION	LOC ATION	PIN	1	WS2813B IO PCB ASS'Y	CN4	5	2	SOUND PCB ASS'Y	CN5	6	3	CAN HUB PCB ASS'Y	CN6	2	4	MAIN POWER 5V,12V	CN1	6	5	1P,2P SPEAKER	J6	4	6	3P,4P TICKET & BUTT	CN11	12	7	1P,2P TICKET & BUTT	CN10	12	8	FINISH BUTTON & LAMP	CN19	24	9	MOTOR PCB & SENSOR	CN21	28	A	4P SENSOR(RX, TX), SOL PCB	CN13	34	B	1~3P IR SENSOR PCB (RX, TX), SOL PCB	CN20	40	C	3P,4P 1~4th BTN LAMP	CN18	32	D	1P,2P 1~4th BTN LAMP	CN17	30	E	BILL & SERVICE BUT & 3P,4P COUNTER	CN16	34	F	BUT LED, 2th,4th FND	CN12	40	G	3P,4P COIN SELECTOR	J2	10	H	1P,2P COIN SELECTOR	J1	8	I	SETUP & 1,2P COUNTER & VOLUME	CN9	26	J	FND EXT IO PCB	CN15	22
NO	FUNCTION	LOC ATION	PIN																																																																														
1	WS2813B IO PCB ASS'Y	CN4	5																																																																														
2	SOUND PCB ASS'Y	CN5	6																																																																														
3	CAN HUB PCB ASS'Y	CN6	2																																																																														
4	MAIN POWER 5V,12V	CN1	6																																																																														
5	1P,2P SPEAKER	J6	4																																																																														
6	3P,4P TICKET & BUTT	CN11	12																																																																														
7	1P,2P TICKET & BUTT	CN10	12																																																																														
8	FINISH BUTTON & LAMP	CN19	24																																																																														
9	MOTOR PCB & SENSOR	CN21	28																																																																														
A	4P SENSOR(RX, TX), SOL PCB	CN13	34																																																																														
B	1~3P IR SENSOR PCB (RX, TX), SOL PCB	CN20	40																																																																														
C	3P,4P 1~4th BTN LAMP	CN18	32																																																																														
D	1P,2P 1~4th BTN LAMP	CN17	30																																																																														
E	BILL & SERVICE BUT & 3P,4P COUNTER	CN16	34																																																																														
F	BUT LED, 2th,4th FND	CN12	40																																																																														
G	3P,4P COIN SELECTOR	J2	10																																																																														
H	1P,2P COIN SELECTOR	J1	8																																																																														
I	SETUP & 1,2P COUNTER & VOLUME	CN9	26																																																																														
J	FND EXT IO PCB	CN15	22																																																																														



### 9-2. F407\_WS2813B IO PCB ASS'Y

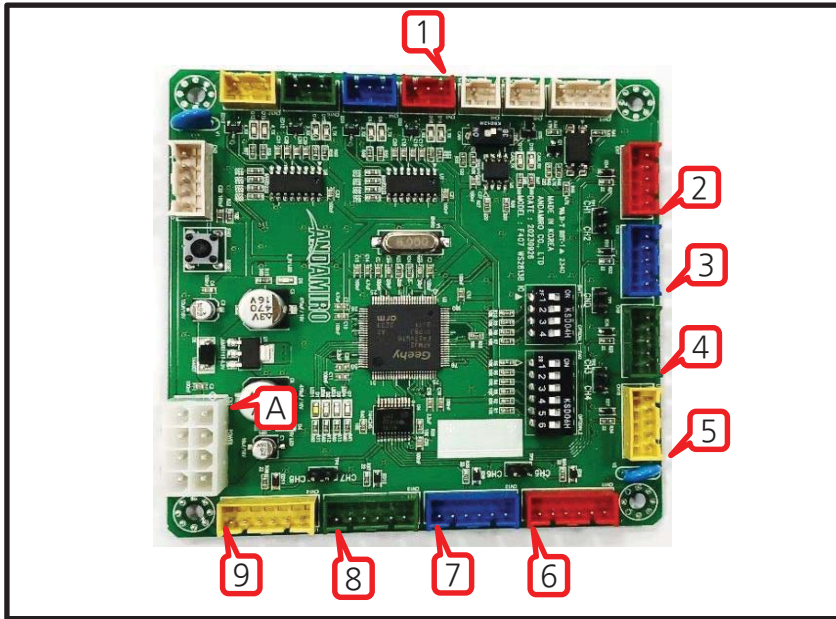

NO	FUNCTION	LOC ATION	PIN
1	MAIN PCB	CN3	3
2	1P TARGET & TABLE LED	CN7	5
3	2P TARGET & TABLE LED	CN8	5
4	3P TARGET & TABLE LED	CN9	5
5	4P TARGET & TABLE LED	CN10	5
6	1P SIDE TOP & BOTTOM	CN11	6
7	2P SIDE TOP & BOTTOM & PILLAR LED	CN12	6
8	3P SIDE TOP & BOTTOM	CN13	6
9	4P SIDE TOP & BOTTOM & PILLAR LED	CN14	6
A	IO POWER 5V	CN1	8

### 9-3. FND EXT IO PCB ASS'Y

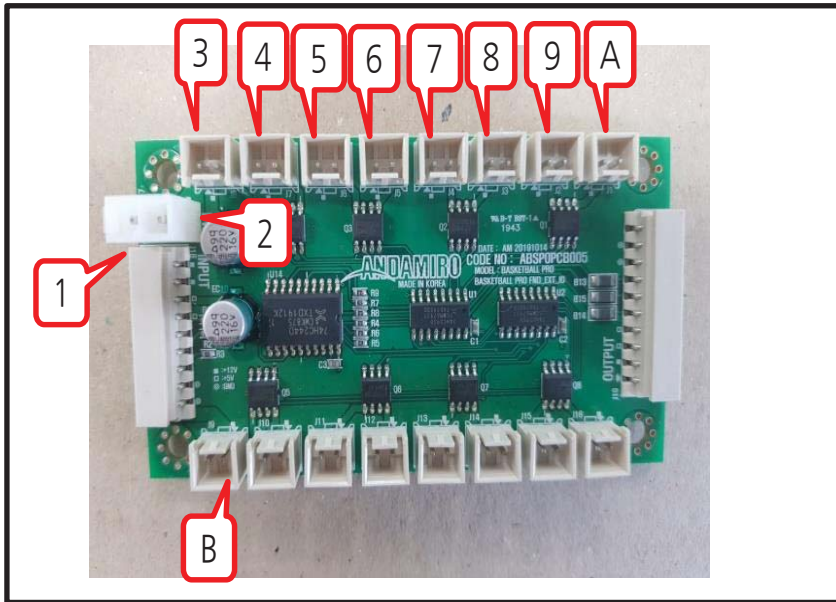

NO	FUNCTION	LOC ATION	PIN
1	MAIN PCB	CN3	9
2	FND EXT IO POWER 12V	J17	2
3	BILLBOARD SUPER BONUS(REAR)	J8	2
4	BILLBOARD CHARACTER BAR(REAR)	J7	2
5	BILLBOARD TITLE CENTER(REAR)	J6	2
6	BILLBOARD HOW TO PLAY(FRONT)	J5	2
7	BILLBOARD SUPER BONUS(FRONT)	J4	2
8	BILLBOARD CHARACTER BAR(FRONT)	J3	2
9	BILLBOARD TITLE CENTER(FRONT)	J2	2
A	BILLBOARD CELING SPOT	J1	2
B	BILLBOARD HOW TO PLAY(REAR)	J9	2

### 9-4. CAN HUB PCB ASS'Y

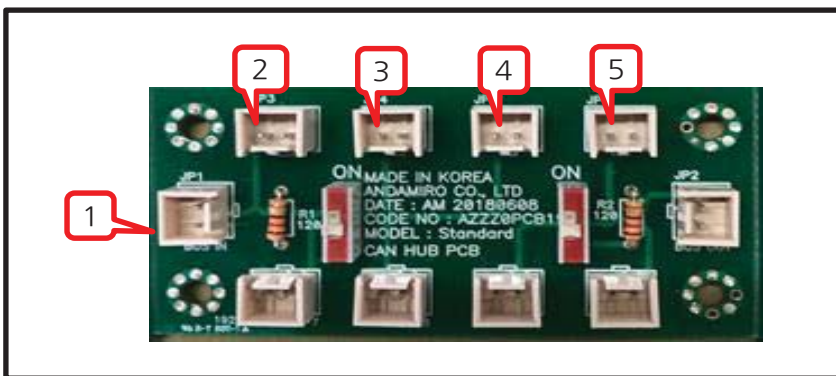

NO	FUNCTION	LOC ATION	PIN
1	MAIN PCB	JP1	2
2	1P COLOR SENSOR IO PCB	JP3	2
3	2P COLOR SENSOR IO PCB	JP4	2
4	3P COLOR SENSOR IO PCB	JP5	2
5	4P COLOR SENSOR IO PCB	JP6	2



### 9-5. COLOR SENSOR IO PCB ASS'Y

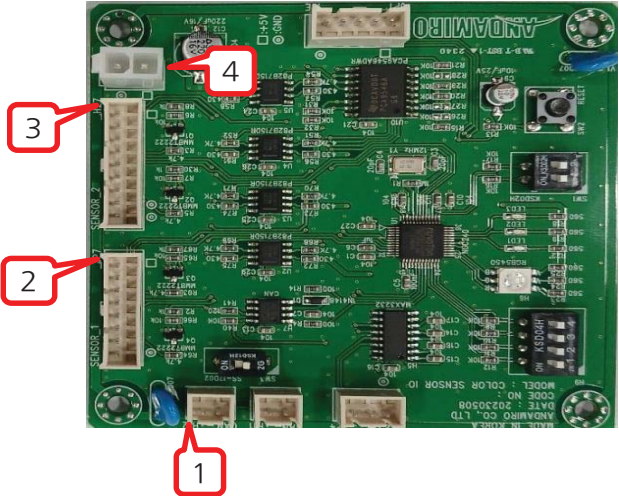

NO	FUNCTION	LOC ATION N	PIN
1	CAN HUB PCB ASS'Y	H12	2
2	COLOR SENSOR PCB 1,2	JP7	8
3	COLOR SENSOR PCB 3,4	H27	9
4	COLOR SENSOR POWER 5V	J1	2

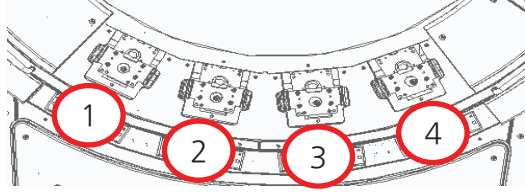

### 9-6. SOL FET 4CH PCB ASS'Y

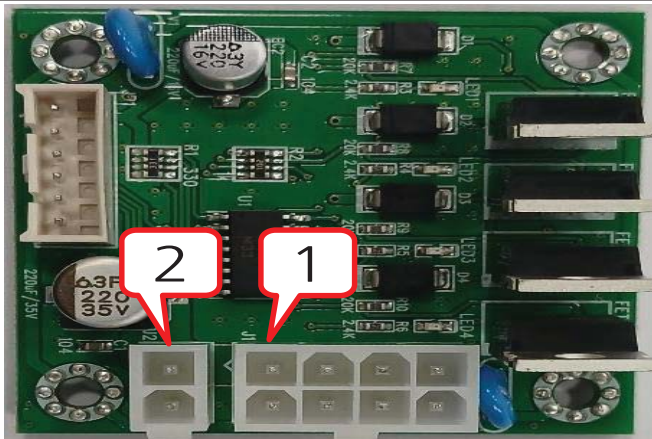

NO	FUNCTION	LOC ATION N	PIN
1	SOLENOID	J1	8
2	SOL PCB POWER 24V	J2	2
3	MAIN PCB	JP1	6

### 9-7. L6205 2CH\_V2 PCB ASS'Y

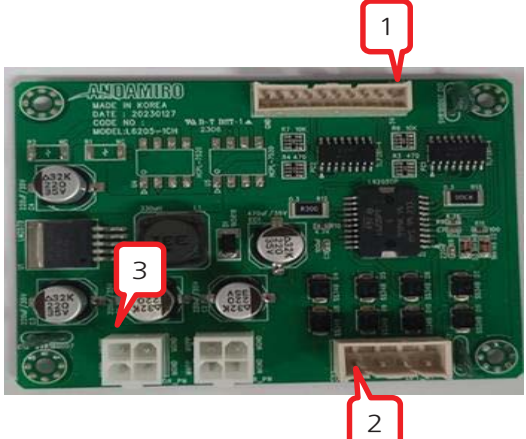

NO	FUNCTION	LOC ATION N	PIN
1	MAIN PCB	CON3	10
2	MAIN MOTOR	CON5	4
3	PCB POWER 24V	CON1	4

### 9-8. PHOTO INT-1 PCB ASS'Y



NO	FUNCTION	PIN
1	POWER 5V	1
2	ENABLE VOLTAGE	2
3	SENSOR OUT VOLTAGE	3
4	GND	4

### 9-9. COLOR SENSOR PCB ASS'Y



NO	FUNCTION	PIN
1	POWER 5V	1
2	-	2
3	B_I2C_SDA	3
4	B_I2C_SCL	4
5	WHITE LED ENABLE	5
6	GND	6

# POWER BOX Ass'y

# ATX POWER PCB 1/2

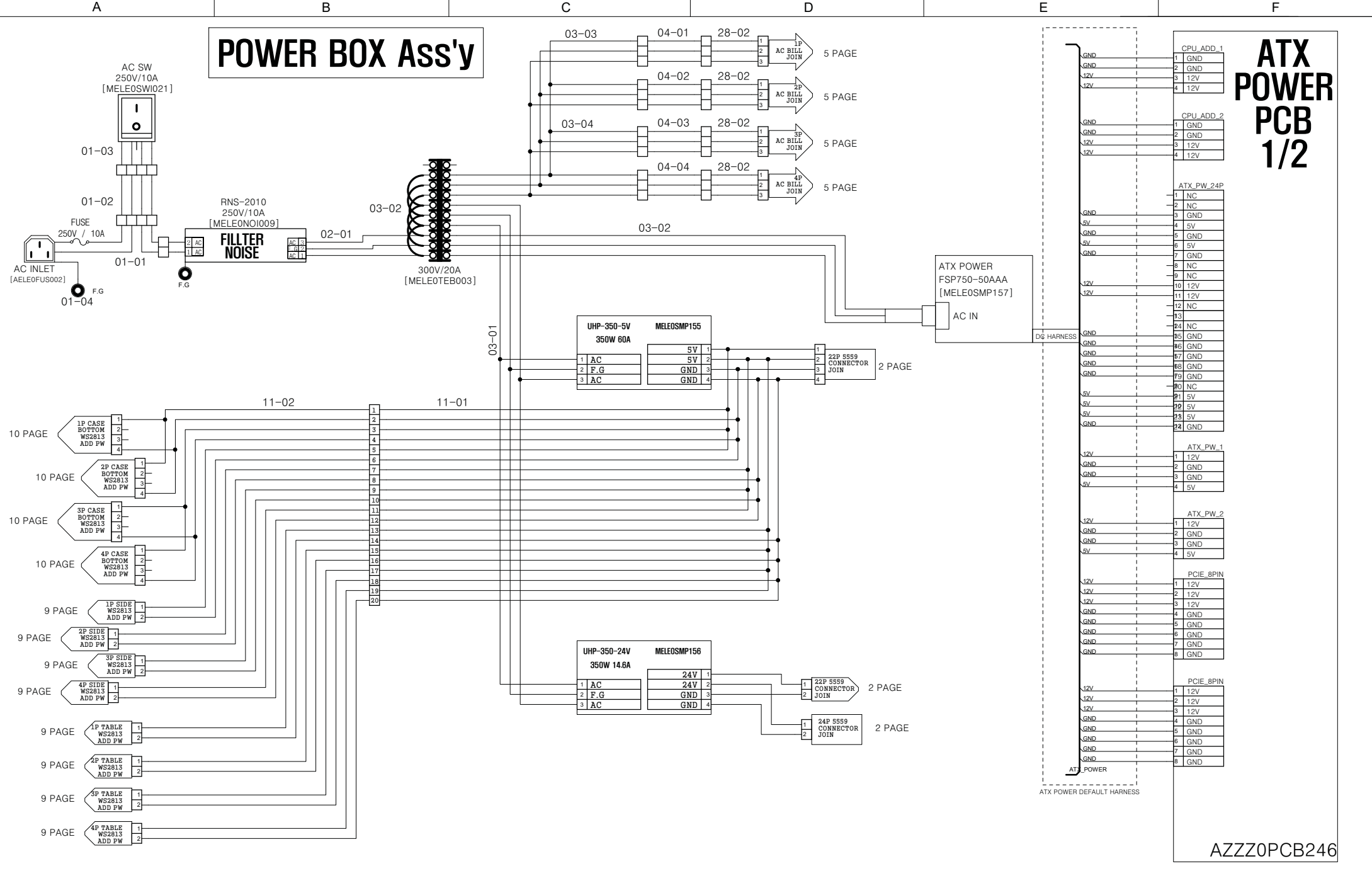

AZZZ0PCB246

REPRODUCTION, DISTRIBUTION AND UTILIZATION OF THIS DOCUMENT AS WELL AS COMMUNICATION OF ITS CONTENTS TO OTHERS WITHOUT EXPRESS AUTHORIZATION PROHIBITED. OFFENDERS WILL BE HELD LIABLE FOR THE PAYMENT OF DAMAGES.ALL RIGHT RESERVED. COPYRIGHT (c) ANDAMIRO  
 (복제, 배포 및 사용은 물론, 명시적 허가 없이는 타인에게 내용을 전달할 수 없으며 위반자는 손해 배상 책임을 집니다.)

DEPARTMENT	DRAWN BY	CHECKED BY	APPROVED BY	ITEM	<b>KRAZY BALLZ</b>
H/W				PAGE	1PAGE
				DATE	



# ATX POWER PCB 2/2

AZZZ0PCB246

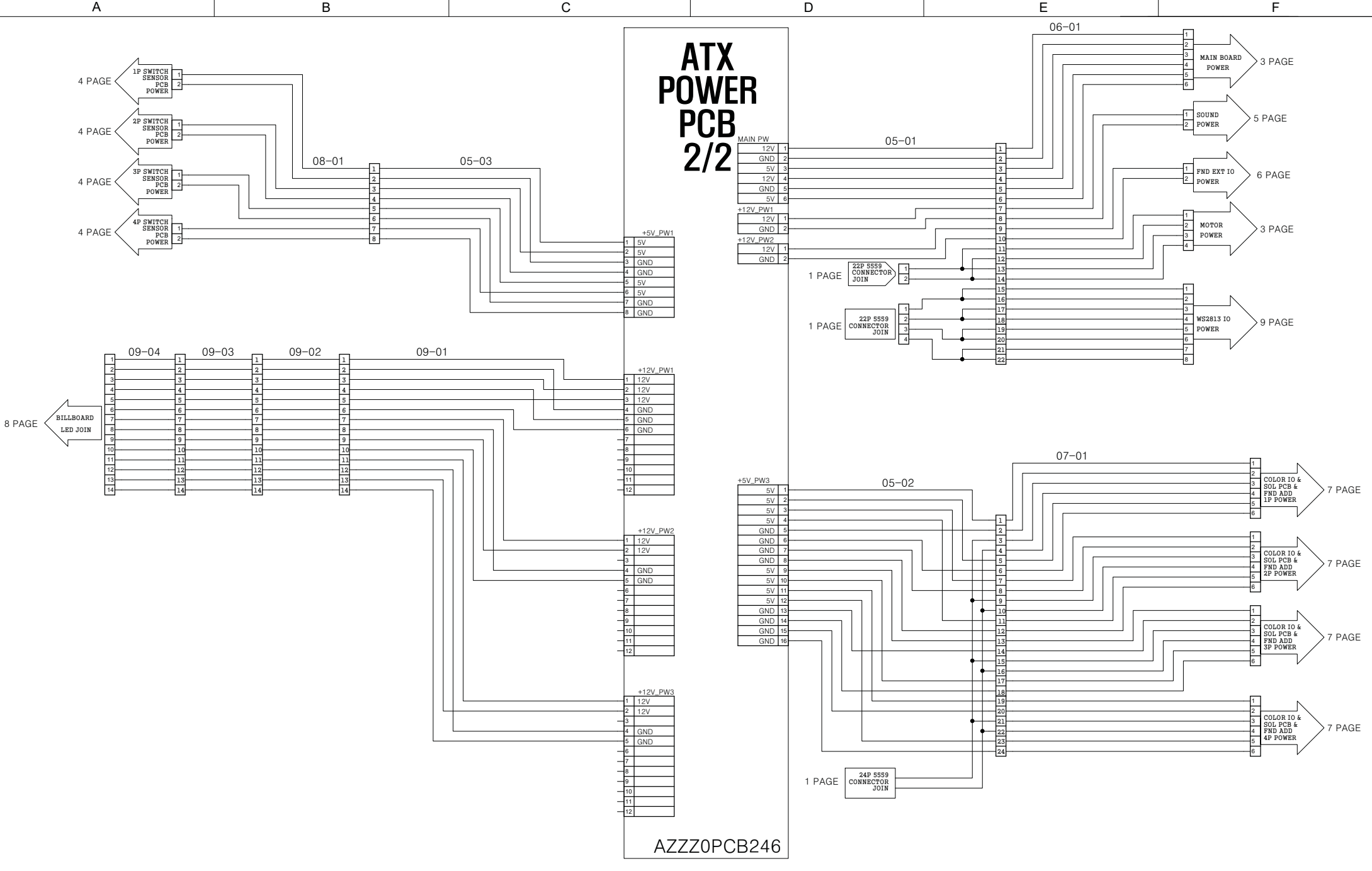

REPRODUCTION, DISTRIBUTION AND UTILIZATION OF THIS DOCUMENT AS WELL AS COMMUNICATION OF ITS CONTENTS TO OTHERS WITHOUT EXPRESS AUTHORIZATION PROHIBITED. OFFENDERS WILL BE HELD LIABLE FOR THE PAYMENT OF DAMAGES.ALL RIGHT RESERVED. COPYRIGHT (c) ANDAMIRO  
 (복제, 배포 및 사용은 물론, 명시적 허가 없이는 타인에게 내용을 전달할 수 없으며 위반자는 손해 배상 책임을 집니다.)

DEPARTMENT	DRAWN BY	CHECKED BY	APPROVED BY	ITEM	<b>KRAZY BALLZ</b>
H/W				PAGE	2PAGE
				DATE	



# SETUP BOX Ass'y

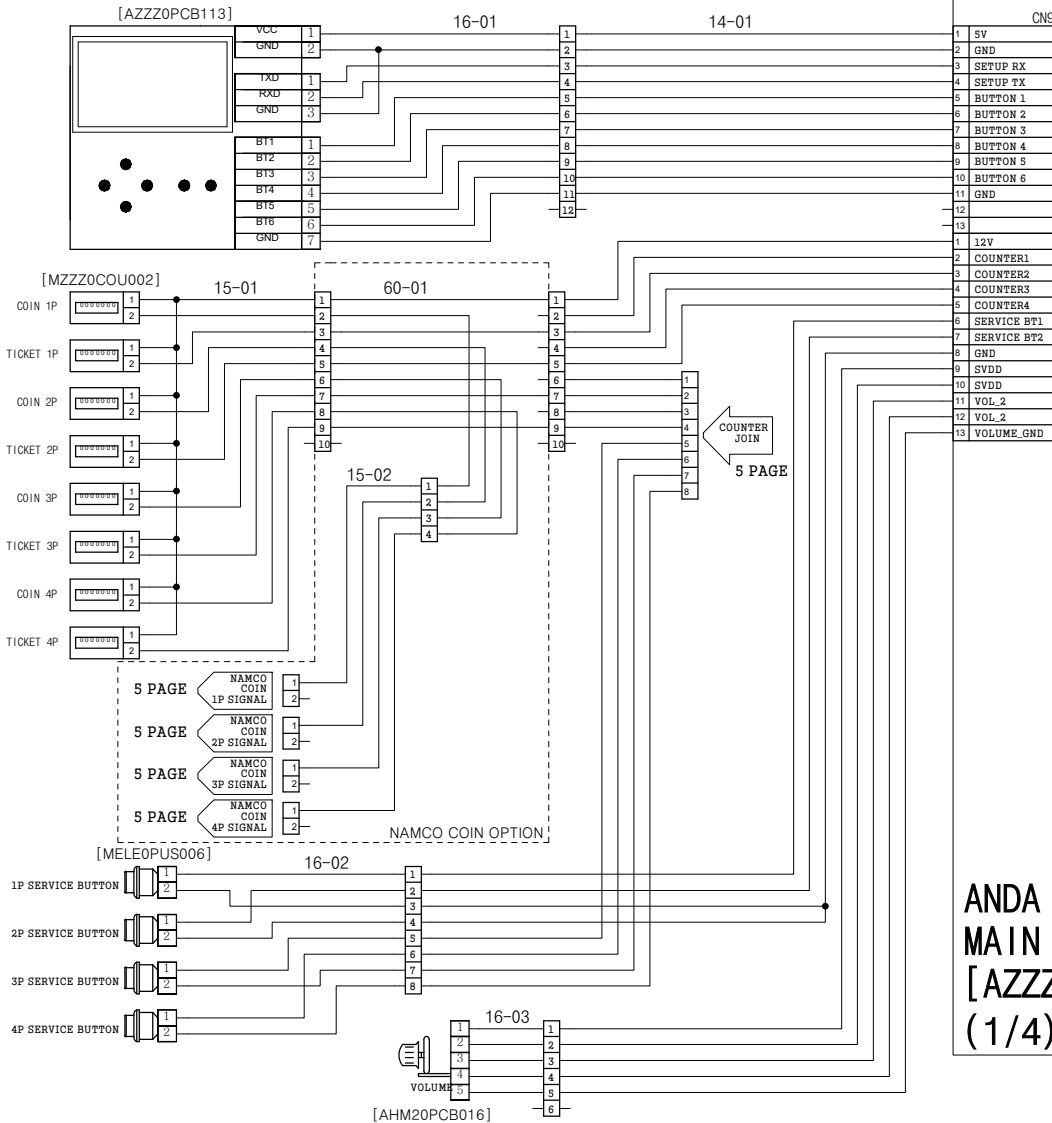

ANDA  
MAIN I/O  
[AZZZ0PCB232]  
(1/4)

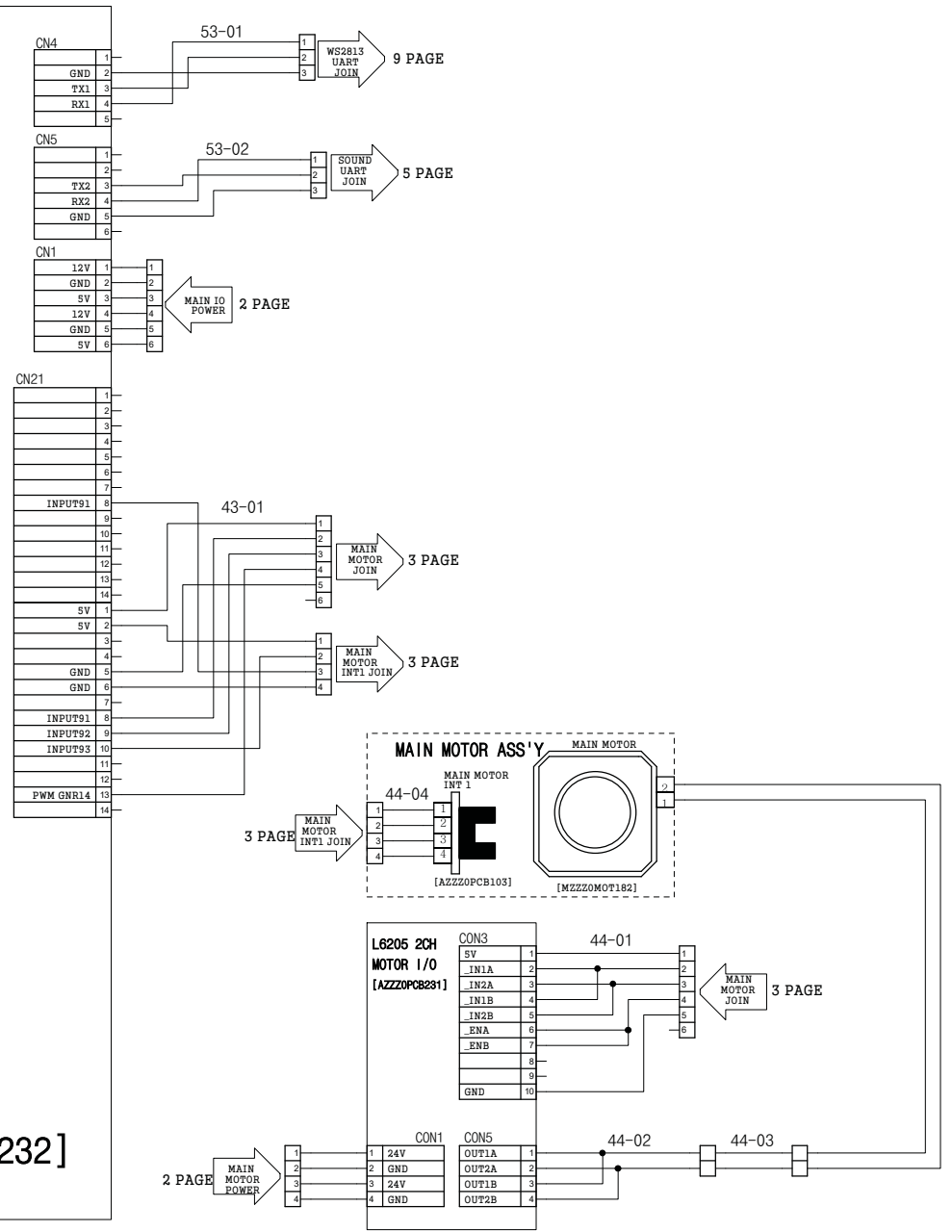

REPRODUCTION, DISTRIBUTION AND UTILIZATION OF THIS DOCUMENT AS WELL AS COMMUNICATION OF ITS CONTENTS TO OTHERS WITHOUT EXPRESS AUTHORIZATION PROHIBITED. OFFENDERS WILL BE HELD LIABLE FOR THE PAYMENT OF DAMAGES. ALL RIGHT RESERVED. COPYRIGHT (c) ANDAMIRO  
(복제, 배포 및 사용은 물론, 명시적 허가 없이는 타인에게 내용을 전달할 수 없으며 위반자는 손해 배상 책임을 집니다.)

DEPARTMENT	DRAWN BY	CHECKED BY	APPROVED BY	ITEM	<b>KRAZY BALLZ</b>
H/W				PAGE	3PAGE
				DATE	



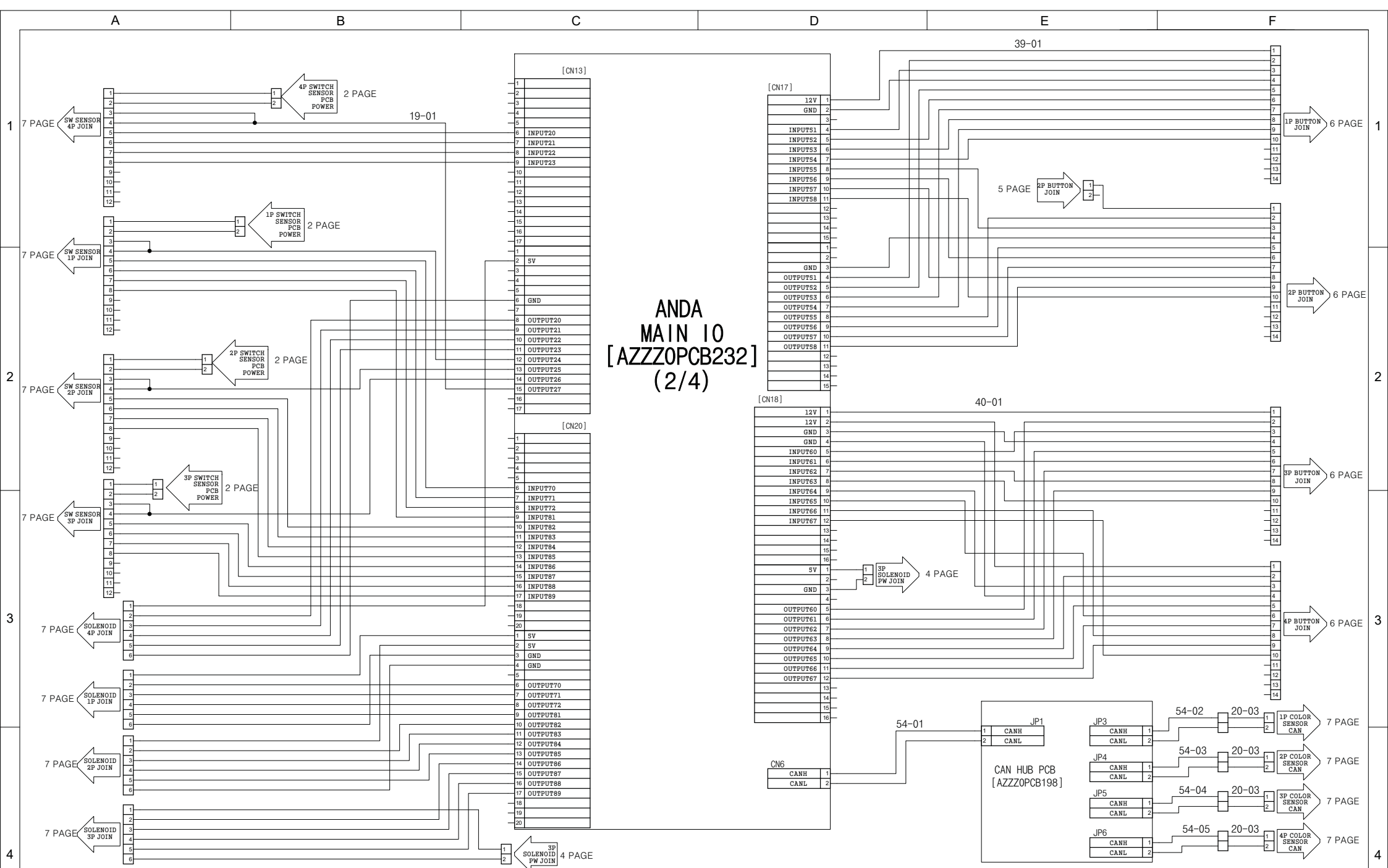

**ANDA  
MAIN IO  
[AZZZ0PCB232]  
(2/4)**

REPRODUCTION, DISTRIBUTION AND UTILIZATION OF THIS DOCUMENT AS WELL AS COMMUNICATION OF ITS CONTENTS TO OTHERS WITHOUT EXPRESS AUTHORIZATION PROHIBITED. OFFENDERS WILL BE HELD LIABLE FOR THE PAYMENT OF DAMAGES. ALL RIGHT RESERVED. COPYRIGHT (c) ANDAMIRO  
(복제, 배포 및 사용은 물론, 명시적 허가 없이는 타인에게 내용을 전달할 수 없으며 위반자는 손해 배상 책임을 집니다.)

DEPARTMENT	DRAWN BY	CHECKED BY	APPROVED BY	ITEM	<b>KRAZY BALLZ</b>
				PAGE	4PAGE
H/W				DATE	

1P,2P,3P,4P Common Ticket Dispenser  
Option

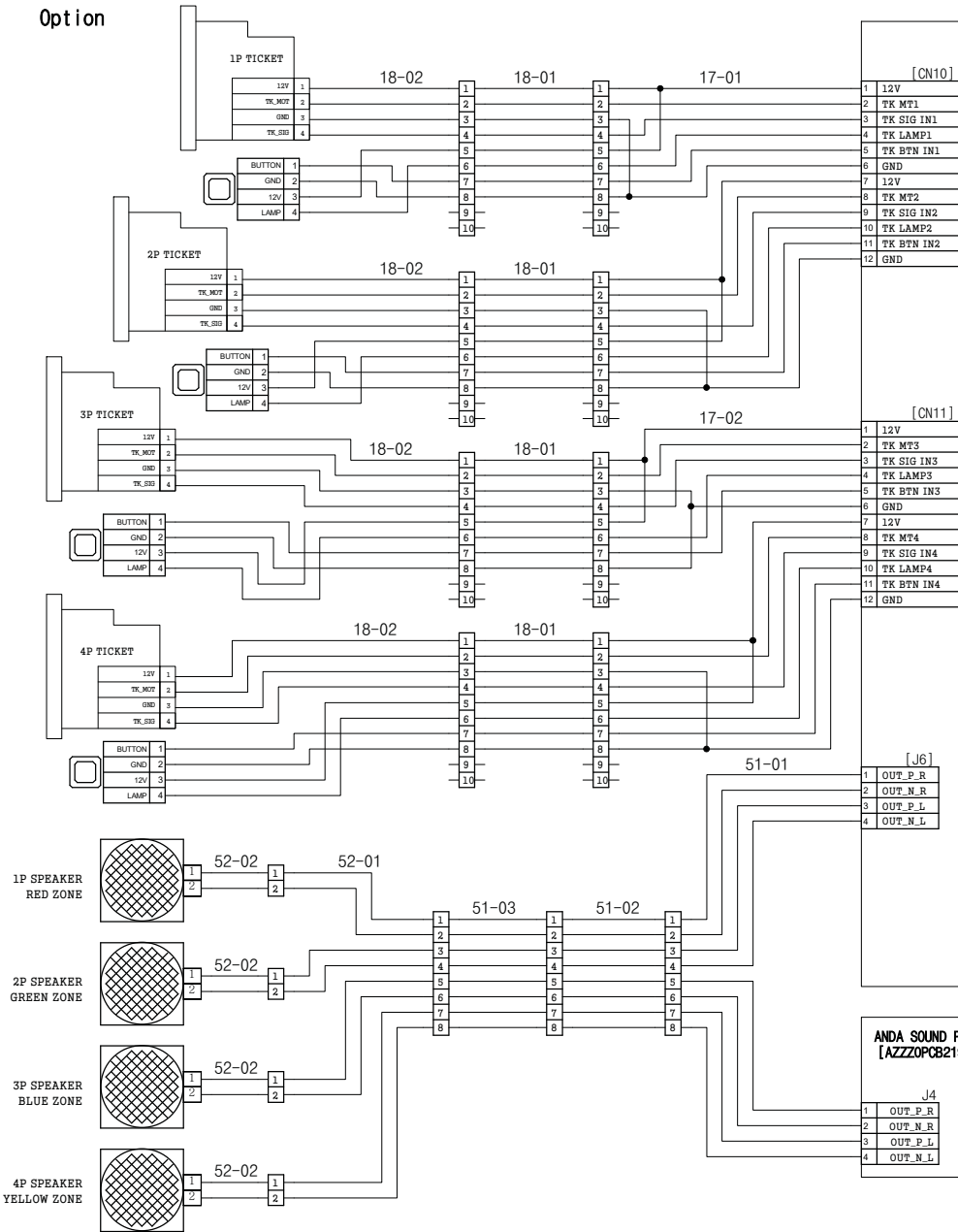

ANDA MAIN IO  
[AZZZOPCB232]  
(3/4)

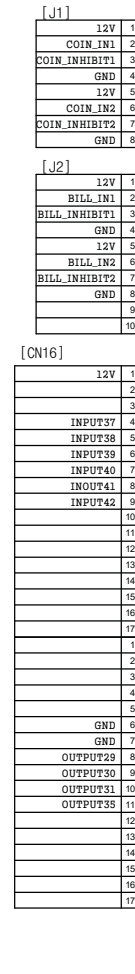



ANDA (4/4)  
 MAIN I/O  
 [AZZZOPCB232]

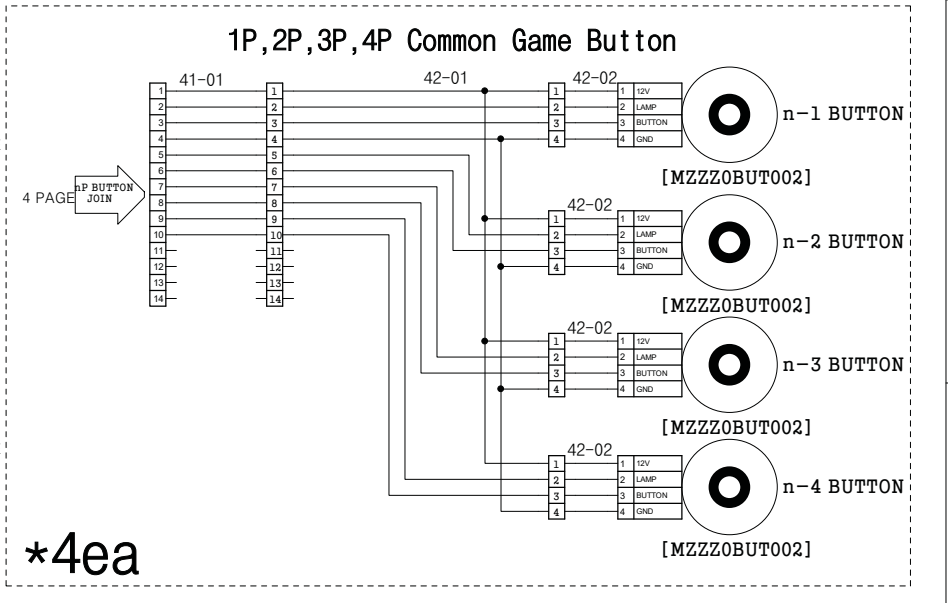
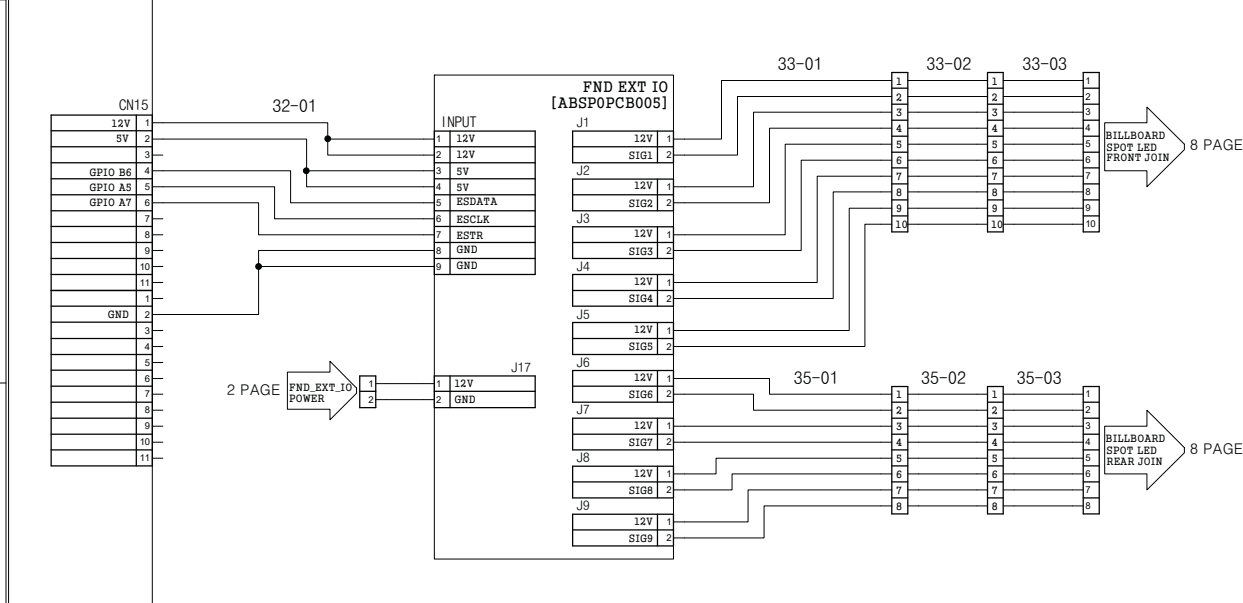
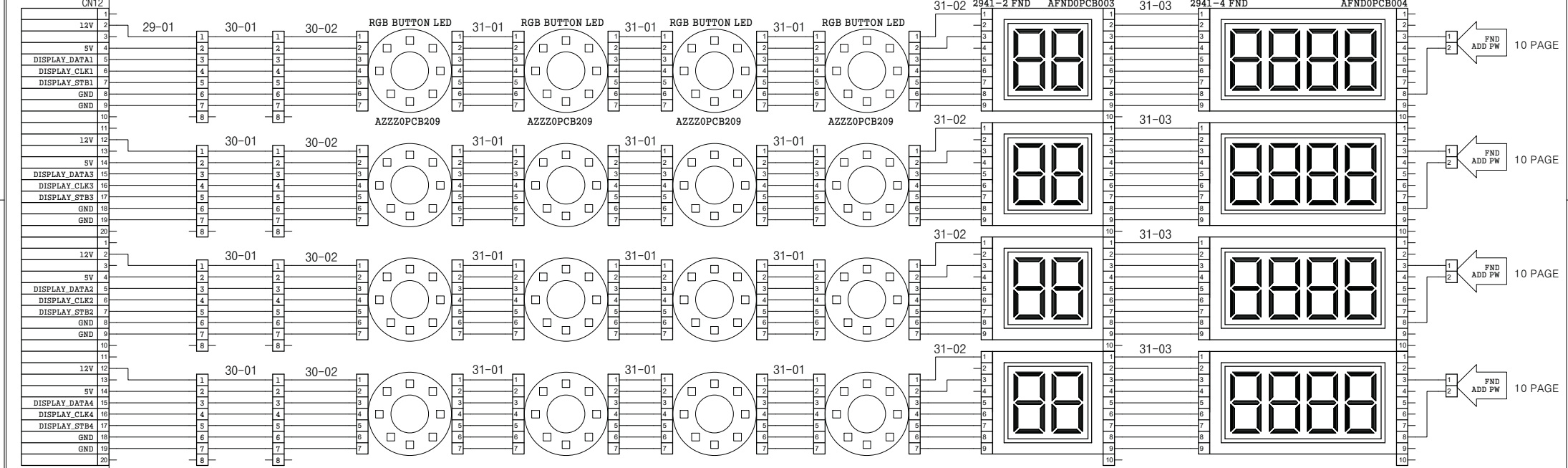

REPRODUCTION, DISTRIBUTION AND UTILIZATION OF THIS DOCUMENT AS WELL AS COMMUNICATION OF ITS CONTENTS TO OTHERS WITHOUT EXPRESS AUTHORIZATION PROHIBITED. OFFENDERS WILL BE HELD LIABLE FOR THE PAYMENT OF DAMAGES. ALL RIGHT RESERVED. COPYRIGHT (c) ANDAMIRO  
 (복제, 배포 및 사용은 물론, 명시적 허가 없이는 타인에게 내용을 전달할 수 없으며 위반자는 손해 배상 책임을 집니다.)

DEPARTMENT	DRAWN BY	CHECKED BY	APPROVED BY	ITEM	KRAZY BALLZ
H/W				PAGE	6PAGE
				DATE	

ANDAMIRO



1,2,3,4P Common

\*4ea

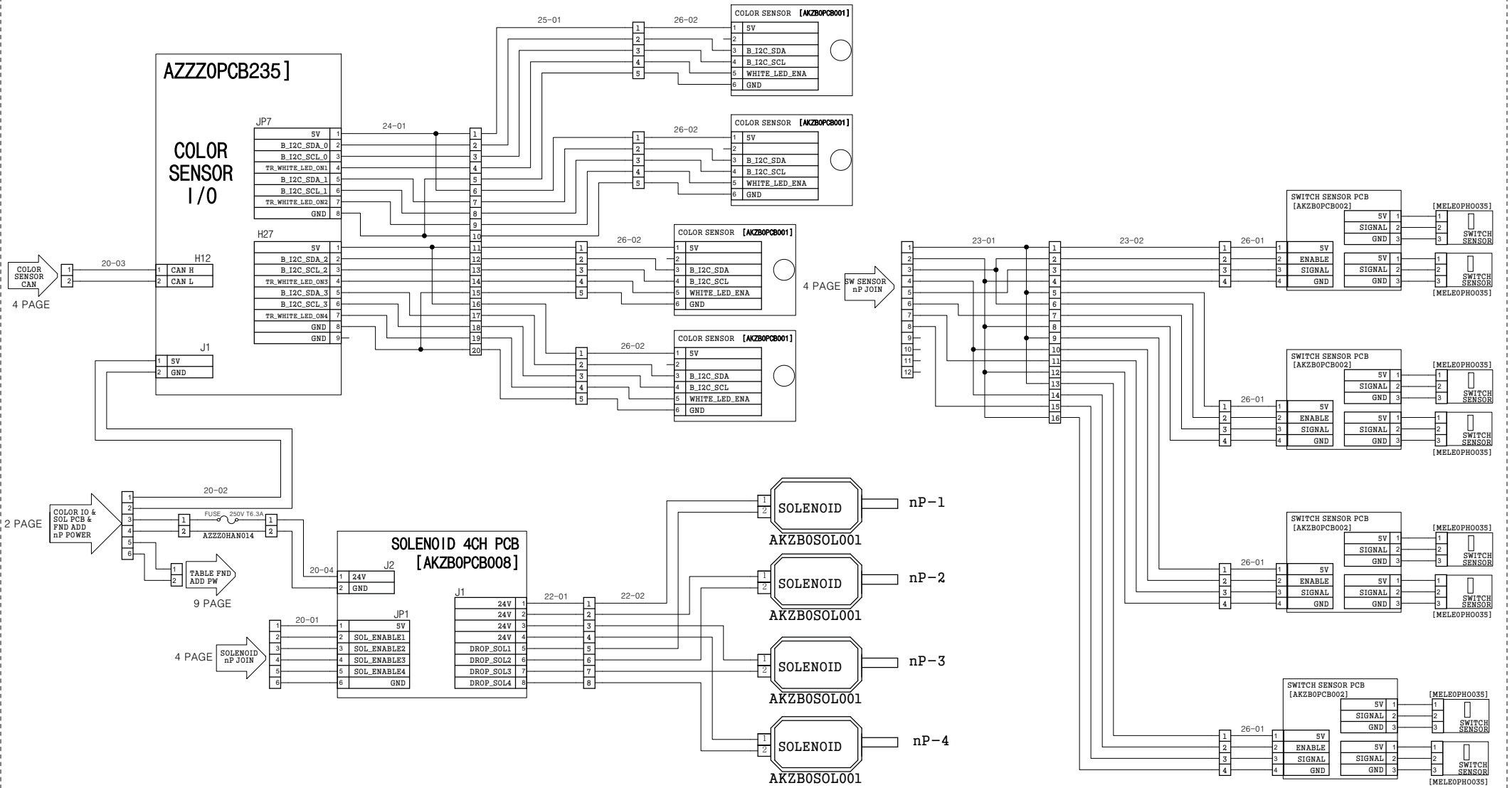

REPRODUCTION, DISTRIBUTION AND UTILIZATION OF THIS DOCUMENT AS WELL AS COMMUNICATION OF ITS CONTENTS TO OTHERS WITHOUT EXPRESS AUTHORIZATION PROHIBITED. OFFENDERS WILL BE HELD LIABLE FOR THE PAYMENT OF DAMAGES. ALL RIGHT RESERVED. COPYRIGHT (c) ANDAMIRO

(복제, 배포 및 사용은 물론, 명시적 허가 없이는 라인에게 내용을 전달할 수 없으며 위반자는 손해 배상 책임을 집니다.)

DEPARTMENT	DRAWN BY	CHECKED BY	APPROVED BY	ITEM	<b>KRAZY BALLZ</b>
H/W				PAGE	7PAGE
				DATE	

ANDAMIRO

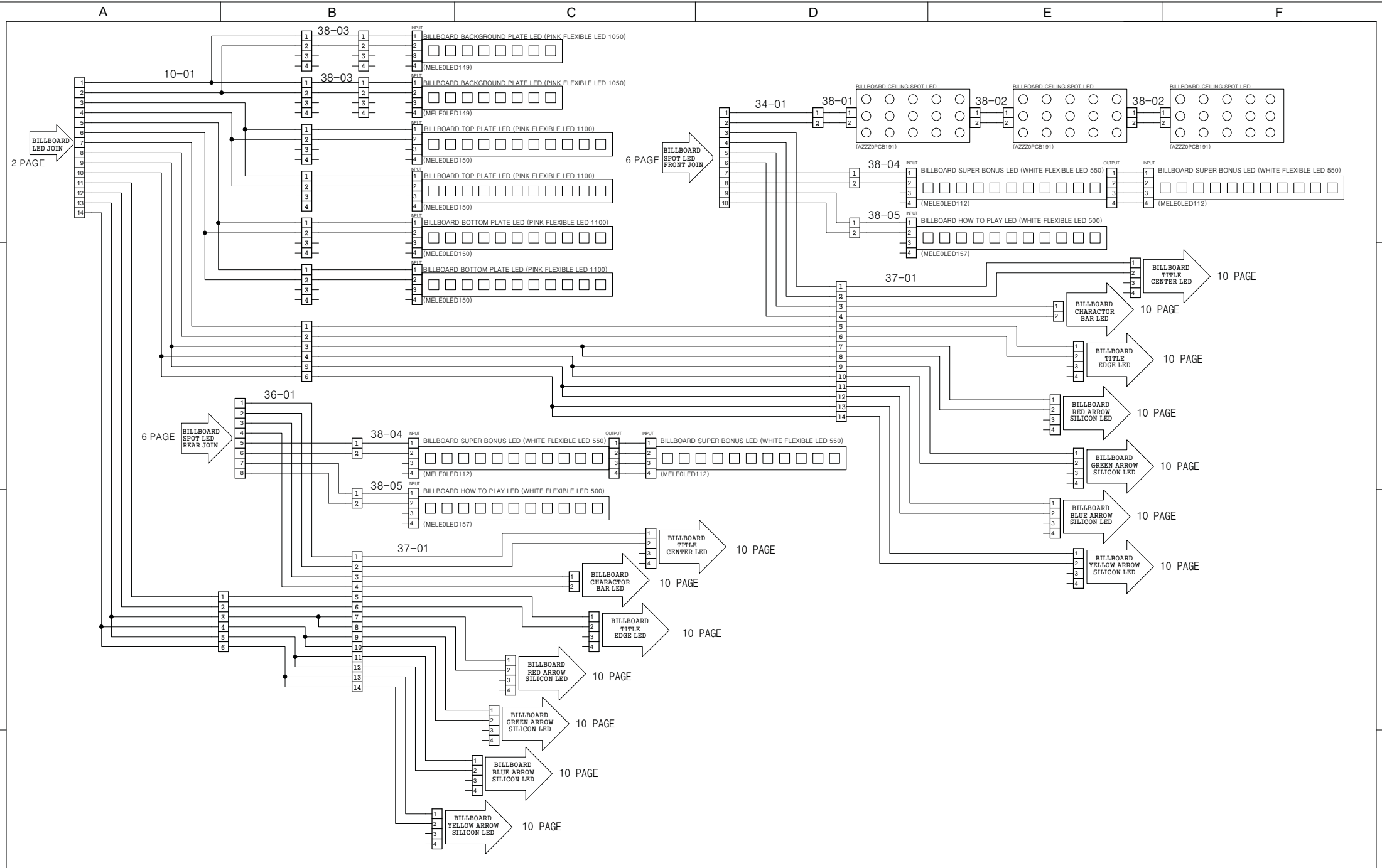

REPRODUCTION, DISTRIBUTION AND UTILIZATION OF THIS DOCUMENT AS WELL AS COMMUNICATION OF ITS CONTENTS TO OTHERS WITHOUT EXPRESS AUTHORIZATION PROHIBITED. OFFENDERS WILL BE HELD LIABLE FOR THE PAYMENT OF DAMAGES. ALL RIGHT RESERVED. COPYRIGHT (c) ANDAMIRO  
 (복제, 배포 및 사용은 물론, 명시적 허가 없이는 라인에게 내용을 전달할 수 없으며 위반자는 손해 배상 책임을 집니다.)

DEPARTMENT	DRAWN BY	CHECKED BY	APPROVED BY	ITEM	<b>KRAZY BALLZ</b>
H/W				PAGE	8PAGE
				DATE	



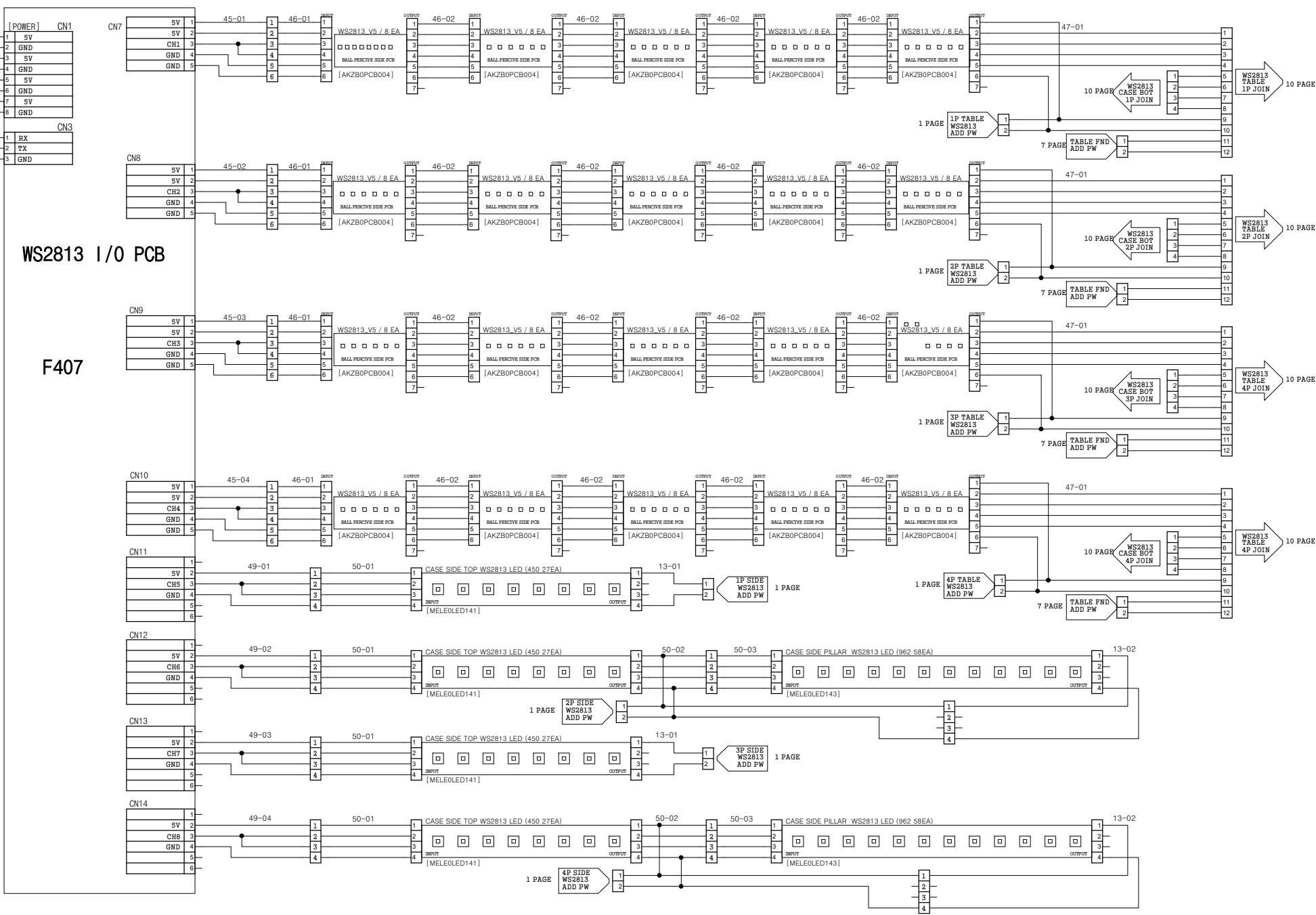

WS2813 I/O PCB

F407

REPRODUCTION, DISTRIBUTION AND UTILIZATION OF THIS DOCUMENT AS WELL AS COMMUNICATION OF ITS CONTENTS TO OTHERS WITHOUT EXPRESS AUTHORIZATION PROHIBITED. OFFENDERS WILL BE HELD LIABLE FOR THE PAYMENT OF DAMAGES. ALL RIGHT RESERVED. COPYRIGHT (c) ANDAMIRO

(복제, 배포 및 사용은 물론, 명시적 허가 없이는 타인에게 내용을 전달할 수 없으며 위반자는 손해 배상 책임을 집니다.)

DEPARTMENT	DRAWN BY	CHECKED BY	APPROVED BY	ITEM	KRAZY BALLZ
H/W				PAGE	9PAGE
				DATE	



1P,2P,3P,4P Common Table WS2813 LED

\*4ea

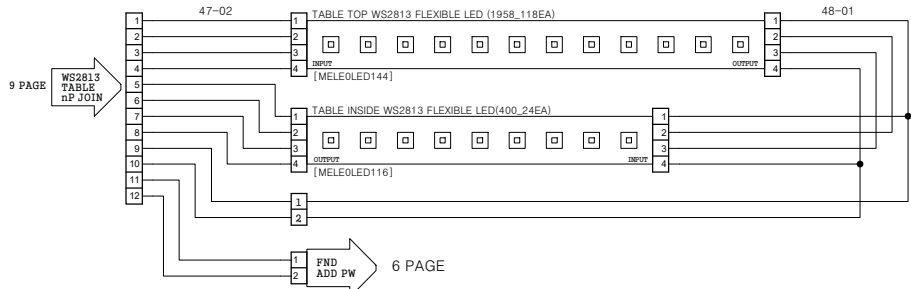

1P,2P,3P,4P Common Bottom WS2813 LED

\*4ea

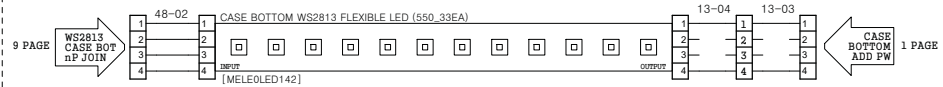

1,2P / ,3,4P Billboard Common Ass'y

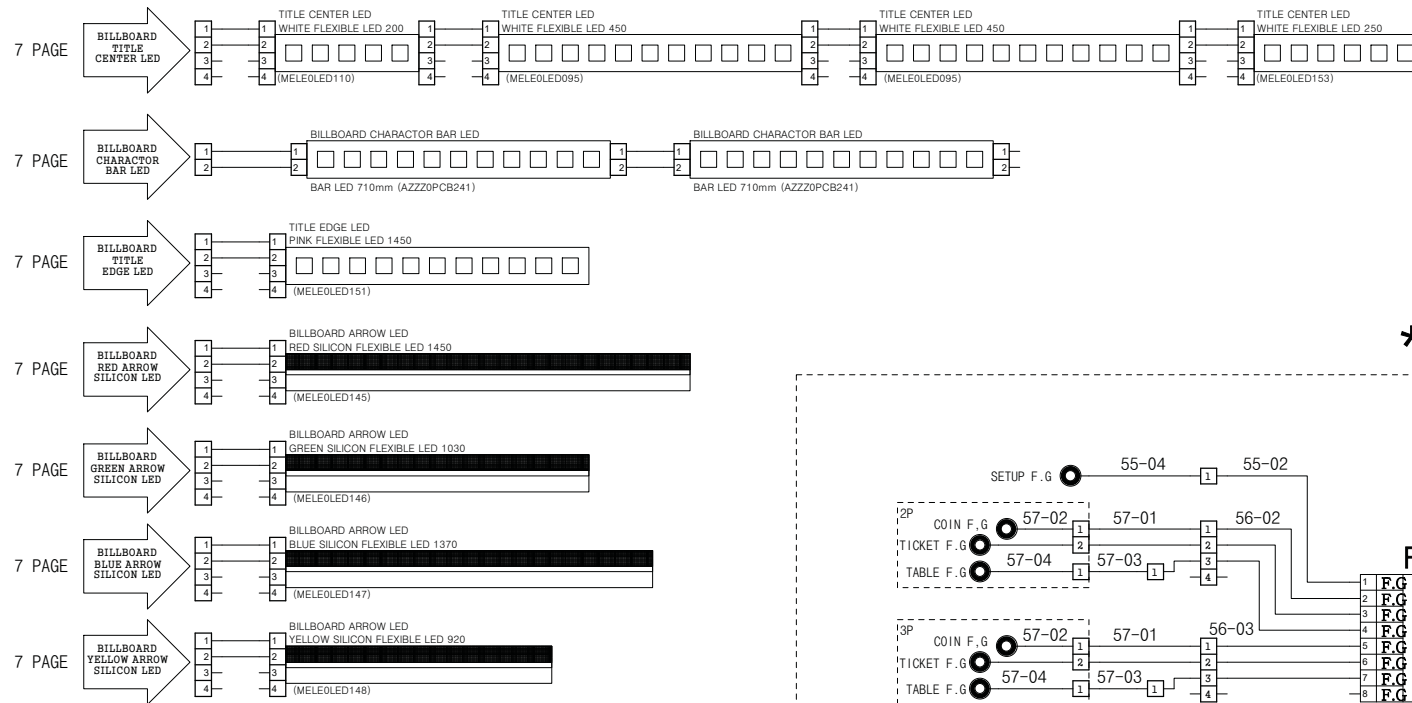

\*2ea

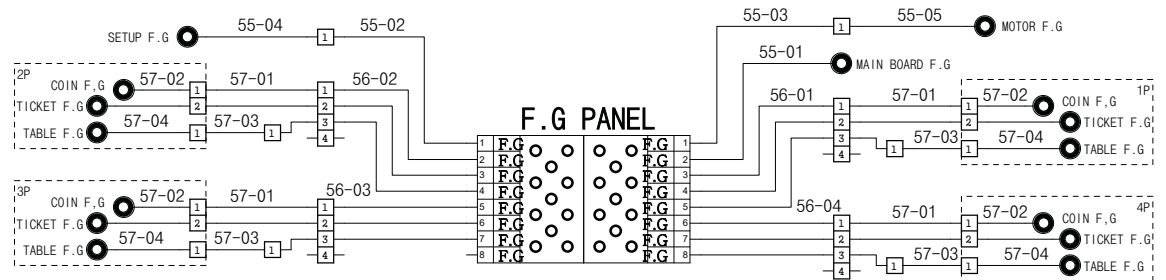

REPRODUCTION, DISTRIBUTION AND UTILIZATION OF THIS DOCUMENT AS WELL AS COMMUNICATION OF ITS CONTENTS TO OTHERS WITHOUT EXPRESS AUTHORIZATION PROHIBITED. OFFENDERS WILL BE HELD LIABLE FOR THE PAYMENT OF DAMAGES.ALL RIGHT RESERVED. COPYRIGHT (c) ANDAMIRO

(복제, 배포 및 사용은 물론, 명시적 허가 없이는 타인에게 내용을 전달할 수 없으며 위반자는 손해 배상 책임을 집니다.)

DEPARTMENT	DRAWN BY	CHECKED BY	APPROVED BY	ITEM	KRAZY BALLZ
H/W				PAGE	10PAGE
				DATE	

ANDAMIRO

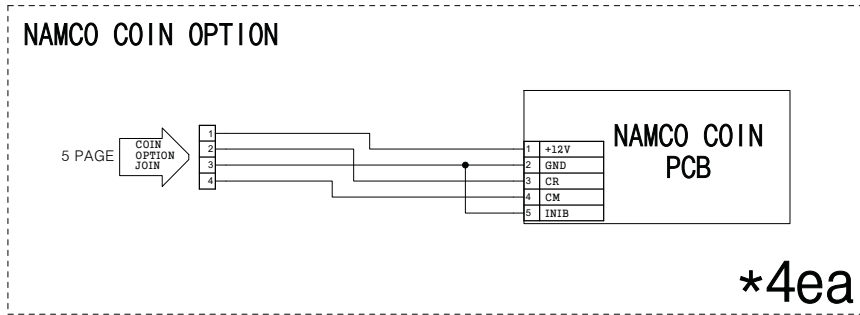
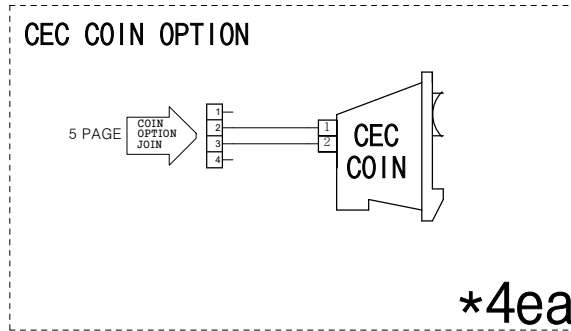
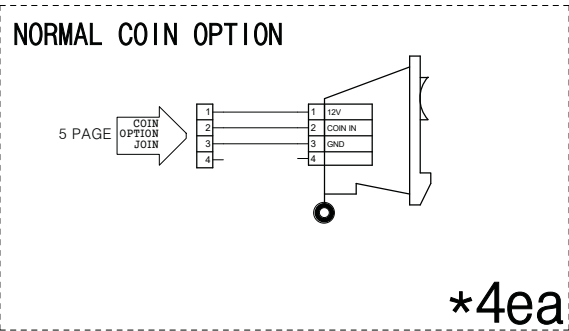

REPRODUCTION, DISTRIBUTION AND UTILIZATION OF THIS DOCUMENT AS WELL AS COMMUNICATION OF ITS CONTENTS TO OTHERS WITHOUT EXPRESS AUTHORIZATION PROHIBITED. OFFENDERS WILL BE HELD LIABLE FOR THE PAYMENT OF DAMAGES.ALL RIGHT RESERVED. COPYRIGHT (c) ANDAMIRO  
 (복제, 배포 및 사용은 물론, 명시적 허가 없이는 타인에게 내용을 전달할 수 없으며 위반자는 손해 배상 책임을 집니다.)

DEPARTMENT	DRAWN BY	CHECKED BY	APPROVED BY	ITEM	<b>KRAZY BALLZ</b>
H/W				PAGE	11PAGE
				DATE	

# 11. WARRANTY ITEM

- MAIN BOARD PART

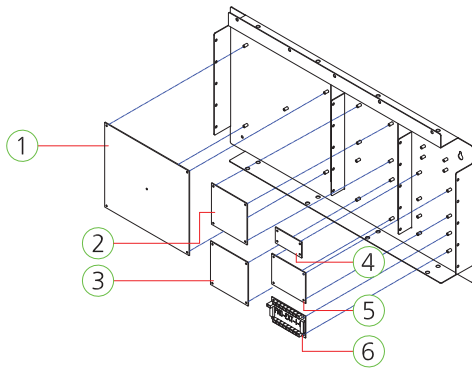

- SMPS PART

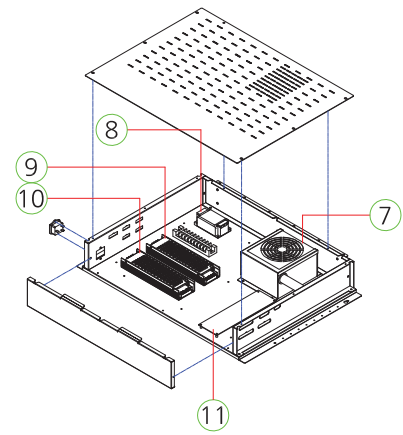

- CONTROL PANEL PART

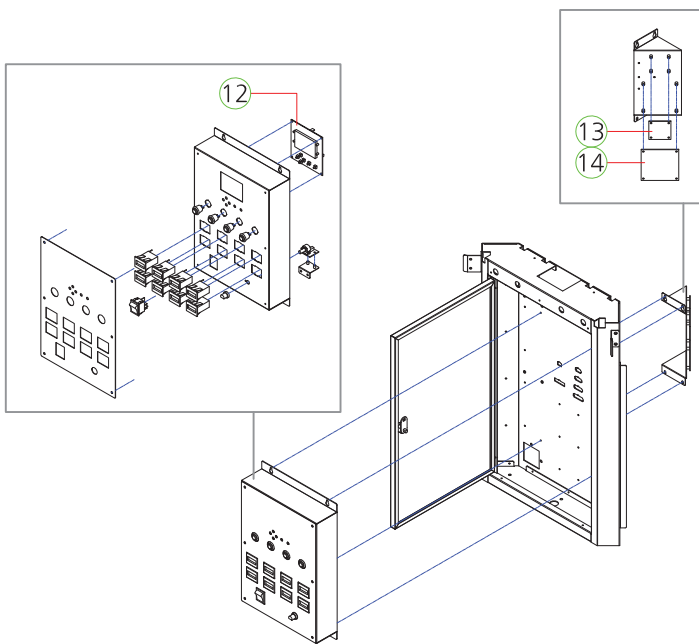

- BALL PERCEIVE BASE PART

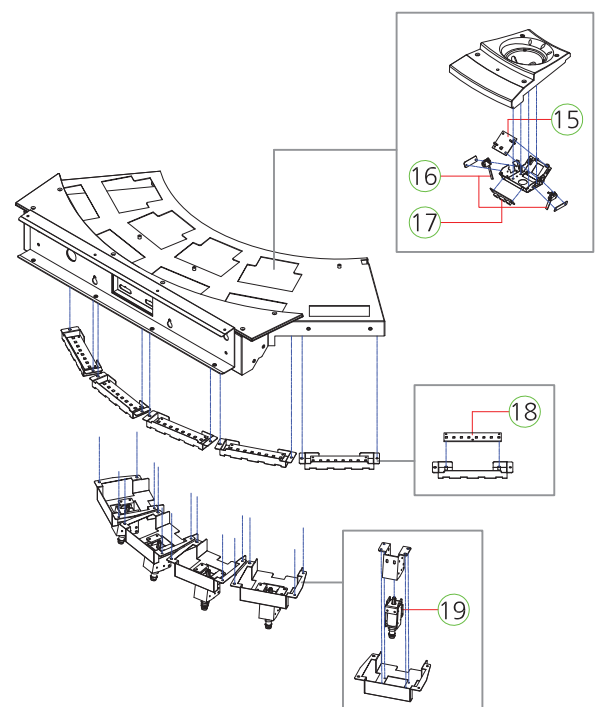

- BALL ROTATE PART

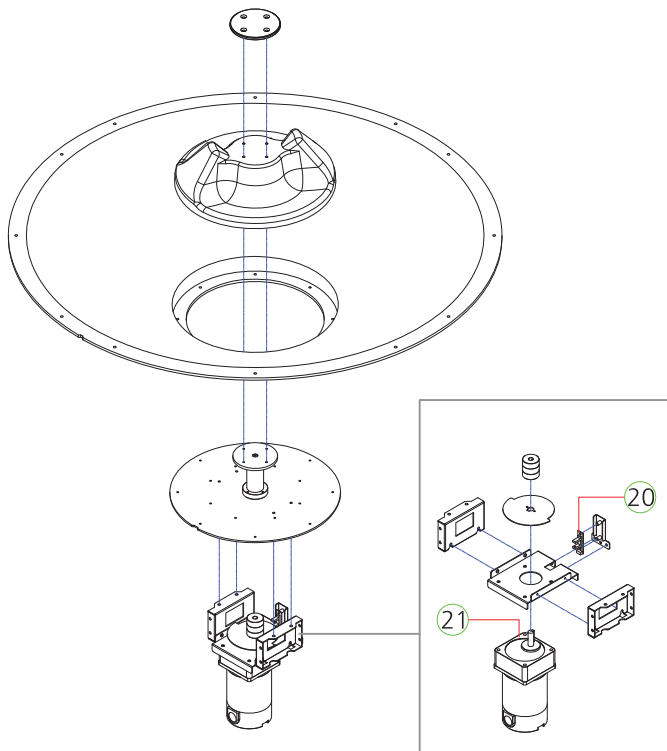

- BUTTON TABLE PART

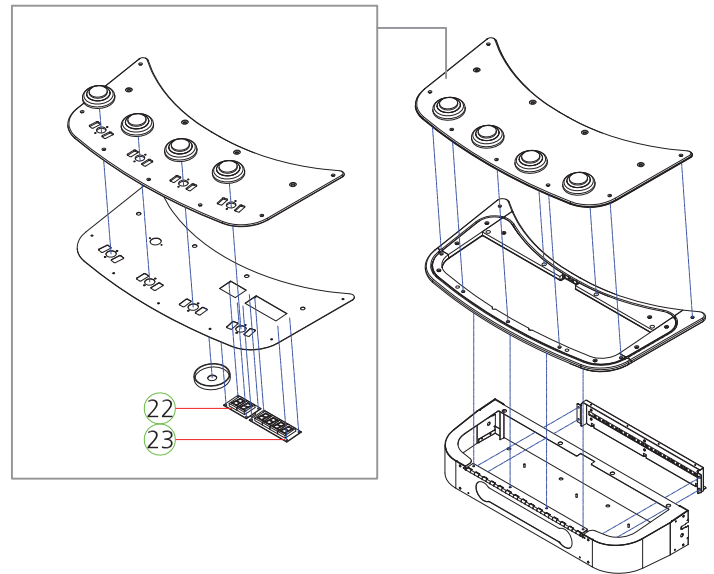

- SPEAKER BOX BASE PART

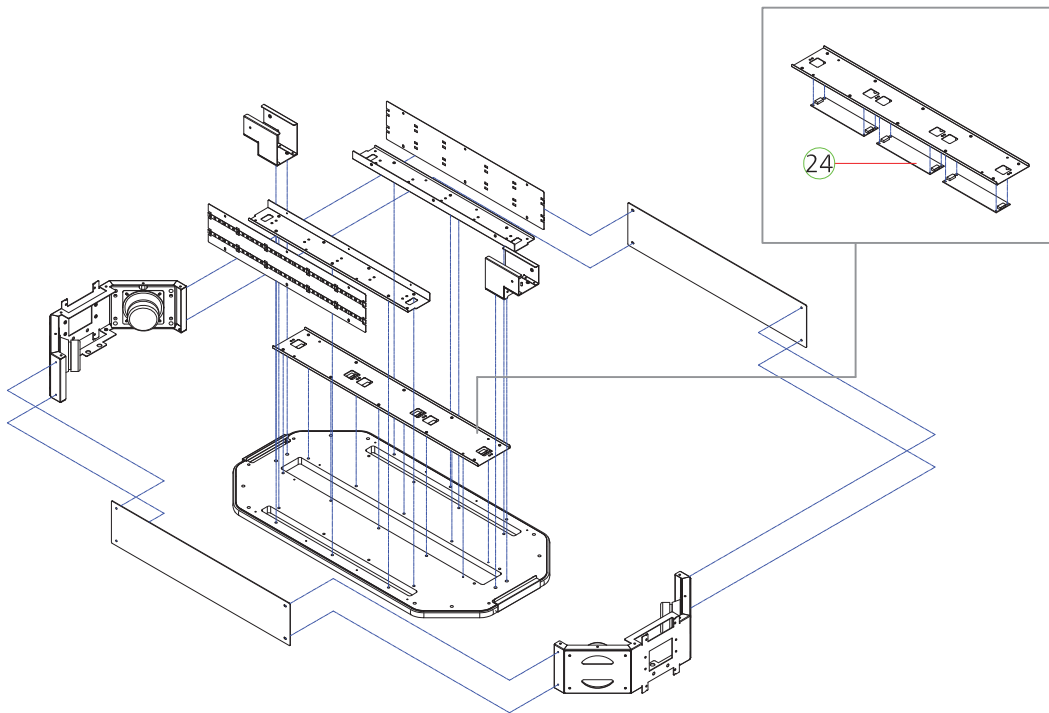

NO.	PART NAME	SPEC.	QTY	CODE NO.	WARRANTY	
					6 Month	One Year
①	ANDA MAIN V1.6 PCB ASS'Y	WITH TOP SOUND	1	AZZZ0ASS084		○
②	F407_WS2813B_IO PCB ASS'Y	-	1	AZZZ0PCB234		○
③	SOUND PCB ASS'Y	-	1	AZZZ0PCB219		○
④	STANDARD CAN HUB PCB ASS'Y	-	1	AZZZ0PCB198		○
⑤	L6205 2CH_V2 PCB ASS'Y	DC MOTOR DRIVER_V2	1	AZZZ0PCB231		○
⑥	FND-EXT-IO-PCB ASS'Y	90 X 50 16BIT EXT	1	ABSP0PCB005		○
⑦	ATX POWER	FSP750-50AAA	1	MELE0SMP157		○
⑧	NOISE FILTER	RNS-2010	1	MELE0NOI009		○
⑨	POWER SMPS	UHP-350-5V	1	MELE0SMP155		○
⑩	POWER SMPS	UHP-350-24V	1	MELE0SMP156		○
⑪	ATX JOIN PCB ASS'Y	24PIN 2OZ PCB	1	AZZZ0PCB246		○
⑫	SETUP LCD PCB ASS'Y	-	1	AZZZ0PCB113		○
⑬	SOL FET 4CH PCB ASS'Y	12V_24V_4CH	1	AZZZ0PCB233		○
⑭	COLOR SENSOR IO PCB ASS'Y	COLOR SENSOR IO 4CH	1	AZZZ0PCB235		○
[*Quantity per set]						
⑮	COLOR SENSOR PCB ASS'Y	-	1	AKZB0PCB001		○
⑯	PHOTO SENSOR	SG405CD_KODENSHI	2	MELE0PHO035		○
⑰	BALL SWITCH PCB ASS'Y	-	1	AKZB0PCB002		○
⑱	BALL PERCEIVE LED PCB ASS'Y	-	5	AJIE0PCB006		○
⑲	SOLENOID ASS'Y	DS12ES24V	5	AKZB0SOL001	○	
⑳	PHOTO-INT1 PCB ASS'Y	ANGLE TYPE	1	AZZZ0PCB103		○
㉑	MOTOR	K8D24V25W_K8G10C	1	MZZZ0MOT182	○	
㉒	FND PCB ASS'Y	2941-2(STRAIGHT)	1	AFND0PCB003		○
㉓	FND PCB ASS'Y	2941-4(STRAIGHT)	1	AFND0PCB004		○
㉔	NEW SPOT LED	ONE CHIP_WHITE	3	AZZZ0PCB191		○



## 12. TROUBLE SHOOTING

### 12-1. REGION ERROR (Er01)

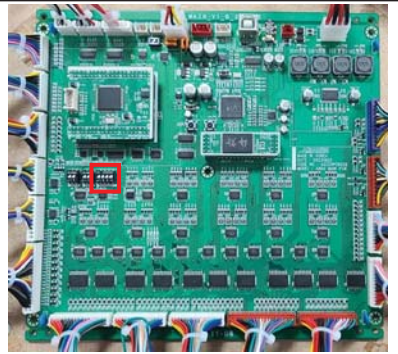
ERROR or LOCATION	► SOLUTION	
	1. CHECK : 1) Check the location of MAIN PCB DIP SW 6 2) Check after executing FACTORY SETTING 3) MAIN PCB replacement	
	PART NAME	CODE
	ANDA MAIN V1.6 PCB ASS'Y	AZZZ0ASS084

### 12-2. SYSTEM ERROR (Er02, Er03)

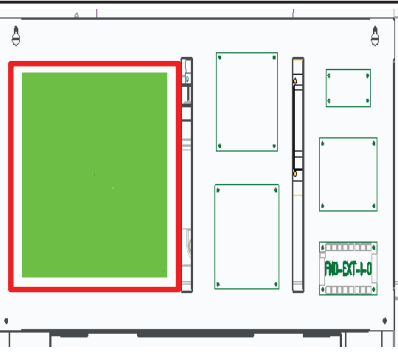
ERROR or LOCATION	► SOLUTION	
	1. CHECK : 1) Recheck after power off/on 2) Recheck after factory set 3) MAIN PCB replacement	
	PART NAME	CODE
	ANDA MAIN V1.6 PCB ASS'Y	AZZZ0ASS084

### 12-3. COIN MACHINE ERROR (Er.11)

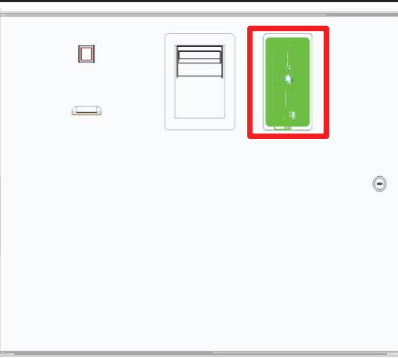
ERROR or LOCATION	► SOLUTION	
	1. TEST MODE → COIN TEST 2. CHECK : 1) Check whether COIN JAM 2) Check the cable connection status 3) REPLACE COIN MACHINE 4) MAIN PCB replacement	
	PART NAME	CODE
	COIN SELECTOR	MZZZ0COS052

### 12-4. BILL ACCEPTOR ERROR (Er.13)

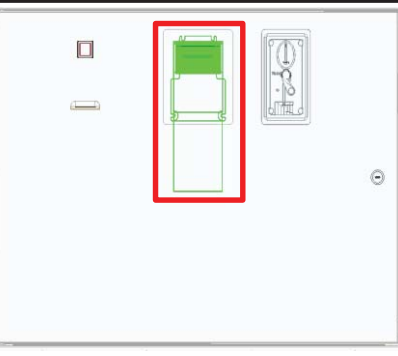
ERROR or LOCATION	► SOLUTION	
	1. TEST MODE → BILL TEST 2. CHECK : 1) Check whether BILL JAM 2) Check the cable connection status 3) REPLACE BILL ACCEPTOR 4) MAIN PCB replacement	
	PART NAME	CODE
	ANDA MAIN V1.6 PCB ASS'Y	AZZZ0ASS084

## 12-5. COLOR SENSOR COMMUNICATION ERROR (Er.21)

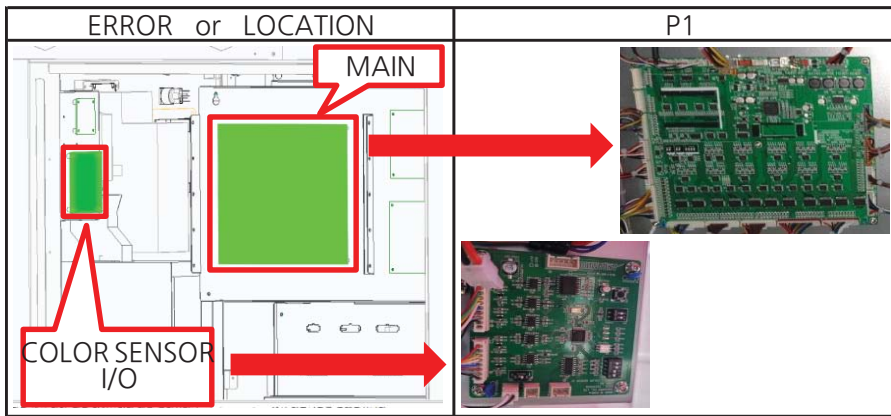

### ► SOLUTION

#### 1. CHECK :

- 1) Check wiring connection status (P1)
- 2) COLOR SENSOR IO PCB replacement
- 3) MAIN PCB replacement

PART NAME	CODE	PART NAME	CODE
COLOR SENSOR IO PCB ASS'Y	AZZZ0PCB235	ANDA MAIN V1.6 PCB ASS'Y	AZZZ0ASS084

## 12-6. COLOR SENSOR COMMUNICATION ERROR (Er.22)

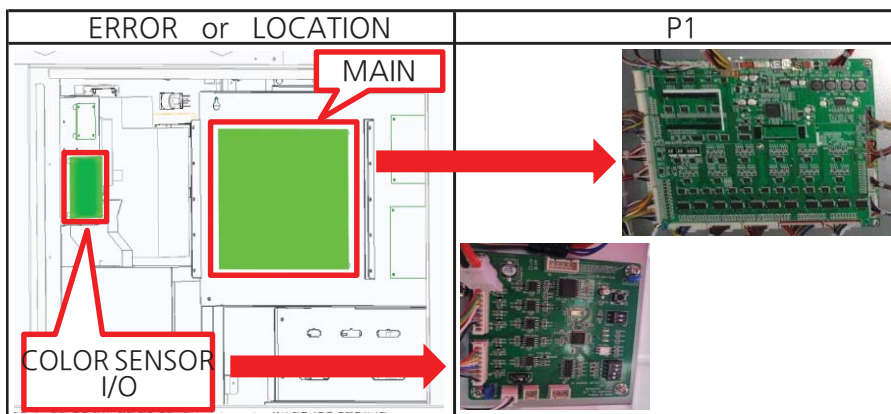

### ► SOLUTION

#### 1. CHECK :

- 1) Check COLOR SENSOR I/O version information in BOOKKEEPING DATA
- 2) Check wiring connection status (P1)
- 3) COLOR SENSOR IO PCB replacement
- 4) MAIN PCB replacement

PART NAME	CODE	PART NAME	CODE
COLOR SENSOR IO PCB ASS'Y	AZZZ0PCB235	ANDA MAIN V1.6 PCB ASS'Y	AZZZ0ASS084

## 12-7. COLOR SENSOR I/O SENSOR ERROR (Er.23)

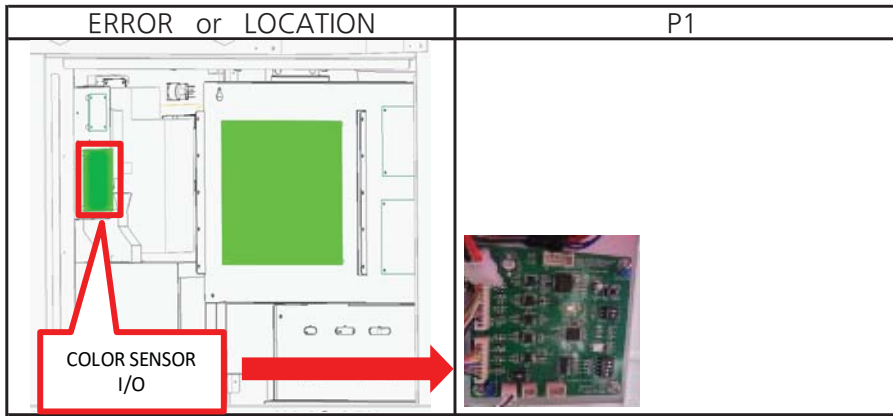

### ► SOLUTION

#### 1. CHECK

- 1) COLOR SENSOR IO PCB replacement
- 2) Check wiring connection status (P1)
- 3) Replace COLOR SENSOR PCB if COLOR is not recognized
- 4) Check after power OFF → ON

PART NAME	CODE	PART NAME	CODE
COLOR SENSOR IO PCB ASS'Y	AZZZ0PCB235	COLOR SENSOR PCB ASS'Y	AKZB0PCB001

## 12-8. MAIN SHUPPLE MOTOR & SENSOR ERROR (Er.31)

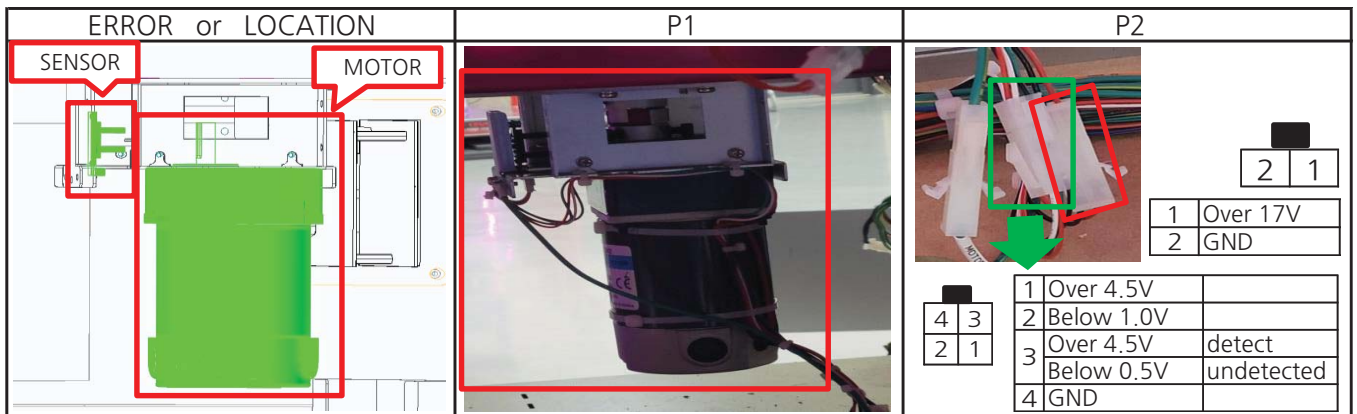

### ► SOLUTION

#### 1. TEST MODE → MOT SHUPPLE

- Operate using the SELECT button
- CREDIT FND: Main motor status display ("On", "OF", "CH")
- TICKET FND:
  - ① First digit: Main motor power status display ("0", "1")
  - ② Second digit: Indication of branch sensor operation status ("0", "1")
  - ③ 3rd and 4th digits: equinox sensor check count display ("00" ~ "99")

#### 2. CHECK :

- 1) Check motor mechanism and sensor BKT assembly status (P1)
- 2) Check wiring connection status (P1)
- 3) Motor voltage measurement (P2)
- 4) MOTOR replacement
- 5) SENSOR voltage measurement (P2)
- 6) SENSOR PCB replacement
- 7) MAIN PCB replacement

PART NAME	CODE	PART NAME	CODE
MOTOR ASS'Y	MZZZ0MOT182	PHOTO INT-1 PCB ASS'Y	AZZZ0PCB103
ANDA MAIN V1.6 PCB ASS'Y	AZZZ0ASS084		

## 12-9. SOLENOIDE ERROR (Er.41, Er.42, Er.43, Er.44)

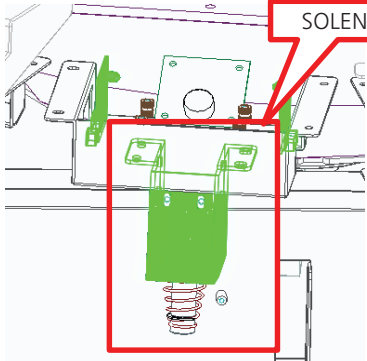
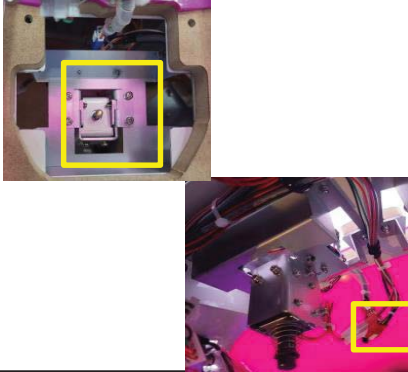
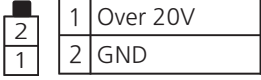
ERROR or LOCATION	P1	P2
		

### ► SOLUTION

1. TEST MODE → SOLENOIDE / COLOR SENSOR
  - Operate using the SELECT button
  - SOLENOIDE Description
    - ① CREDIT FND: Solenoid operation status display ("On", "OF")
    - ② TICKET FND: Indication of number for solenoid operation ("1P-1", "1P-2"~"4P-3", "4P-4")

2. CHECK :
  - 1) Check solenoid BKT assembly status (P1)
  - 2) Check wiring connection status (P1)
  - 3) Corresponding SOLENOIDE voltage measurement (P2)
  - 4) SOLENOIDE Replacement
  - 5) SOL 4CH PCB Replacement
  - 6) MAIN PCB replacement

PART NAME	CODE	PART NAME	CODE
SOLENOID ASS'Y	AKZB0SOL001	SOL FET 4CH PCB ASS'Y	AZZZ0PCB233
ANDA MAIN V1.6 PCB ASS'Y	AZZZ0ASS084		

## 12-10. MAIN SHUPPLE ERROR (Er.45)

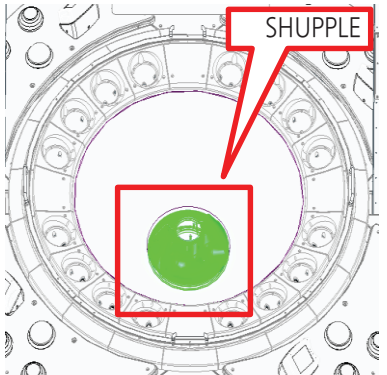
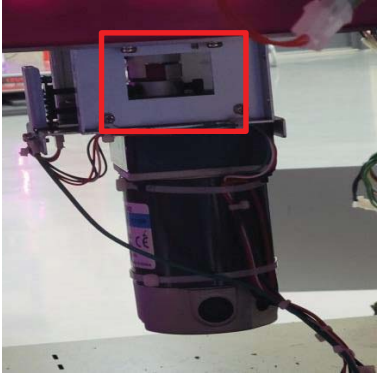
ERROR or LOCATION	P1
	

### ► SOLUTION

1. CHECK
  - 1) Assemble motor and SHUPPLE equipment and check coupling assembly status
  - 2) Coupling replacement
  - 3) SHUPPLE injection mold replacement

PART NAME	CODE	PART NAME	CODE
COUPLING	MZZZ0MOT182	BALL ROTATE MOLD	MKZB0PLA003

## 12-11. COLOR SENSOR ERROR (Er.51,Er.52, Er.53, Er.54)

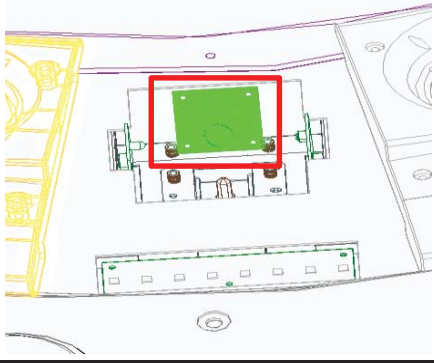
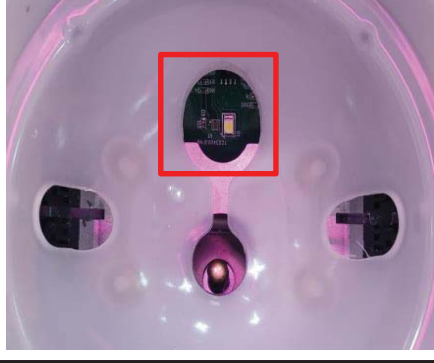
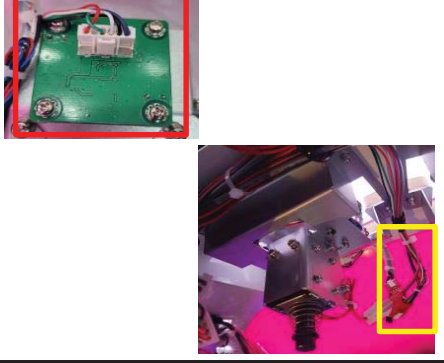

ERROR or LOCATION	P1	P2
		

### ► SOLUTION

- |  |  |
|--|--|
| <p>1. TEST MODE → COLOR SENSOR</p> <ul style="list-style-type: none"> <li>▶ Operate using the SELECT button</li> <li>▶ CREDIT FND:Color sensor operation status display ("On"."OF")</li> <li>▶ TICKET FND:Color sensor ball recognition color display ("R","G","B","Y","P")</li> </ul> | <p>2. CHECK :</p> <ol style="list-style-type: none"> <li>1) Check assembly status of COLOR SENSOR equipment (P1)</li> <li>2) Check wiring connection status (P2)</li> <li>3) Replace the corresponding COLOR SENSR PCB</li> <li>4) COLOR I/O PCB replacement</li> <li>5) MAIN PCB replacement</li> </ol> |
|--|--|

PART NAME	CODE	PART NAME	CODE
COLOR SENSOR PCB ASS'Y	AKZB0PCB001	COLOR SENSOR IO PCB ASS'Y	AZZZ0PCB235
ANDA MAIN V1.6 PCB ASS'Y	AZZZ0ASS084		

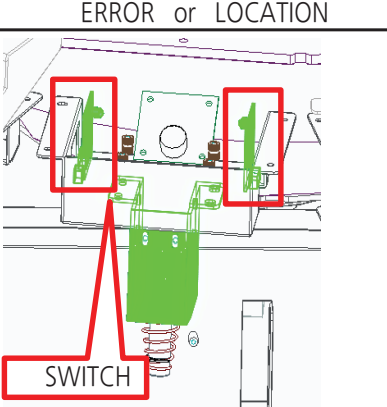
## 12-12. BALL LANDING RECOGNITION SWITCH ERROR (Er.61, Er.62, Er.63, Er.64)

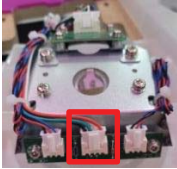
ERROR or LOCATION	P1	P2																								
	 	 <table border="1" data-bbox="922 1435 1251 1630"> <tr> <td>4</td> <td>3</td> <td>2</td> <td>1</td> </tr> <tr> <td>1</td> <td>Over 4.5V</td> <td></td> <td></td> </tr> <tr> <td>2</td> <td>Below 1.0V</td> <td></td> <td></td> </tr> <tr> <td>3</td> <td>Over 4.5V</td> <td>detect</td> <td></td> </tr> <tr> <td></td> <td>Below 0.5V</td> <td>undetected</td> <td></td> </tr> <tr> <td>4</td> <td>GND</td> <td></td> <td></td> </tr> </table>	4	3	2	1	1	Over 4.5V			2	Below 1.0V			3	Over 4.5V	detect			Below 0.5V	undetected		4	GND		
4	3	2	1																							
1	Over 4.5V																									
2	Below 1.0V																									
3	Over 4.5V	detect																								
	Below 0.5V	undetected																								
4	GND																									

### ► SOLUTION

- |   |  |
|---|--|
| <p>1. TEST MODE → SOLENOIDE / COLOR SENSOR</p> <ul style="list-style-type: none"> <li>▶ Operate using the SELECT button</li> <li>▶ COLOR SENSOR DESCRIPTION</li> <li>① CREDIT FND:IR sensor operation status display ("On"."OF")</li> <li>② TICKET FND:Displayed as a dot when the IR sensor detects a ball (□.□.□.□.)</li> </ul> | <p>2. CHECK :</p> <ol style="list-style-type: none"> <li>1) Check IR PCB and BKT assembly status (P1)</li> <li>2) Check wiring connection status (P1)</li> <li>3) Measure the corresponding IR SENSOR voltage(P2)</li> <li>4) IR SENSOR PCB replacement</li> <li>5) BALL SWITCH PCB ASS'Y replacement</li> <li>6) COLOR SENSOR I/O replacement</li> <li>7) MAIN PCB replacement</li> </ol> |
|---|--|

PART NAME	CODE	PART NAME	CODE
KODENSHI SH405CD SENSOR	MELE0PHO035	BALL SWITCH PCB ASS'Y	AKZB0PCB002
COLOR SENSOR IO PCB ASS'Y	AZZZ0PCB235	ANDA MAIN V1.6 PCB ASS'Y	AZZZ0ASS084



## 12-13. SOLENOIDE EXCEPTION HANDLING ERROR (Er.71, Er.72, Er.73, Er.74)

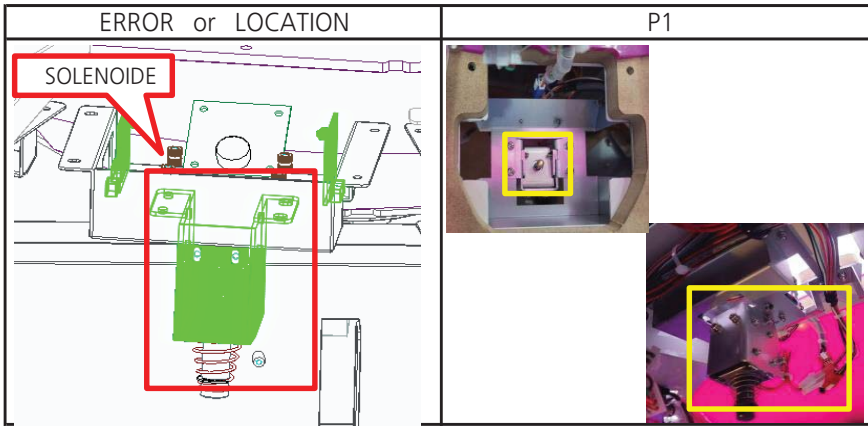

► SOLUTION			
<p>1. TEST MODE → SOLENOIDE / COLOR SENSOR</p> <ul style="list-style-type: none"> <li>► Operate using the SELECT button</li> <li>► SOLENOIDE Description                             <ul style="list-style-type: none"> <li>① CREDIT FND: Solenoid operation status display ("On", "OF")</li> <li>② TICKET FND: Indication of number for solenoid operation ("1P-1", "1P-2"~"4P-3", "4P-4")</li> </ul> </li> </ul>		<p>2. CHECK :</p> <ul style="list-style-type: none"> <li>1) Check solenoid BKT assembly status (P1)</li> <li>2) Check wiring connection status (P1)</li> <li>3) Turn the product power OFF → ON and recheck</li> <li>4) SOLENOIDE REPLACEMENT</li> <li>5) MAIN PCB replacement</li> </ul>	
PART NAME	CODE	PART NAME	CODE
SOLENOID ASS'Y	AKZB0SOL001	ANDA MAIN V1.6 PCB ASS'Y	AZZZ0ASS084

## 12-14. TICKET ERROR (HELP)

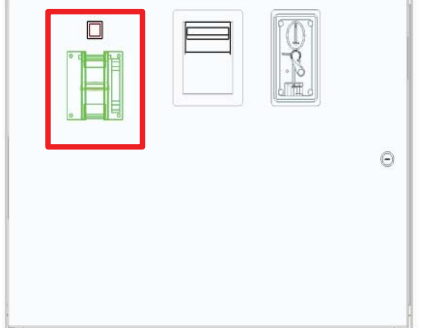
ERROR or LOCATION	► SOLUTION			
	<p>1. TEST MODE → TICKET TEST</p> <p>2. CHECK :</p> <ul style="list-style-type: none"> <li>1) Check whether TICKET JAM</li> <li>2) Check the cable connection status</li> <li>3) REPLACE TICKET DISPENSER</li> <li>4) MAIN PCB replacement</li> </ul>			
PART NAME	CODE	PART NAME	CODE	
TICKET DISPENSER	MZZZ0TID010	ANDA MAIN V1.6 PCB ASS'Y	AZZZ0ASS084	



## **ANDAMIRO WARRANTY POLICY**



Andamiro warrants to the original purchaser that all of its products will be free from defects in material and workmanship.

**Andamiro warrants the parts from date of shipment as follows.**

- **One Year Limited Warranty : Electronic Boards**
- **6 Months Limited Warranty : Moving Parts**

For any key components within the warranty period, Andamiro will repair or replace defective components free of charge.

When placing a warranty request, the customer is requested to furnish the following information:

1. Name of the game.
2. Serial Number of the game.
3. A Detailed Description of the defect/s experienced.

This warranty does not apply to the defects caused due to misuse or abuse of the product.

Any alterations made to game or game parts will void this warranty.

For warranty details on our product range please visit our website, [www.andamiro.com](http://www.andamiro.com).

ANDAMIRO CO., LTD.  
[www.andamiro.com](http://www.andamiro.com)







---

**ANDAMIRO CO., LTD.**  
TEL : 82-31-909-2123~5

**[ADDRESS OFFICE]** 704-1 Techno Town, 138, Ilsan-ro, Ilsandong-gu, Goyang-si,  
Gyeonggi-do, Republic of Korea 10442  
**[FACTORY]** 72 Nochemgil, Ilsan-donggu Goyang-si, Gyonggi-do, 410-834 korea

**USA BRANCH**  
ANDAMIRO USA CORP.  
TEL : 1-310-767-5800

**[ADDRESS USA]** 2222 Century Cir, Irving TX 75062 U.S.A

Homepage <http://www.andamiro.com/>