

*** ANDAMIRO WARRANTS the parts from date of shipment as follows.**

- One Year Limited Warranty : Electronic Boards**
- 6 Month Limited Warranty : Moving Parts**

CONTENTS

1. ERROR CODEP02
2. TEST MODEP04
3. TROUBLESHOOTINGP11
4. PART LISTP45

[1. ERROR CODE]

CODE (TOKENS FND)	CONTENTS	ERROR DESCRIPTION (REBOOTING AFTER TROUBLE SHOOTING)
E.02	COIN ERROR	1. COIN JAM ('COIN JAM' Trouble shooting in the coin acceptor)
E.03	CIRCULATION ERROR	1. CIRCULATION MEDAL JAM INSIDE OR NO MEDAL (Remove the acrylic plate OR Pull down jammed medal using magnet outside of acrylic plate) 2. MALFUNCTION OF UPPER SENSOR (TEST MODE -> CIRCULATION TEST : Check Circulator's operation)
E.04	PUSHER ERROR	1. MALFUNCTION OF AC MOTOR OR SENSOR (TEST MODE -> PUSHER TEST : Check MOTOR's operation) 2. MEDAL JAM at the PUSHER's bottom part or either side of upper part.
E.05	COUNTER HOPPER ERROR	1. MALFUNCTION OF MOTOR OR SENSOR (TEST MODE -> COUNTER HOPPER TEST : Check operation) 2. CONVEYER Check operation (TEST MODE -> CONVEYER TEST Check operation)
E.06	ELEVATOR HOPPER ERROR	1. MALFUNCTION OF MOTOR OR SENSOR (TEST MODE -> ELEVATOR HOPPER TEST Check operation) 2. NO MEDAL IN THE ELEVATOR HOPPER (Check MEDAL was dropped around.) 3. MEDAL JAM AT THE RAIL WHERE MEDAL WAS EMITTED (Remove MEDAL at the RAIL) 4. Check COUNTER HOPPER's operation (TEST MODE -> COUNTER HOPPER TEST : Check operation) 5. Check CONVEYER's operation (TEST MODE -> CONVEYER TEST : Check operation) 6. In case of MEDAL wasn't emitted even though there is MEDAL in the ELEVATOR HOPPER (Tap the bucket lightly several times.)
E.07	CIRCULATION WIPER ERROR	1. MALFUNCTION OF MOTOR OR SENSOR (TEST MODE -> CIRCULATION TEST : Check operation)
E.08	CONVEYER ERROR	1. MALFUNCTION OF MOTOR OR SENSOR (TEST MODE -> CONVEYER TEST : Check operation) 2. MEDAL JAM at the bottom part or upper part.

E.08	CONVEYER ERROR	<ol style="list-style-type: none"> 1. MALFUNCTION OF MOTOR OR SENSOR (TEST MODE -> CONVEYER TEST : Check operation) 2. MEDAL JAM at the bottom part or upper part. (TROBLE SHOOTING MEDAL JAM)
E.09	CIRCULATION ENCODER SENSOR ERROR	<ol style="list-style-type: none"> 1. MALFUNCTION OF MOTOR OR ENCODER SENSOR (TEST MODE -> CIRCULATION TEST : Check operation) 2. Check the clearance of the acrylic panel. (Adjust to spin it by hand and the clearance is less than 2cm)
E.10	CIRCULATION MAGNETIC SENSOR PCB ERROR	<ol style="list-style-type: none"> 1. MALFUNCTION OF SENSOR PCB in the bottom part of CIRCULATION (TEST MODE -> CIRCULATION TEST : Check operation)
E.11	CARD DISPENSER ERROR	<ol style="list-style-type: none"> 1. CARD EMPTY 2. CARD JAM (CARDS need to be shuffled when it put and lay in the H frame.)
E.12	BILL ACCEPT ERROR	<ol style="list-style-type: none"> 1. Signal outputs consistently from the Bill Acceptor. (Check the Bill Acceptor)
E.20	SETUP LCD ERROR	<ol style="list-style-type: none"> 1. MALFUNCTION OF SETUP LCD (Check the connection of MAIN BOARD connector)
E.21	CONNECT ERROR	<ol style="list-style-type: none"> 1. MALFUNCTION OF COMMUNICATION CONNECTION (Check the DIP-SWITCH ID of MAIN BOARD or connector line.)
E.22	PROGRAM VERSION ERROR	<ol style="list-style-type: none"> 1. MISMATCH ON EACH MAIN BOARD OF PROGRAM VERSION
E.23	BACKUP SETUP DATA ERROR	<ol style="list-style-type: none"> 1. SETUP STORAGE DATA ERROR (Rebooting the Machine. Then Clear error. CPU PCB needs to be changed if it occurs continuously.)
E.24	BACKUP GAME DATA ERROR	<ol style="list-style-type: none"> 1. SETUP STORAGE DATA ERROR (Rebooting the Machine. Then Clear error. CPU PCB needs to be changed if it occurs continuously.)
TILT ERROR	DISPLAY BONUS FND	It occurs machine was shaken. It automatically recovers after 15 seconds.

[2. TEST MODE]

● TEST MODE		
LCD DISPLAY	STATUS	DESCRIPTION
INPUT TEST	(REFER TO THE TABLE BELOW)	TEST INPUT SIGNAL
LED&FND&LAMP	OFF/ON/STEP ON/OFF	TEST THE STATUS OF LED&FND&LAMP OFF : TOTAL OFF ON : TOTAL ON STEP : ACT ACCORDING TO THE SPECIFIED SEQUENCE ON/OFF : ON AND OFF OPERATE CONSTANTLY
CIRCULATION 1 PLAYER OFF 2 PLAYER OFF ALL PLAYERS TEST VIEW EXIT	OFF/ON (DISPLAY OF OPERATION STAUS)	TEST CIRCULATION AND WIPER TICKET FND : DISPLAY THE STATUS OF WIPER SENSOR PLAYS FND : DISPLAY THE STATUS OF UPPER TOKEN SENSOR IN CIRCULATION TARGETFND : DISPLAY THE STATUS OF EACH ZONE SENSOR IN CIRCULATION TEST VIEW : DISPLAYS THE NUMBER OF TIMES EACH SENSOR HAS ENTERED
PUSHER 1 PLAYER OFF 2 PLAYER OFF ALL PLAYERS EXIT	OFF/ON (DISPLAY OF OPERATION STAUS)	TEST PUSHER MOTOR MOVEMENT TICKET FND : DISPLAY THE STATUS OF PUSHER MOTOR
ELEVATORHOPPER 1 PLAYER OFF 2 PLAYER OFF EXIT	OFF/ON (DISPLAY OF OPERATION STAUS)	TEST THE MOVEMENTOF ELEVATORHOPPER AFTER DISPENSING 3 TOKENS, STOP AUTOMATICALLY TICKET FND : DISPLAY THE STATUS OF SENSOR PLAY FND : THE NO. OF DISPENSED TOKENS
COUNTER HOPPER 1 PLAYER OFF 2 PLAYER OFF EXIT	OFF/ON (DISPLAY OF OPERATION STAUS)	TEST THE MOVEMENTOF COUNTER HOPPER AFTER DISPENSING 3 TOKENS, STOP AUTOMATICALLY TICKET FND : DISPLAY THE STATUS OF SENSOR PLAY FND : THE NO. OF DISPENSED TOKEN

CARD DISPENSER 1 PLAYER OFF 2 PLAYER OFF EXIT	OFF/ON (DISPLAY OF OPERATION STAUS)	TEST THE MOVEMENT OF CARD DISPENSER ON TESTING, THIS DISPENSES A CARD AND STOPS AUTOMATICALLY TICKET FND : DISPLAYS THE STATUS OF SENSOR
CONVEYER 1 PLAYER OFF 2 PLAYER OFF ALL PLAYERS EXIT	OFF/ON (DISPLAY OF OPERATION STAUS)	TEST THE MOVEMENT OF CONVEYER TICKET FND : DISPLAYS THE STATUS OF SENSOR
TICKET 1 PLAYER OFF 2 PLAYER OFF EXIT	OFF/ON (DISPLAY OF OPERATION STAUS)	TEST THE MOVEMENT OF TICKET DISPENSER ON TESTING, THIS DISPENSES 3 TICKETS AND STOPS AUTOMATICALLY TICKET FND : THE NO. OF DISPENSED TICKETS
COIN 1 PLAYER OFF 2 PLAYER OFF EXIT	OFF/ON (DISPLAY OF OPERATION STAUS)	TEST OF COIN SELECTOR ON TESTING, CHECK POWER-ON/OFF OF COIN SELECTOR TICKET FND : THE NO. OF INSERTED COINS
COUNTER 1 PLAYER 0 0 2 PLAYER 0 0 EXIT	DISPLAY COUNTER SIGNAL	TEST COUNTER LEFT BUTTON : INCREASES 1 ON COIN COUNTER RIGHT BUTTON : INCREASES 1 ON TICKET COUNTER
SOUND	(REFER TO THE TABLE BELOW)	SOUND TEST
EXIT	EXIT TO PREVIOUS MENU	

● TEST MODE -> INPUT TEST		
LCD DISPLAY		DESCRIPTION
1P	INPUT TEST	2P
000000		000000
00000000	0	00000000
00000000		00000000
00000000		00000000
DESCRIPTION (1P, 2P INPUT TEST IS SAME AS 1P INPUT TEST.)		
000000	1. COIN SENSOR 2. BILL SENSOR 3. TICKET SENSOR 4. TICKET BUTTON 5. 1P RESET BUTTON 6. 2P RESET BUTTON	
00000000	1. START BUTTON 2. CONVEYER SENSOR 3. CARD OUT SENSOR 4. PUSHER SENSOR 5. COUNTER HOPPER SENSOR 6. ELEVATOR HOPPER SENSOR 7. CARD DISPENSER SENSOR 8. CIRCULATION WIPER SENSOR	
00000000	1. CIRCULATION TOP SENSOR 2. CIRCULATION 1 SENSOR 3. CIRCULATION 2 SENSOR 4. CIRCULATION 3 SENSOR 5. CIRCULATION 3 SENSOR 6. CIRCULATION 4 SENSOR 7. CIRCULATION 5 SENSOR 8. CIRCULATION 6 SENSOR	
00000000	1. DIP SWITCH_1 2. DIP SWITCH_2 3. DIP SWITCH_3 4. DIP SWITCH_4 5. DIP SWITCH_5 6. DIP SWITCH_6 7. DIP SWITCH_7 8. DIP SWITCH_8	

● TEST MODE -> SOUND			
LCD DISPLAY		CONFIGURATION	EXPLANATION
CHANNEL	STOP	1	1 ~ 8
SOUND	1	STOP AUTO	AUTO 1 ~ 88
EXIT		EXIT TO SOUND TEST	

● PLAYFIELD-SETUP

◇ ON FIRST SETTING UP THE MACHINE AT A LOCATION, EXECUTE TABLE SET WITH SUPPLIED TOKENS FILLED IN THE ELEVATOR HOPPER

LCD DISPLAY	DESCRIPTION	PERFORM
TABLE SET. A	ON FIRST SETTING UP THE MACHINE A LOCATION (REFER TO TABLE 7)	PUSH SELECT BUTTON AND PERFORM
TABLE SET. B	ON ROUTINE TESTING THE MACHINE. (REFER TO TABLE 8)	
TABLE SET. C	ON ROUTINE TESTING THE MACHINE. (REFER TO TABLE 9)	
EXIT	RETURN TO PREVIOUS MENU	

● PLAYFIELD-SETUP -> TABLE SET. A PERFORM

◇ ON FIRST SETTING UP THE MACHINE AT A LOCATION, EXECUTE TABLE SET. A AS BELOW.

- ① FILL 1,000 TOKENS IN EACH ELEVATOR HOPPER
- ② ENTER TABLE SET A AND SELECT 1P, 2P
- ③ 1,000 TOKENS ARE AUTOMATICALLY LAUNCHED
- ④ WHEN 900 TOKENS ARE LAUNCHED, PUSHER TABLE TOKENS ARE READY TO PLAY

LCD DISPLAY	DESCRIPTION	PERFORM
PUSHER TABLE SET. A 1 PLAYER STOP 2 PLAYER STOP ALL PLAYERS	SELECT AND PERFORM PERFORM ONLY 1P PERFORM ONLY 2P PERFORM 1P, 2P	PUSH SELECT BUTTON AND PERFORM
EXIT	RETURN TO PREVIOUS MENU	

● PLAYFIELD-SETUP -> TABLE SET. B PERFORM

◇ ROUTINE FUNCTION TEST ON MANUFACTURING (AGING TEST)

3,000 PLAYS ARE AUTOMATICALLY PERFORMED WITH CARDS/TICKETS DISPENSED

LCD DISPLAY	DESCRIPTION	PERFORM
PUSHER TABLE SET. B 1 PLAYER STOP 2 PLAYER STOP ALL PLAYERS	SELECT AND PERFORM PERFORM ONLY 1P PERFORM ONLY 2P PERFORM 1P, 2P	PUSH SELECT BUTTON AND PERFORM
BOOKKEEPING	CHECK INTERNAL DATA DURING PERFORMING TABLE SET. B (REFER TO BOOKKEEPING DATA 1 BELOW)	
EXIT	RETURN TO PREVIOUS MENU	

● PLAYFIELD-SETUP -> TABLE SET. C PERFORM

◇ ROUTINE FUNCTION TEST ON MANUFACTURING (LONG-TERM AGING TEST)
 100,000PLAYS ARE AUTOMATICALLYPERFORMED WITH CARDS/TICKETS DISPENSED
 BUT, WHEN CARDS ARE NOT DISPENSED, ERROR CODE DOESN'T APPEAR

LCD DISPLAY	DESCRIPTION	PEFORM
PUSHER TABLE SET. C 1 PLAYER STOP 2 PLAYER STOP ALL PLAYERS	SELECT AND PERFORM PERFORM ONLY 1P PERFORM ONLY 2P PERFORM 1P, 2P	
BOOKKEEPING	CHECK INTERNAL DATA DURING PERFORMING TABLE SET. B (REFER TO BOOKKEEPINGDATA 1 BELOW)	
EXIT	RETURN TO PREVIOUS MENU	

● PLAYFIELD TEST DATA ON PLAYFIELD-SETUP

LCD DISPLAY	DESCRIPTION
---- CARD PER TOKENS --- 1 PLAYER: 50 2 PLAYER: 80	AVERAGETOKEN QTY PER DISPENSED CARD (TOTAL TOKEN QTY/ TOTAL DISPENSED CARD)
----- PLAY IN ----- 1 PLAYER: 20 2 PLAYER: 100	TOTAL PLAY QTY
----- TICKET OUT ----- 1 PLAYER: 730 2 PLAYER: 960	TOTAL TICKET OUT QTY
---- CARD DISPENSER ---- 1 PLAYER: 2 2 PLAYER: 4	TOTAL CARD OUT QTY FROM CARD DISPENSER
--- ELEVATOR HOPPER --- 1 PLAYER: 200 2 PLAYER: 400	TOTAL TOKEN-OUT QTY FROM ELEVATOR HOPPER

<p>---- COUNTER HOPPER ----</p> <p>1 PLAYER: 100</p> <p>2 PLAYER: 50</p>	TOTAL TOKEN-OUT QTY FROM COUNTER HOPPER.
<p>----- BONUS DROP1 -----</p> <p>1 PLAYER: 11</p> <p>2 PLAYER: 13</p>	THE TOTAL NO. OF BONUS DROP 1
<p>----- BONUS DROP2 -----</p> <p>1 PLAYER: 21</p> <p>2 PLAYER: 23</p>	THE TOTAL NO. OF BONUS DROP 2
<p>----- BONUS DROP3 -----</p> <p>1 PLAYER: 31</p> <p>2 PLAYER: 33</p>	THE TOTAL NO. OF BONUS DROP 3
<p>----- BONUS DROP4 -----</p> <p>1 PLAYER: 41</p> <p>2 PLAYER: 43</p>	THE TOTAL NO. OF BONUS DROP 4
<p>----- BONUS DROP5 -----</p> <p>1 PLAYER: 51</p> <p>2 PLAYER: 53</p>	THE TOTAL NO. OF BONUS DROP 5
<p>----- BONUS DROP6 -----</p> <p>1 PLAYER: 61</p> <p>2 PLAYER: 63</p>	THE TOTAL NO. OF BONUS DROP 6
<p>----- BONUS DROP7 -----</p> <p>1 PLAYER: 71</p> <p>2 PLAYER: 73</p>	THE TOTAL NO. OF BONUS DROP 7
<p>---- CIRCULATION DROP ----</p> <p>1 PLAYER: 11</p> <p>2 PLAYER: 13</p>	THE TOTAL NO. OF BONUS DROP (CENTER) IN CIRCULATION
<p>----- CIRCULATION 1 -----</p> <p>1 PLAYER: 21</p> <p>2 PLAYER: 23</p>	THE TOTAL NO. OF CIRCULATION FND 1
<p>----- CIRCULATION 2 -----</p> <p>1 PLAYER: 31</p> <p>2 PLAYER: 33</p>	THE TOTAL NO. OF CIRCULATION FND 2
<p>----- CIRCULATION 3 -----</p> <p>1 PLAYER: 41</p> <p>2 PLAYER: 43</p>	THE TOTAL NO. OF CIRCULATION FND 3
<p>----- CIRCULATION 4 -----</p> <p>1 PLAYER: 51</p> <p>2 PLAYER: 53</p>	THE TOTAL NO. OF CIRCULATION FND 4

----- CIRCULATION 5 ----- 1 PLAYER: 61 2 PLAYER: 63	THE TOTAL NO. OF CIRCULATION FND 5
----- CIRCULATION 6 ----- 1 PLAYER: 71 2 PLAYER: 73	THE TOTAL NO. OF CIRCULATION FND 6
CANCEL : RETURN TO PREVIOUS MENU.	

◆ **NOMAL LCD DISPLAY BEFORE ENTERING OPERATION MENU(MODE)**

BOOKKEEPING DATA		CONFIRM WITH [↑ ↓] BUTTON
LCD DISPLAY	DESCRIPTION	
---- CARD PER TOKENS --- 1 PLAYER: 50 2 PLAYER: 80	AVERAGE TOKEN QTY PER DISPENSED CARD (TOTAL TOKEN QTY/ TOTAL DISPENSED CARD)	
----- COIN IN ----- 1 PLAYER: 12 2 PLAYER: 25	TOTAL COIN IN. QTY	
----- BILL IN ----- 1 PLAYER: 1 2 PLAYER: 3	TOTAL BILL IN. QTY ACCUMULATED INPUT PULSE QTY	
----- SERVICE IN ----- 1 PLAYER: 5 2 PLAYER: 10	TOTAL SERVICE IN. QTY	
----- PLAY IN ----- 1 PLAYER: 20 2 PLAYER: 100	TOTAL PLAY QTY	
----- TICKET OUT ----- 1 PLAYER: 730 2 PLAYER: 960	TOTAL TICKET OUT QTY	
-- CARD DISPENSER -- 1 PLAYER: 2 2 PLAYER: 4	TOTAL CARD OUT QTY FROM CARD DISPENSER	
---- ELEVATOR HOPPER --- 1 PLAYER: 200 2 PLAYER: 400	TOTAL TOKEN-OUT QTY FROM ELEVATOR HOPPER	
---- COUNTER HOPPER ---- 1 PLAYER: 50 2 PLAYER: 100	TOTAL TOKEN-OUT QTY FROM COUNTER HOPPER	

[3. TROUBLESHOOTING]

*Common: Check the input voltage, check wiring

1. IN CASE OF POWER FAILURE

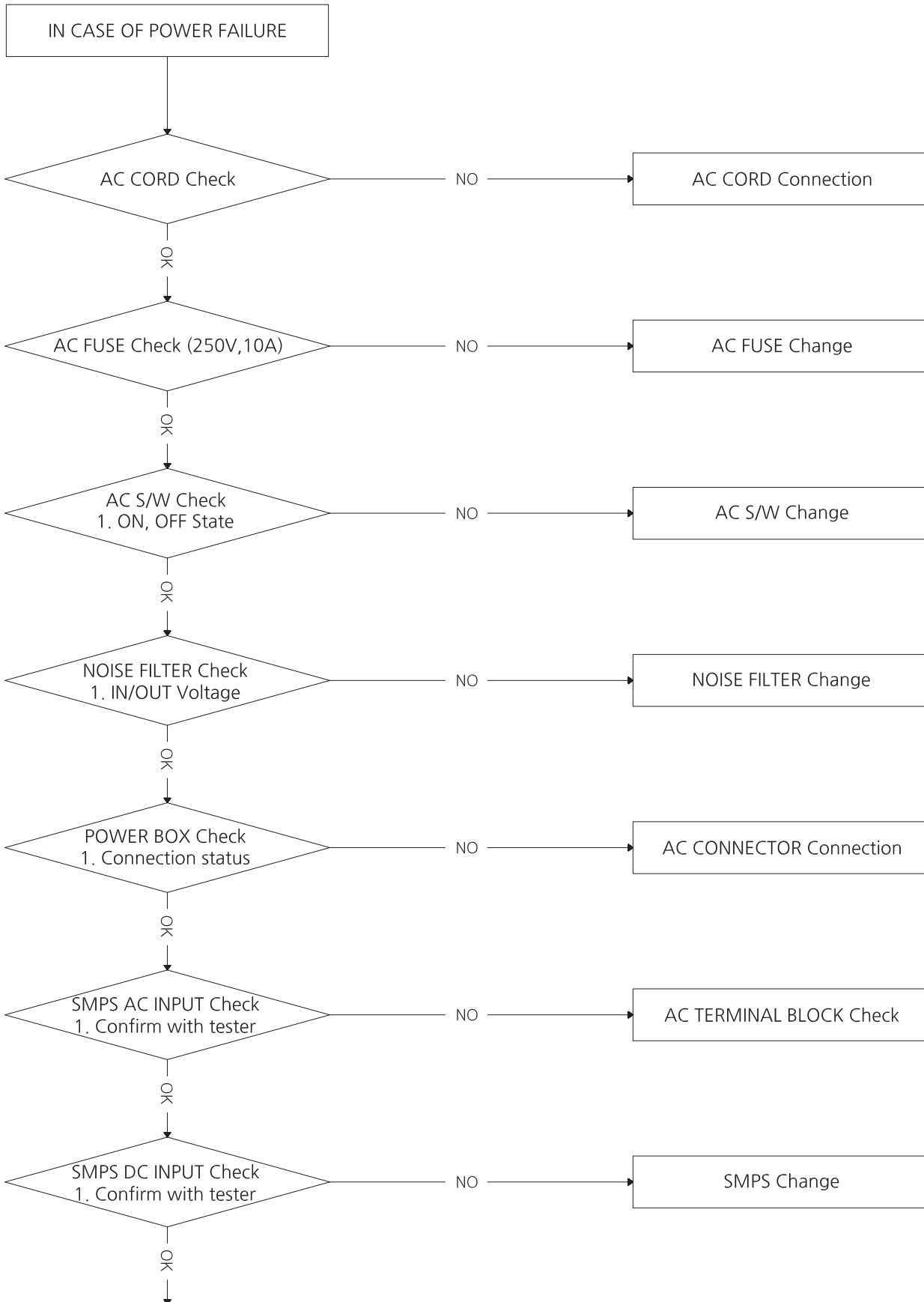

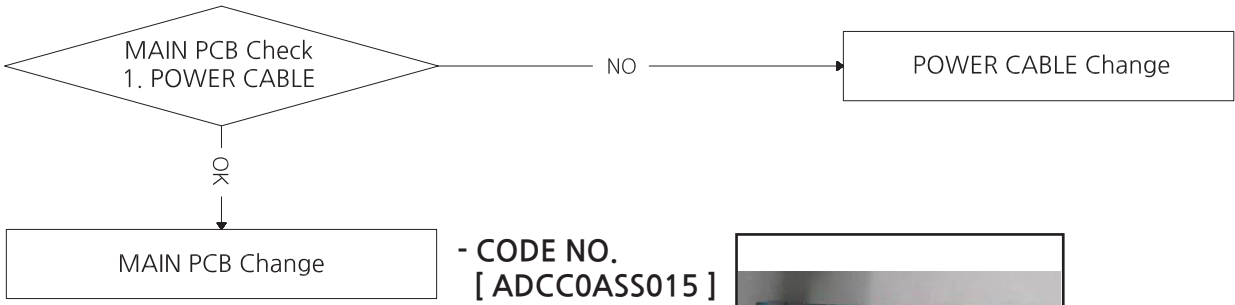

- CODE NO.
[ADCC0ASS015]



2. MEDAL CIRCULATION FND, CENTER FND PCB ERROR [1~2P]

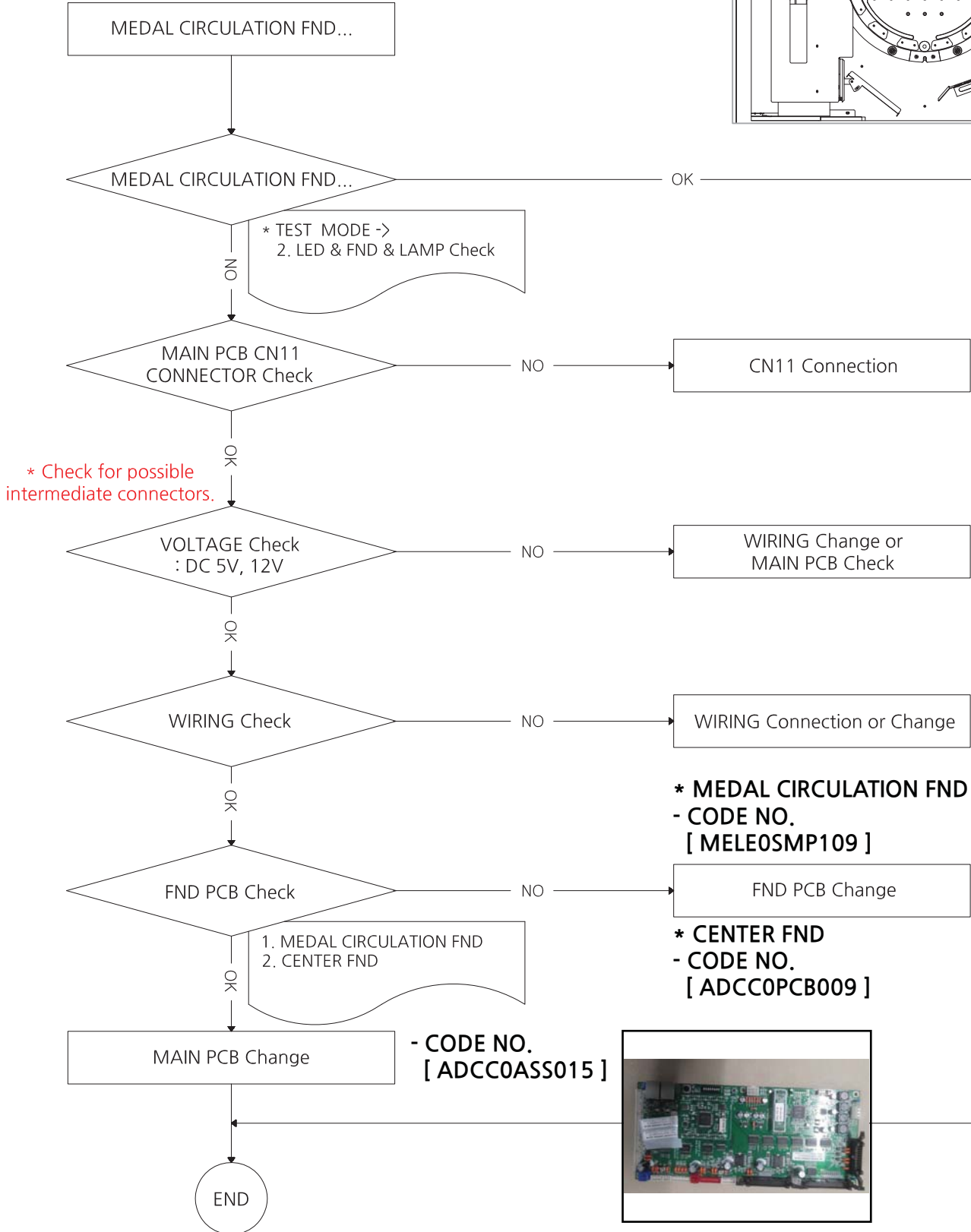
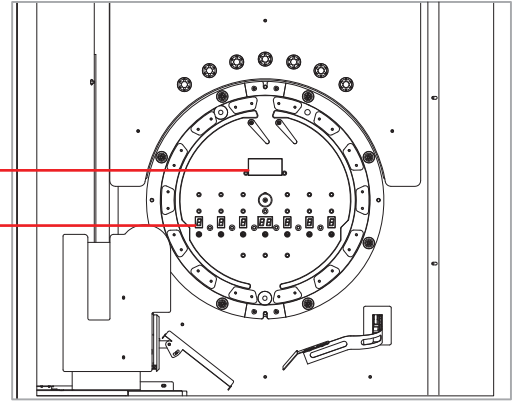

*** MEDAL CIRCULATION FND**
- CODE NO.
[MELE0SMP109]



*** CENTER FND**
- CODE NO.
[ADCC0PCB009]



3. TICKETS, TOKENS, BONUS FND PCB ERROR [1~2P]

TICKETS FND PCB
TOKENS FND PCB

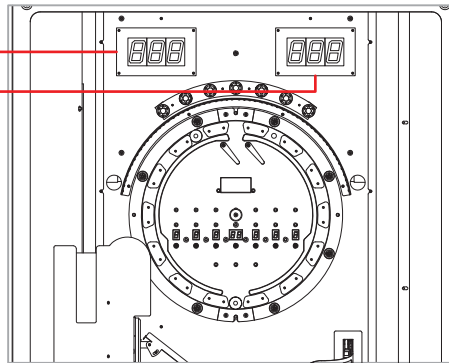

BONUS FND PCB

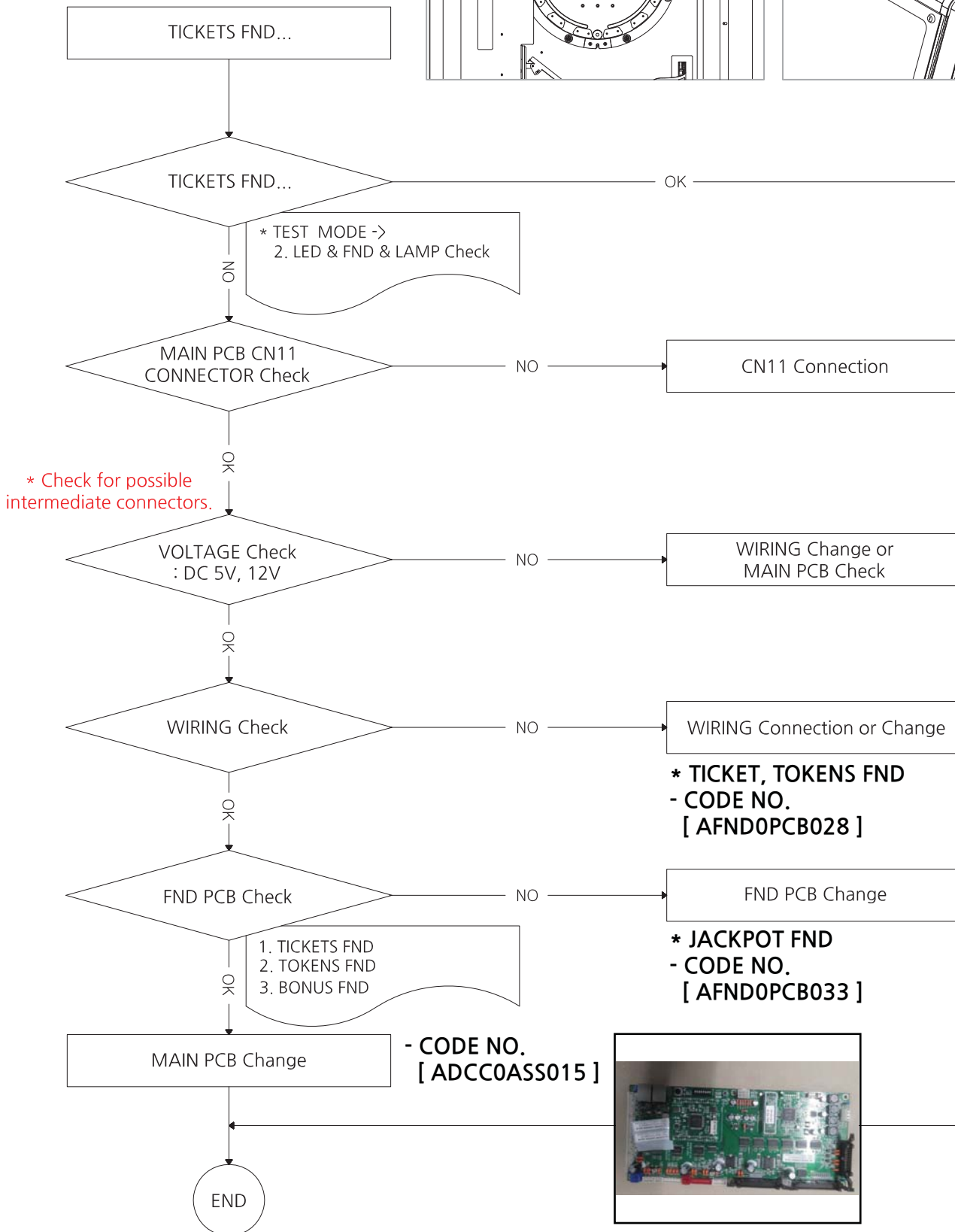
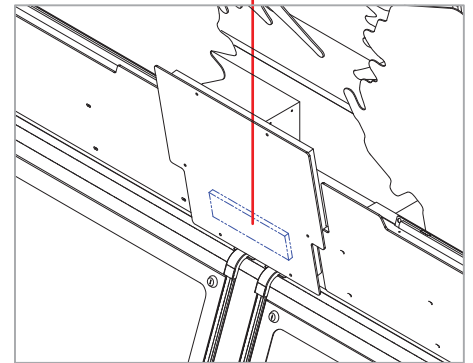

* TICKET, TOKENS FND
- CODE NO.
[AFND0PCB028]



* JACKPOT FND
- CODE NO.
[AFND0PCB033]



4. WHEEL SPIN LED PCB ERROR [1~2P]

WHEEL SPIN LED PCB

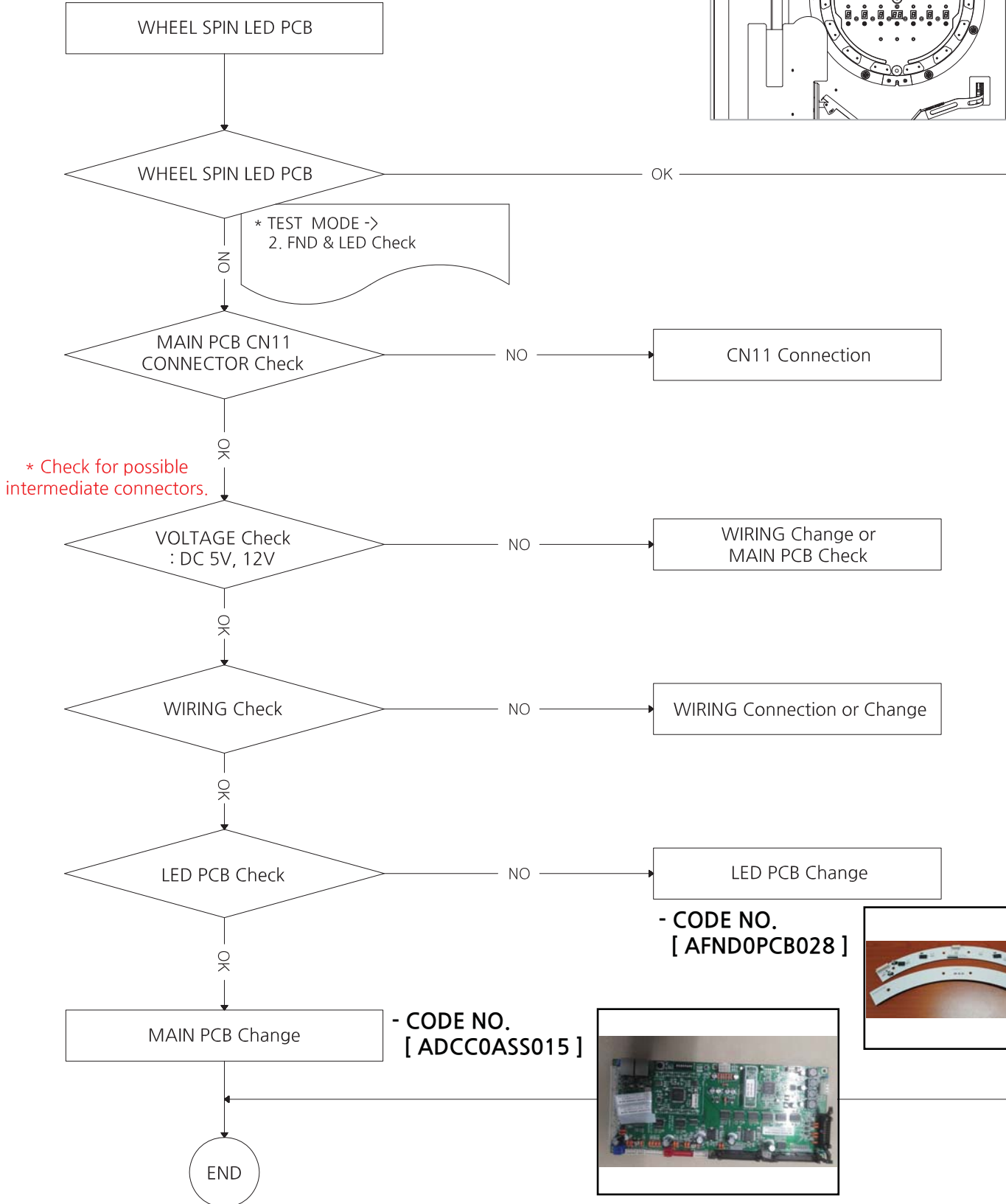
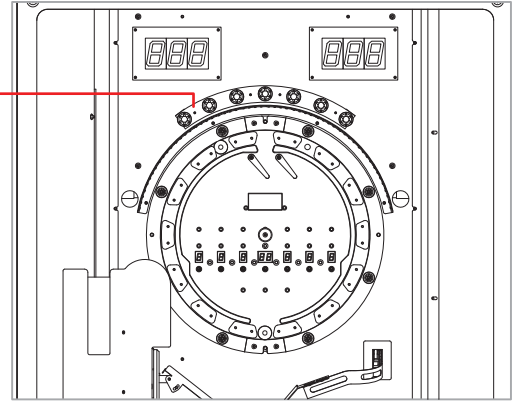

5. BUTTON LED PCB ERROR [1~2P]

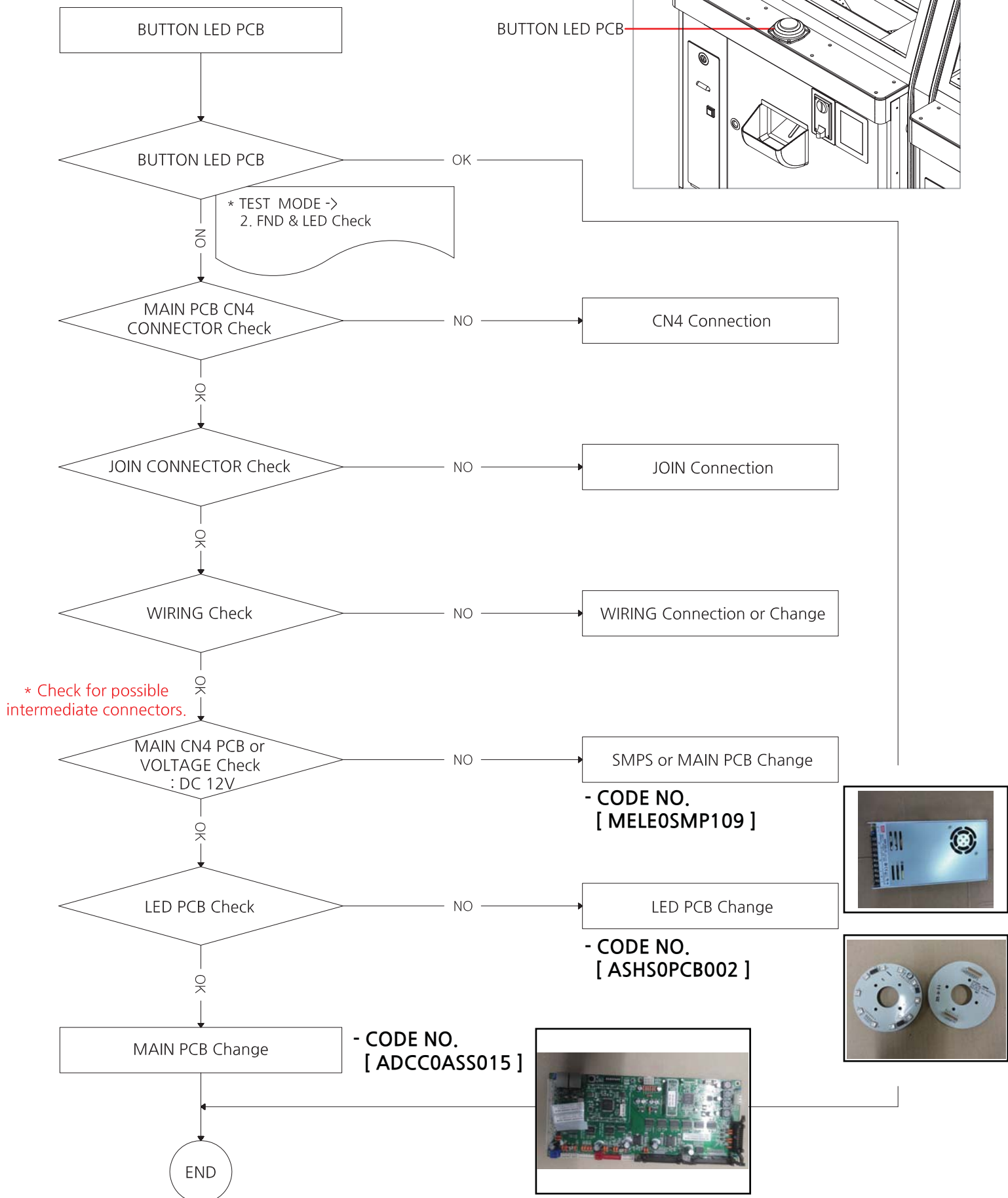

6. ARC FLEX LED, DOOR LED, TABLE LED, TOP LED ERROR [1~2P]

ARC FLEX LED

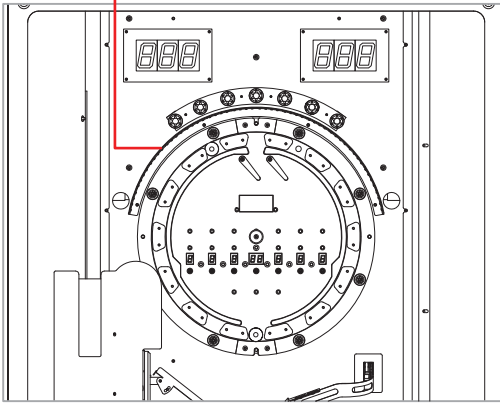
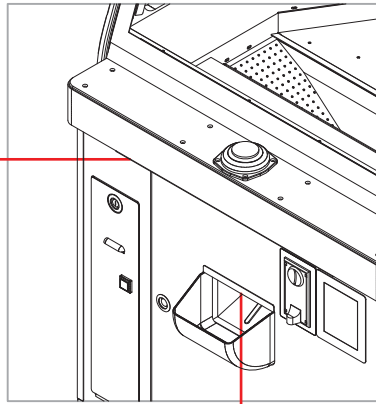
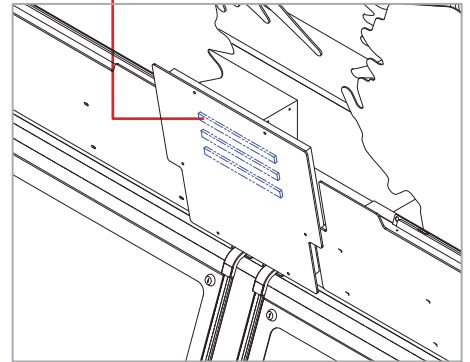

TABLE LED



TOP LED



DOOR LED

SPOT LED...

*** DOOR LED**
- CODE NO.
[AMUM0PCB005]

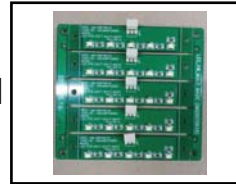

*** TOP LED**
- CODE NO.
[ADC20PCB001]

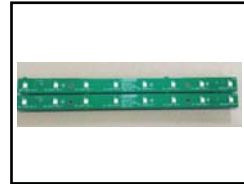

SPOT LED...

OK

* TEST MODE ->
2. FND & LED Check

SMPS CONNECTION Check

NO

SMPS Connection

OK

JOIN CONNECTION Check

NO

JOIN Connection

OK

WIRING Check

NO

WIRING Connection or Change

OK

* Check for possible
intermediate connectors.

LED PCB VOLTAGE Check
: DC 12V

NO

LED PCB Change

OK

* Check for possible intermediate connectors.

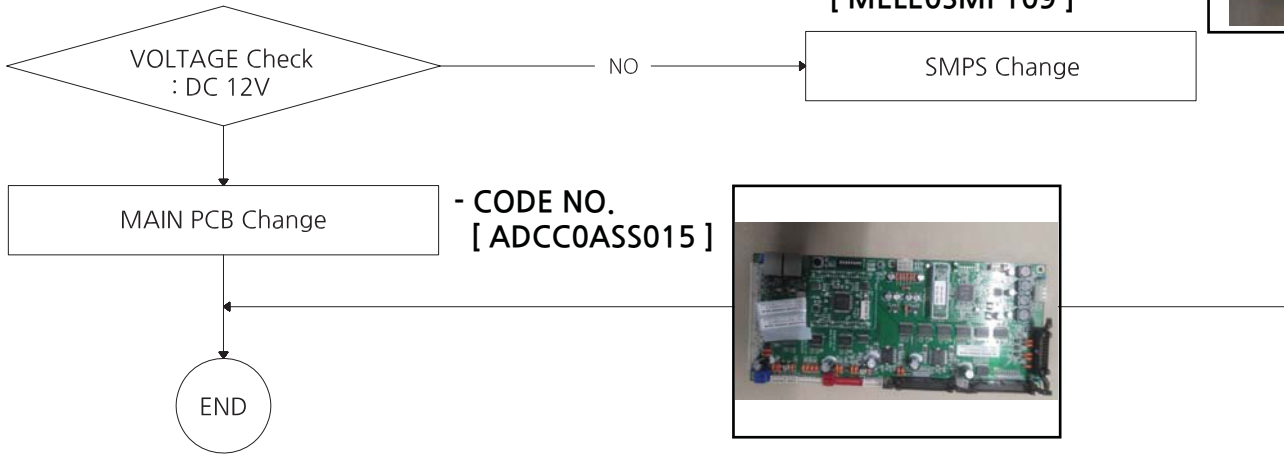

7. TICKET DISPENSER ERROR [1~2P]

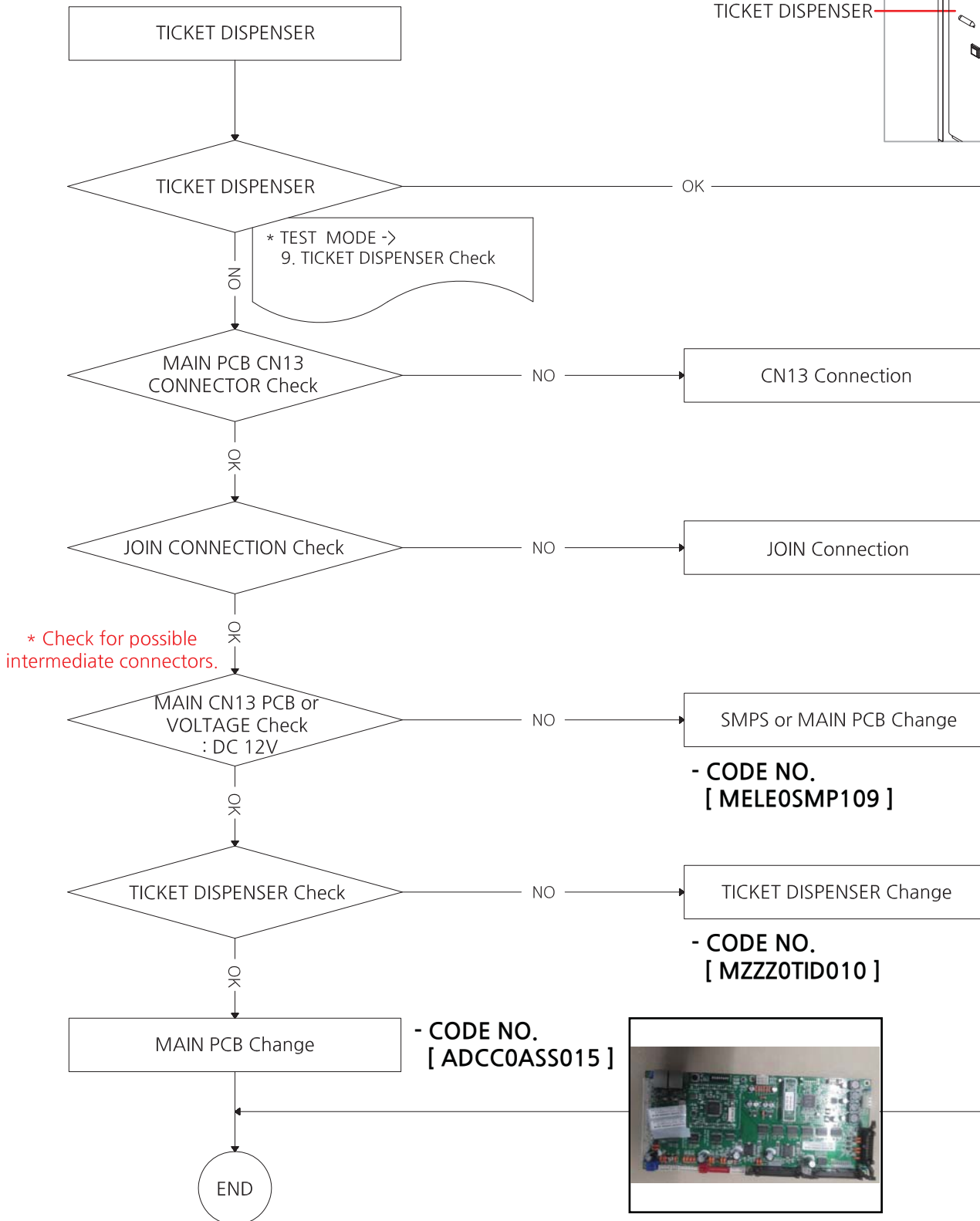
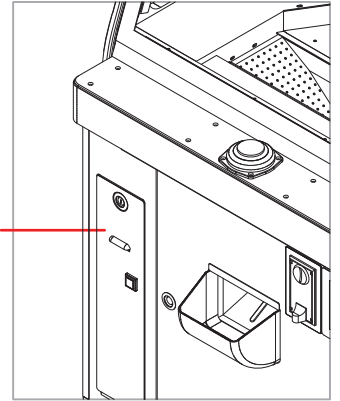

8. IN CASE OF MALFUNCTION OF PUSHER [1~2P] - ERROR 04

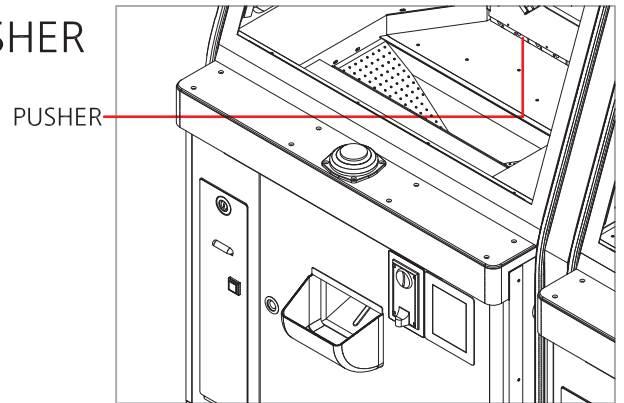

* CAUSE - COIN REMOVAL

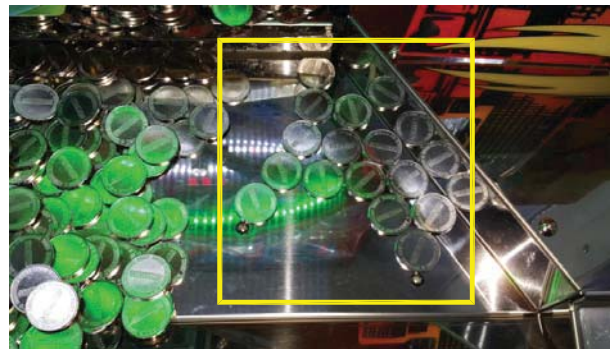
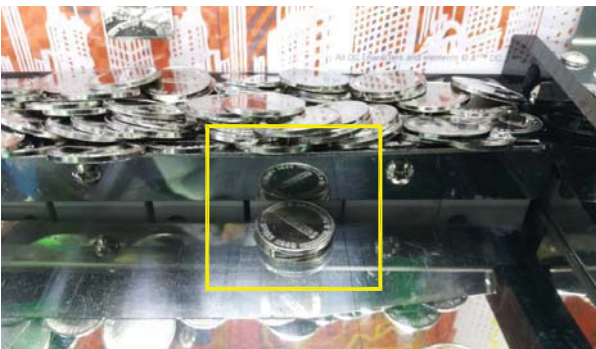

* If the error can not be cleared by resetting, unfold a coin of the screw of the PUSHER Plate and press the reset button.

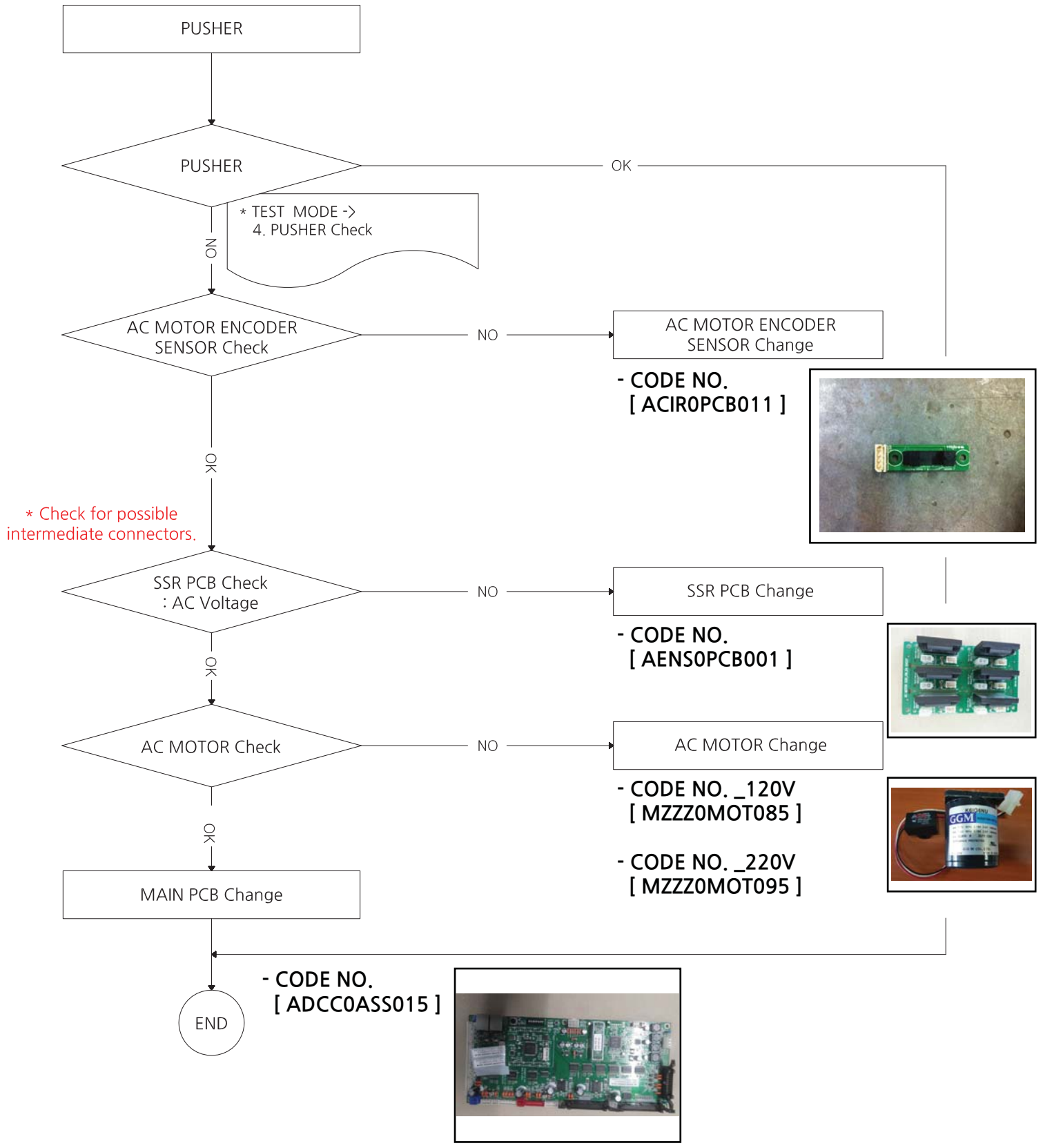

9. COUNTER HOPPER ERROR [1~2P] - ERROR 05

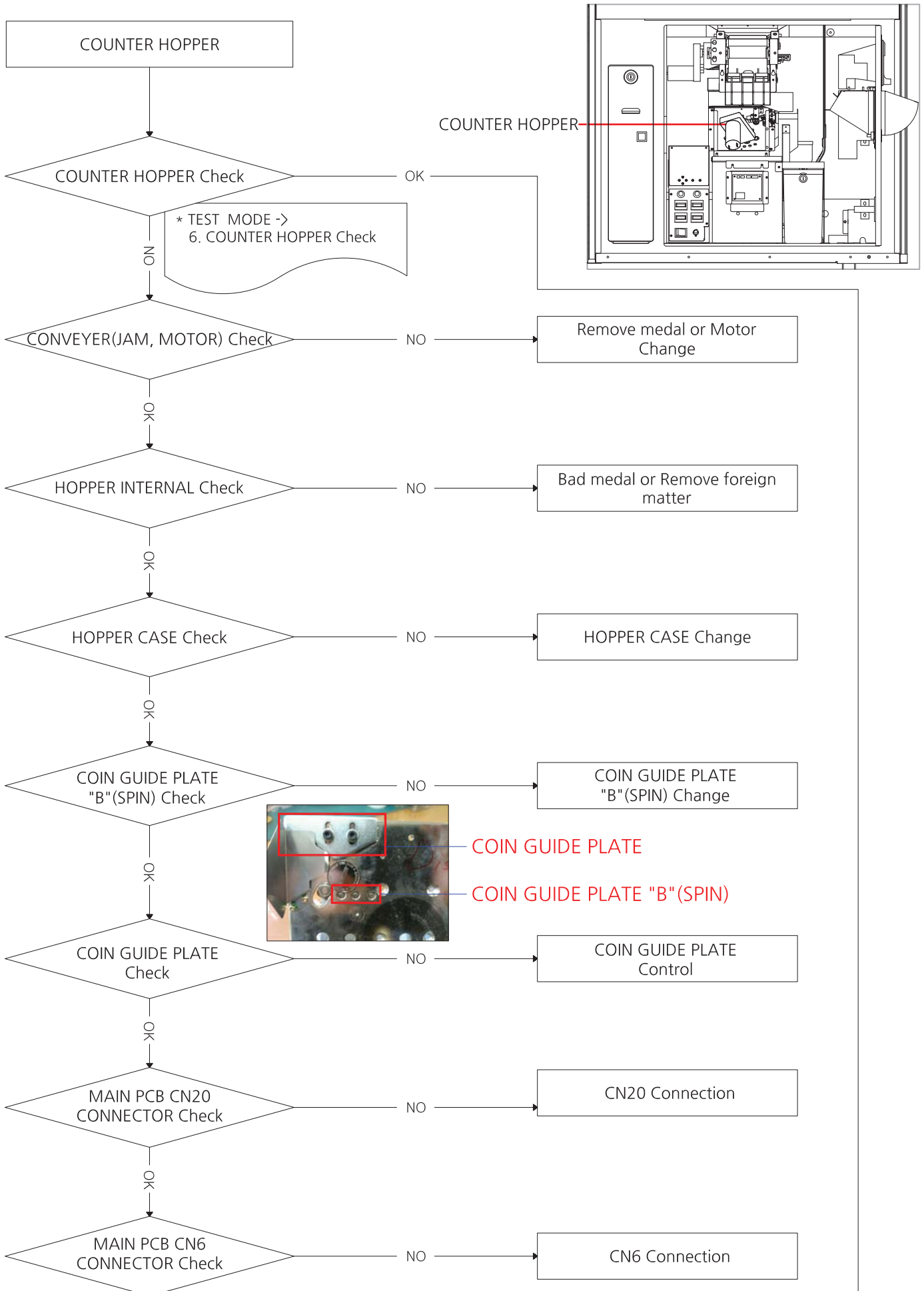



- CODE NO.
[MELE0SMP089]

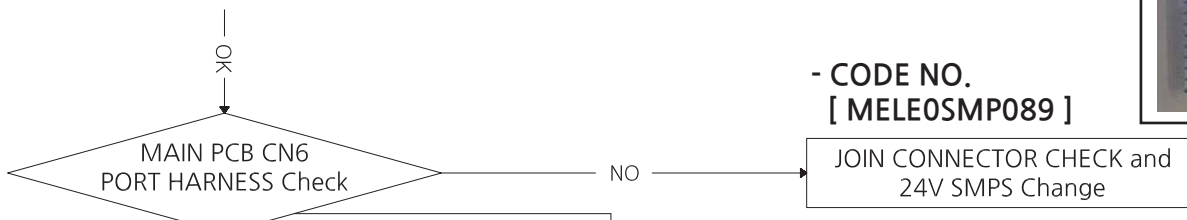

- CODE NO.
[ADCC0ASS015]

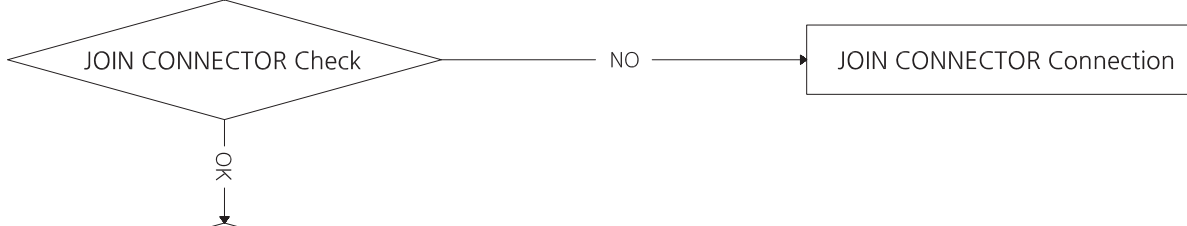
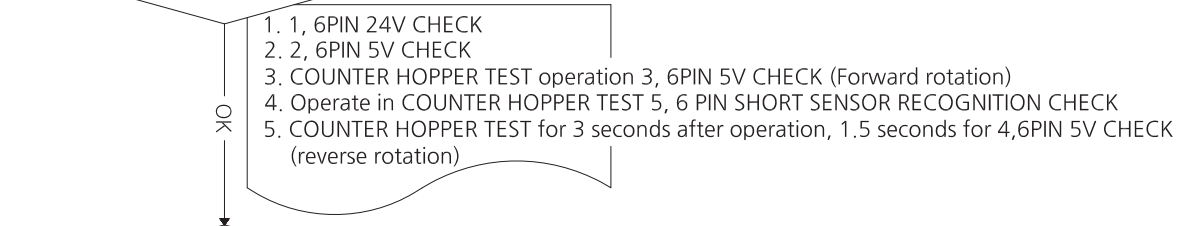
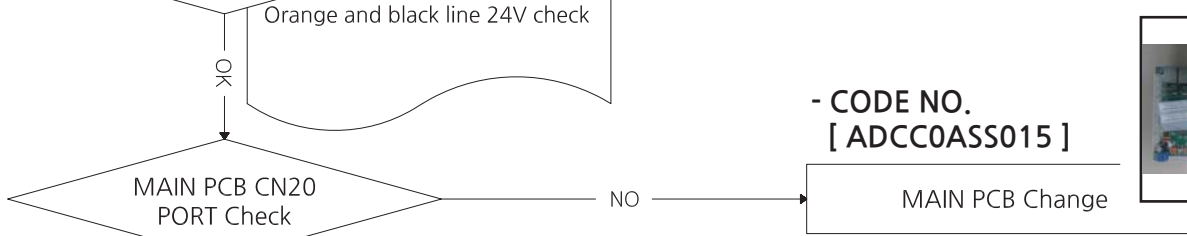

- CODE NO.
[AZZZ0PCB172]

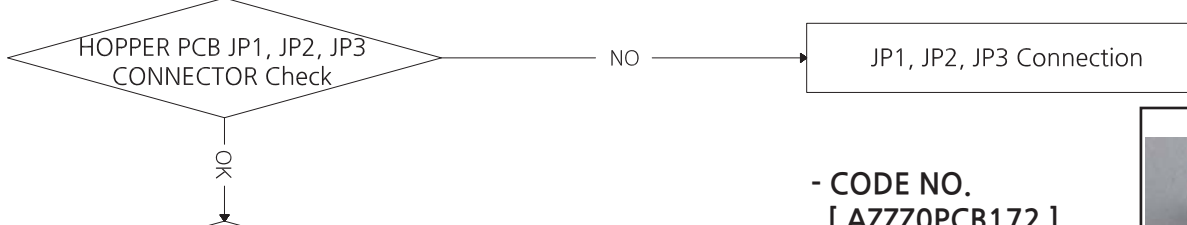

- CODE NO.
[AZZZ0PCB172]

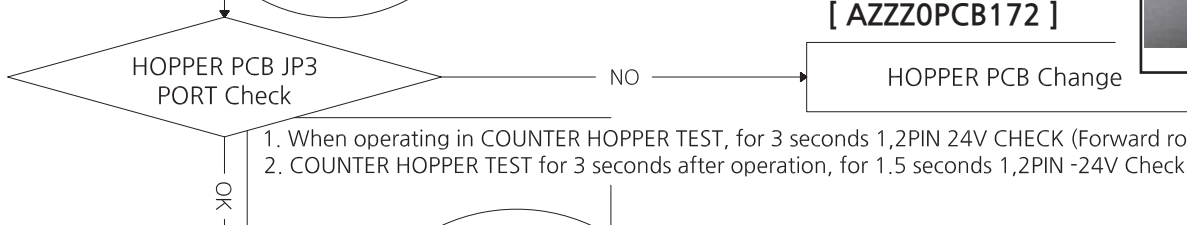
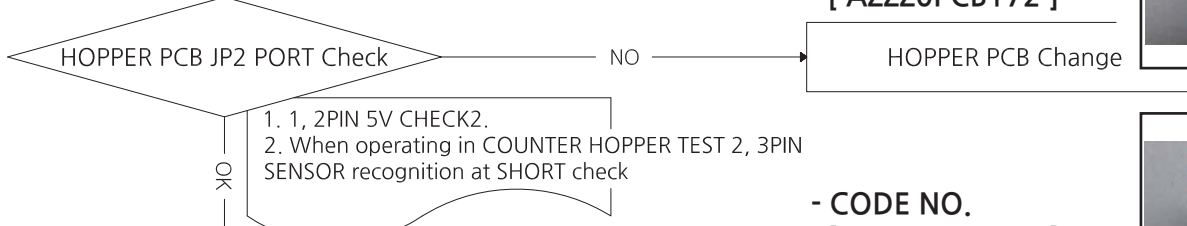

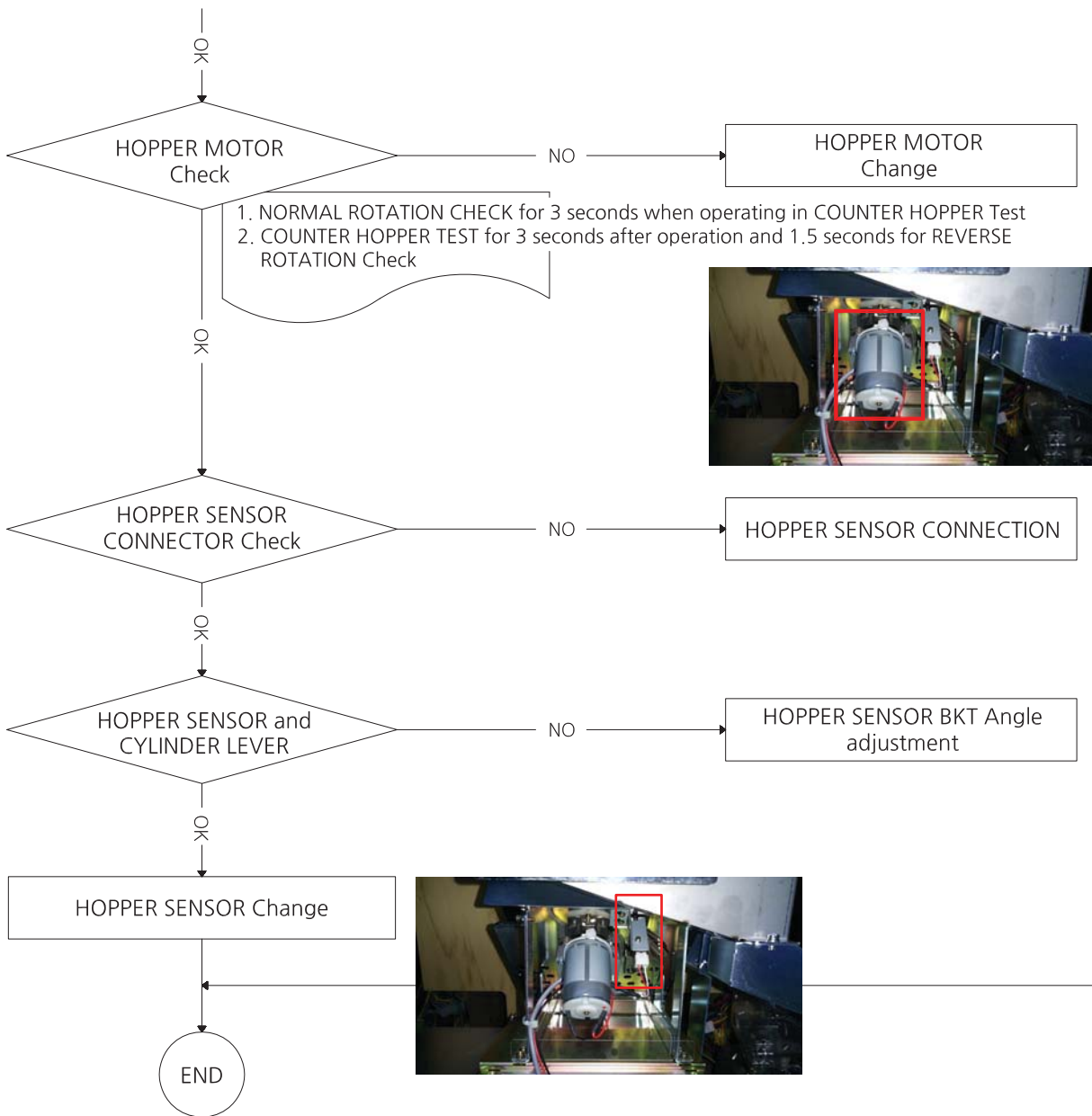

10. ELEVATOR HOPPER ERROR [1~2P] - ERROR 06

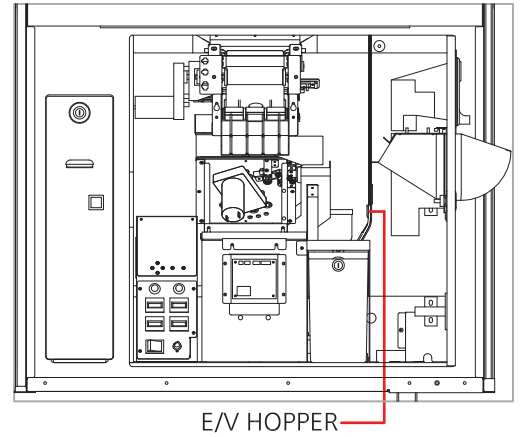

* CAUSE - LACK OF COIN or COIN JAM



* CAUSE - ELEVATOR RAIL COIN JAM

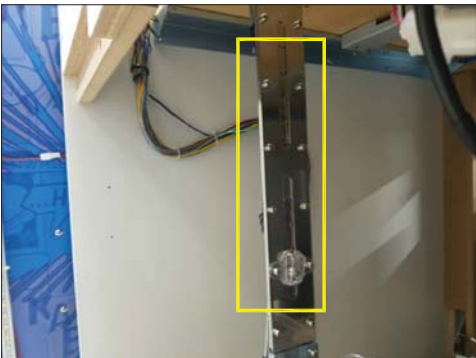

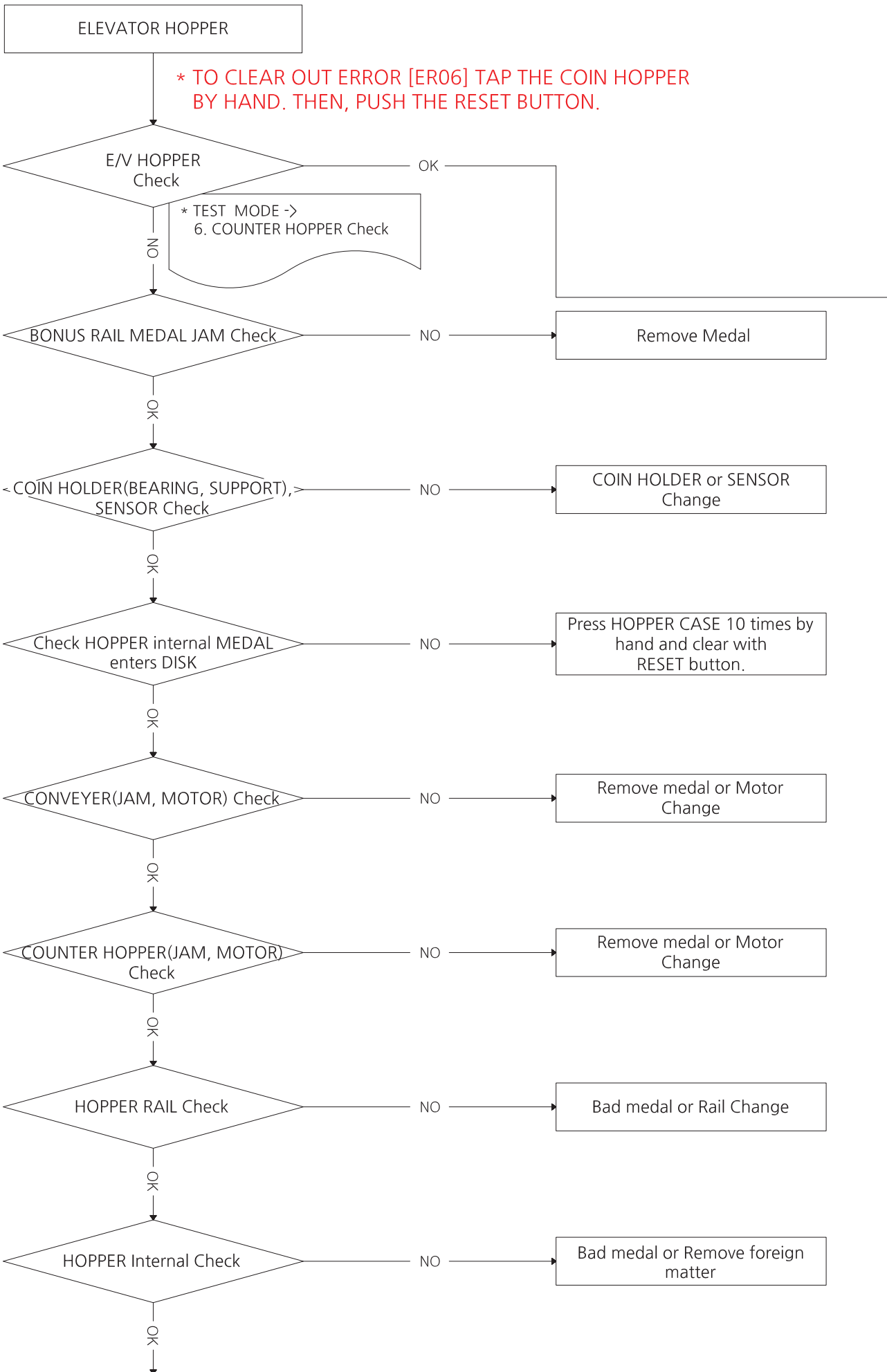

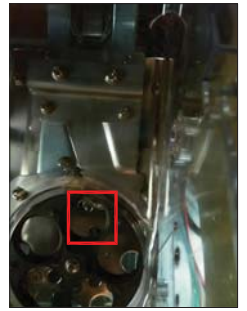
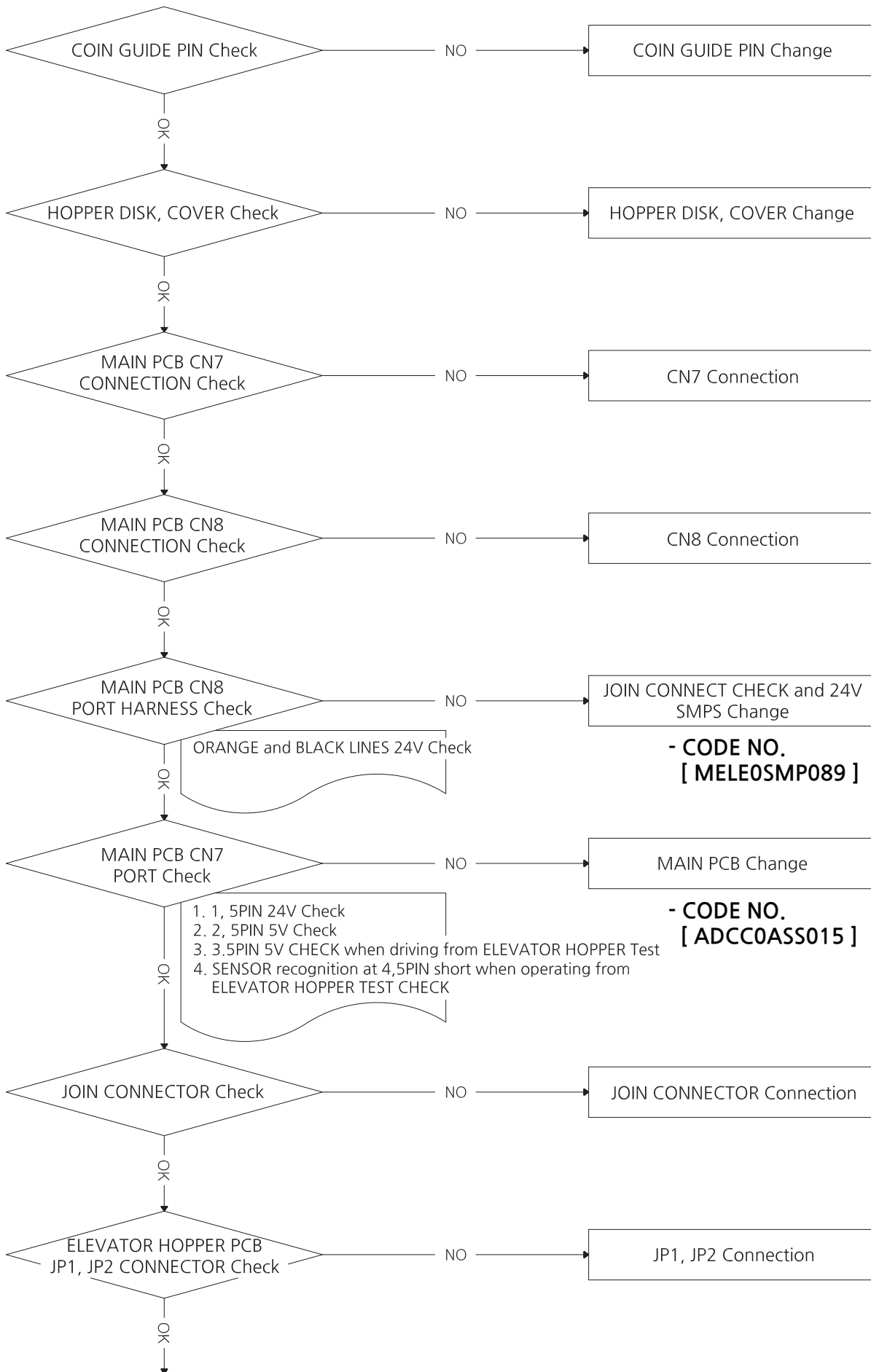

ORANGE and BLACK LINES 24V Check

JOIN CONNECT CHECK and 24V SMPS Change

- CODE NO. [MELE0SMP089]

MAIN PCB Change

- CODE NO. [ADCC0ASS015]

1. 1, 5PIN 24V Check
2. 2, 5PIN 5V Check
3. 3, 5PIN 5V CHECK when driving from ELEVATOR HOPPER Test
4. SENSOR recognition at 4,5PIN short when operating from ELEVATOR HOPPER TEST CHECK

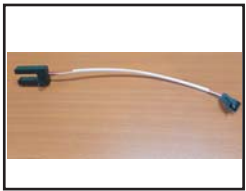

- CODE NO.
[AZZZ0PCB173]

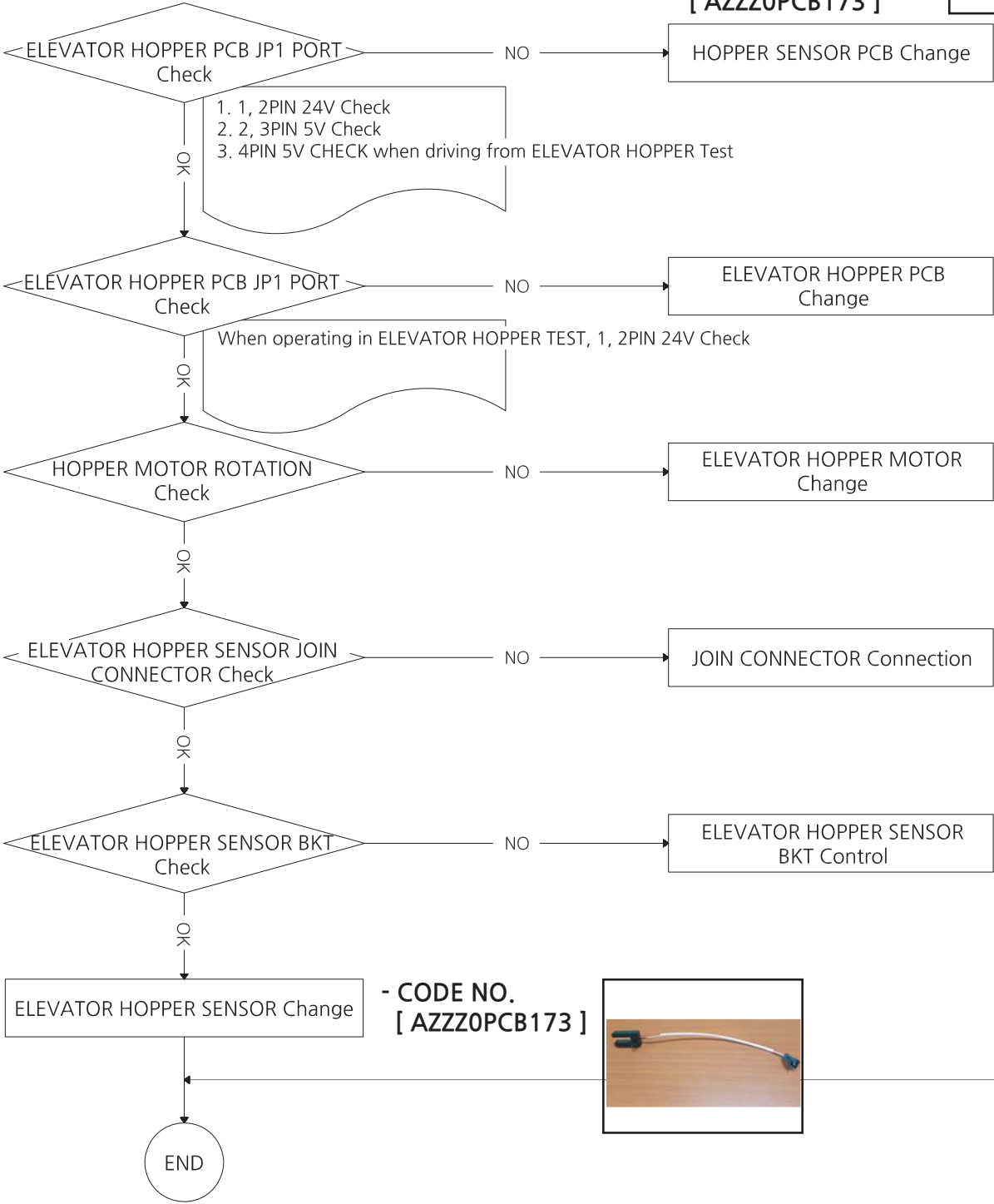

11. CIRCULATION WIPER ERROR [1~2P] - ERROR 07

* CAUSE - CIRCULATION WIPER MOTOR

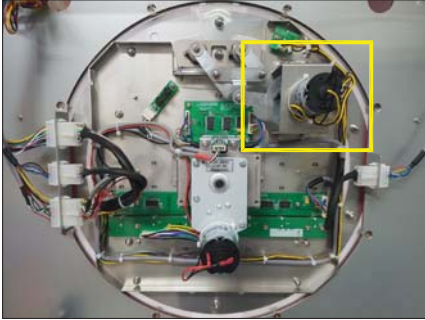

CIRCULATION WIPER

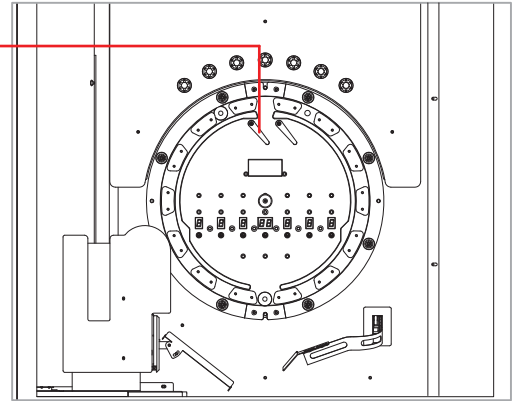

* CAUSE - CIRCULATION WIPER SNEOSR

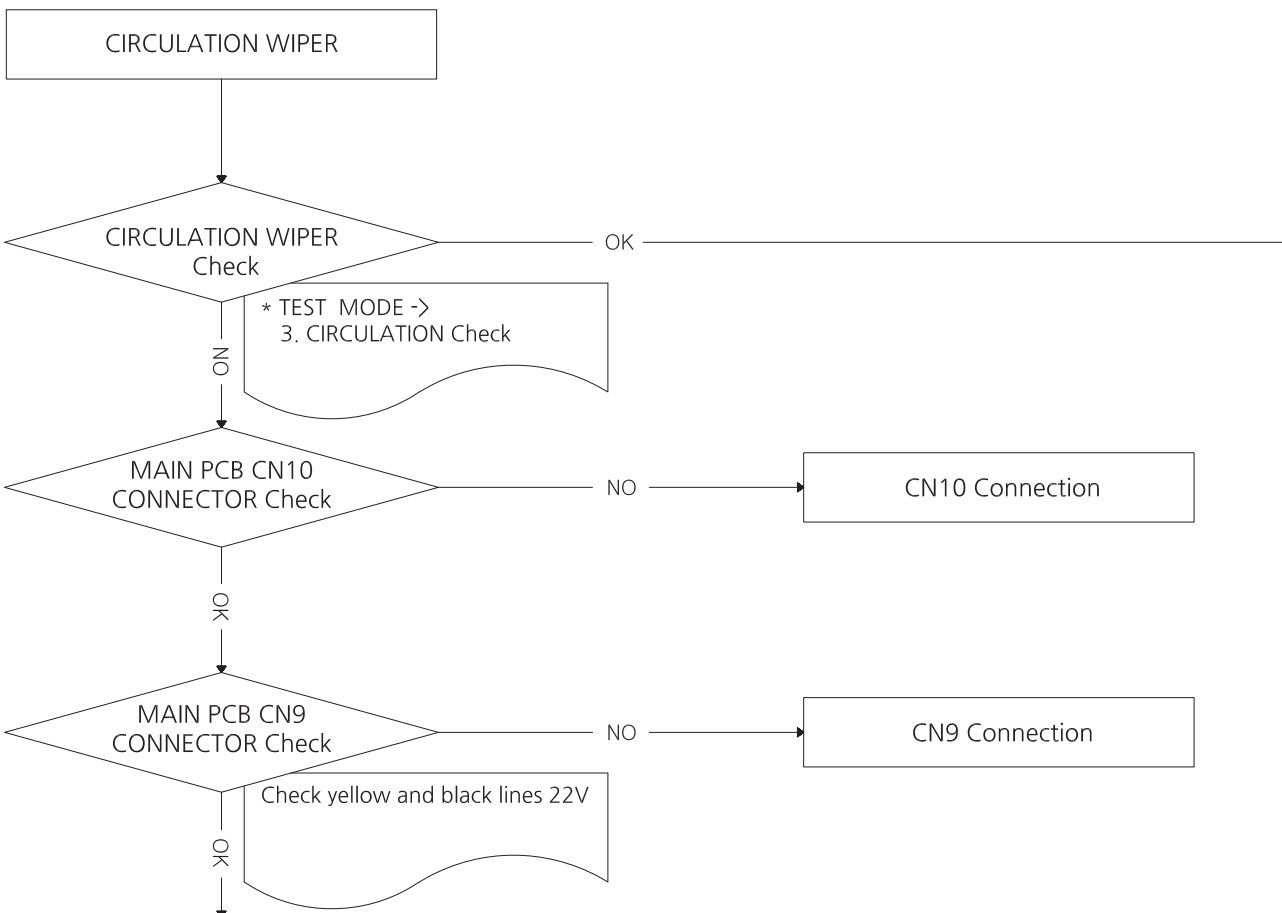
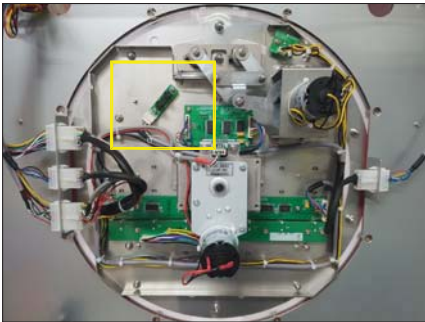



- CODE NO.
[MELE0SMP089]

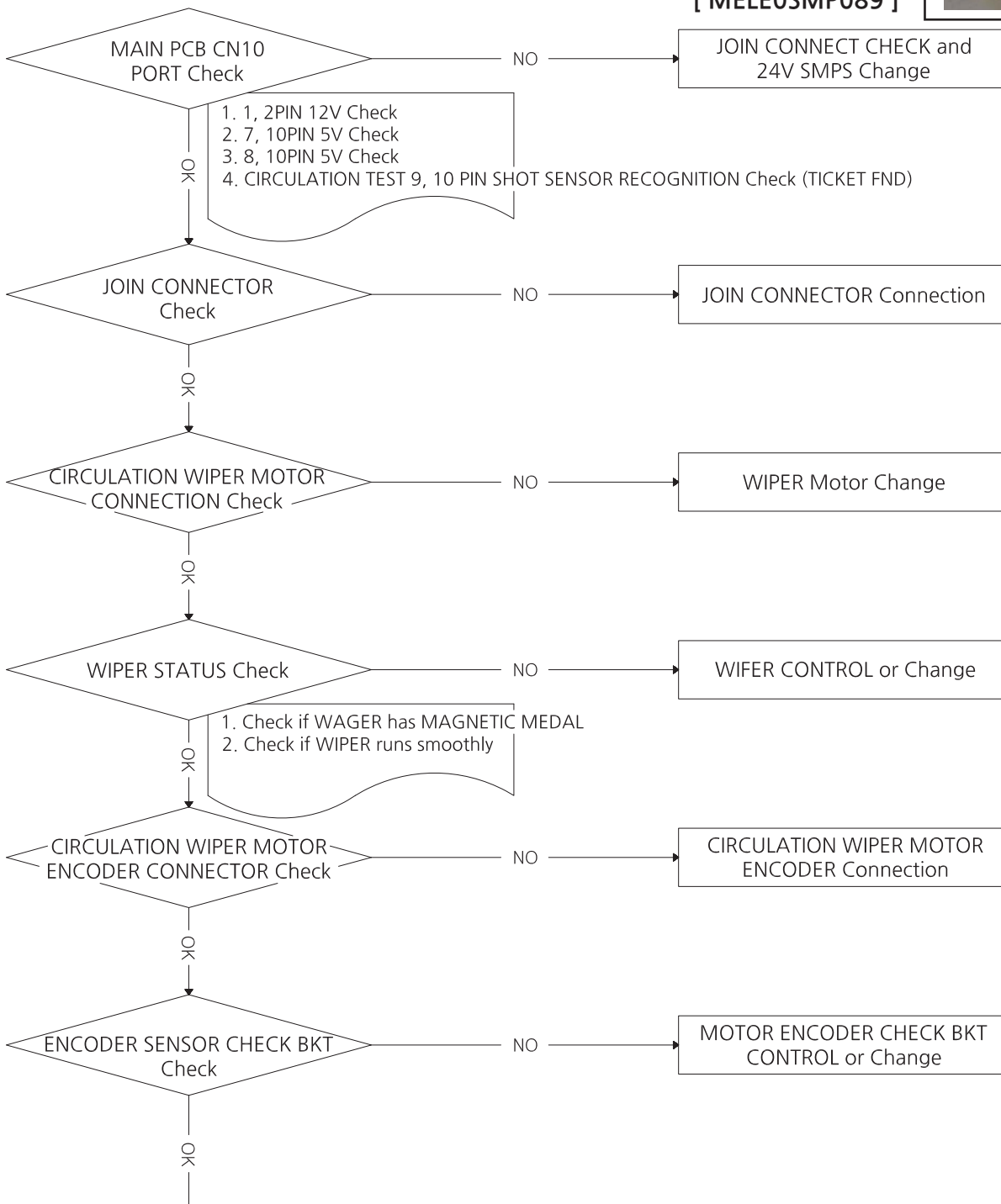

- CODE NO.
[AZZZ0PCB103]

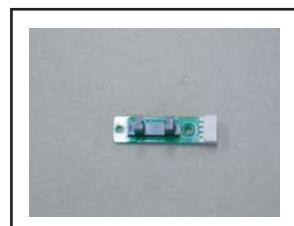

END

12. CIRCULATION ENCODER SENSOR ERROR [1~2P] - ERROR 09

* CAUSE - COIN JAM

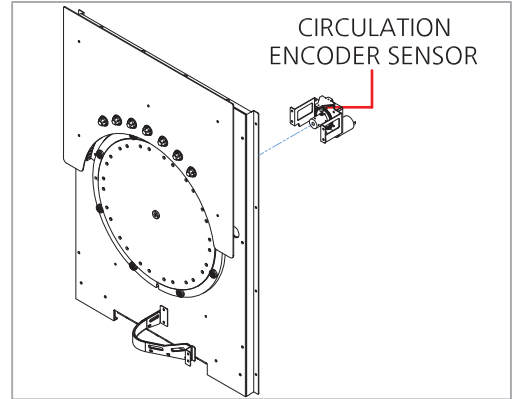

* CAUSE - CIRCULATION MOTOR

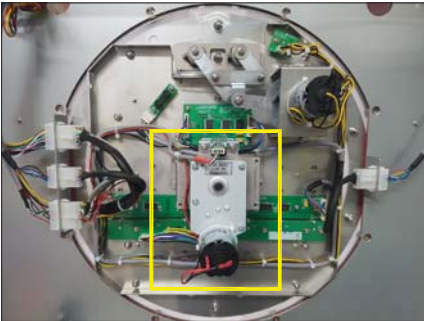

* CAUSE - CIRCULATION SENSOR

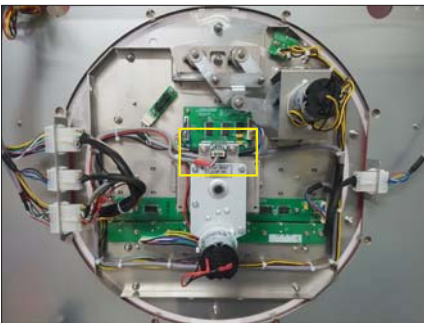

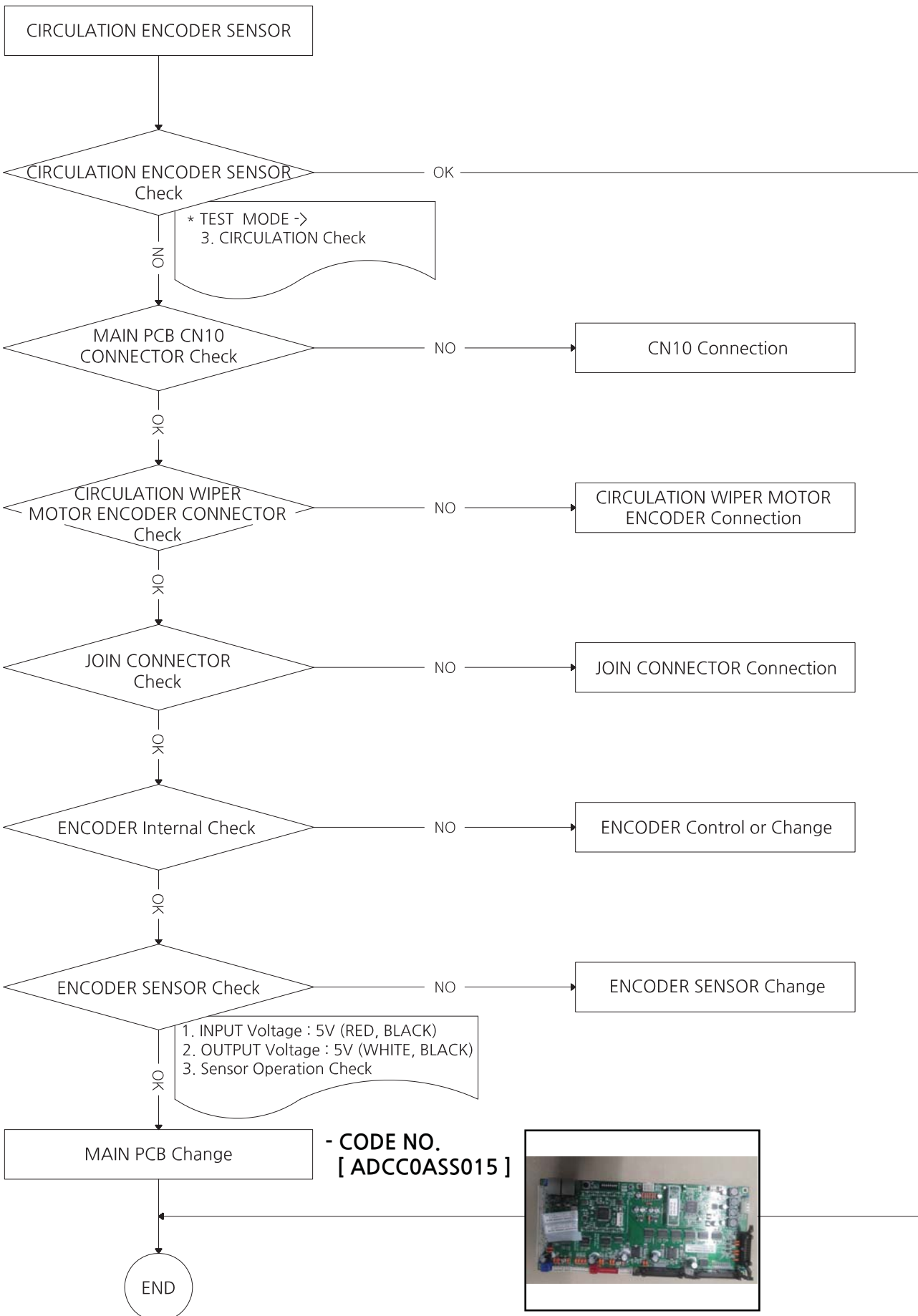

* WHEN THE MAGNET OF THE MAGNETIC COIN IS MISSING
- New purchase after removal

13. CIRCULATION MAGNETIC SENSOR PCB ERROR [1~2P] - ERROR 10 (MEDAL CIRCULATION CHECK-A PCB ASS'Y)

* CAUSE - MAGNETIC SENSOR PCB

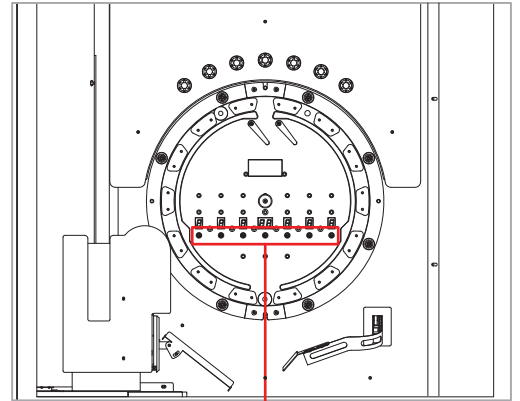
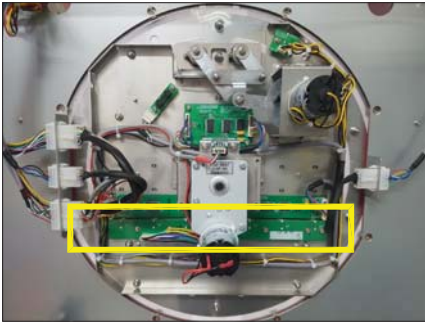

CIRCULATION MEDAL CHECK AREA [A]

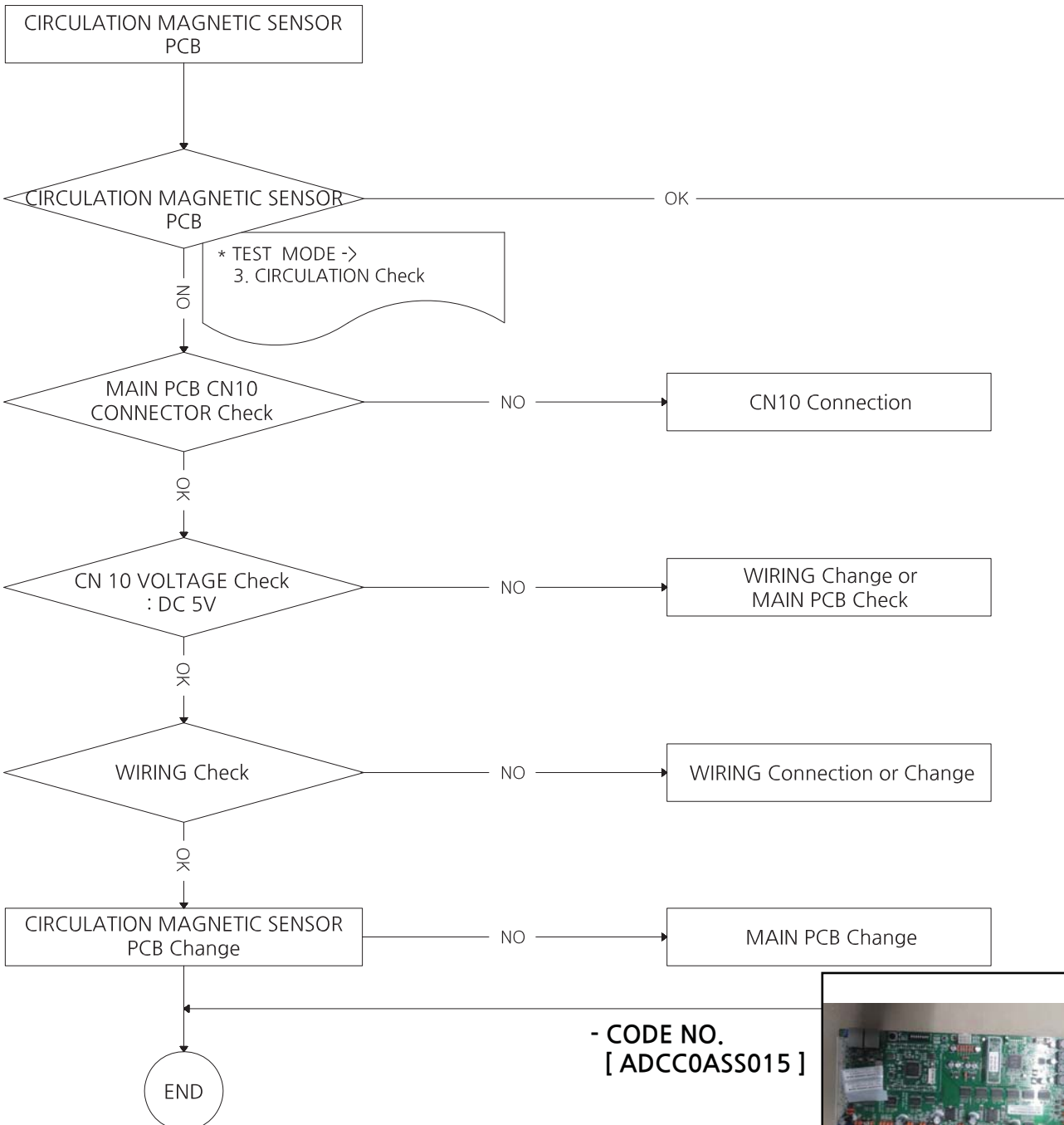

- CODE NO. [ADCC0ASS015]



14. CIRCULATION ERROR [1~2P] - ERROR 03

(MEDAL CIRCULATION CHECK-B PCB ASS'Y)

CIRCULATION MEDAL CHECK AREA [B]

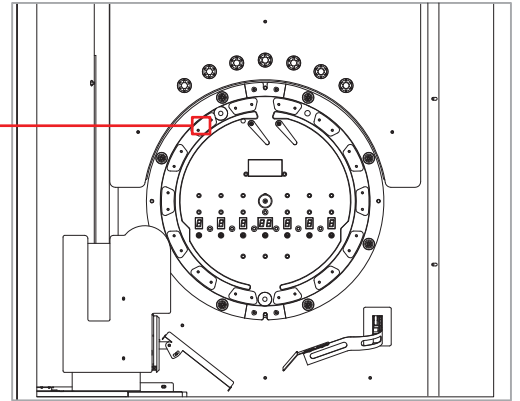

* CAUSE - MEDAL 8ea JAM



- Disable using magnet
- Tap and release
- Move down

* CAUSE - CIRCULATION SENSOR



* IF THE COIN IS PARTIALLY CAUGHT

- Remove the RING GUIDE by tapping it after removing it

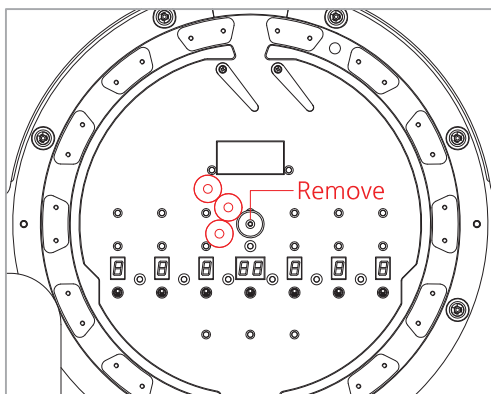

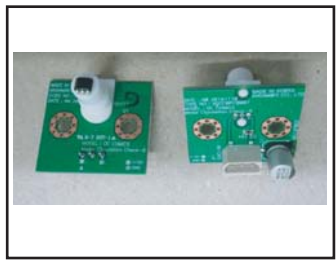
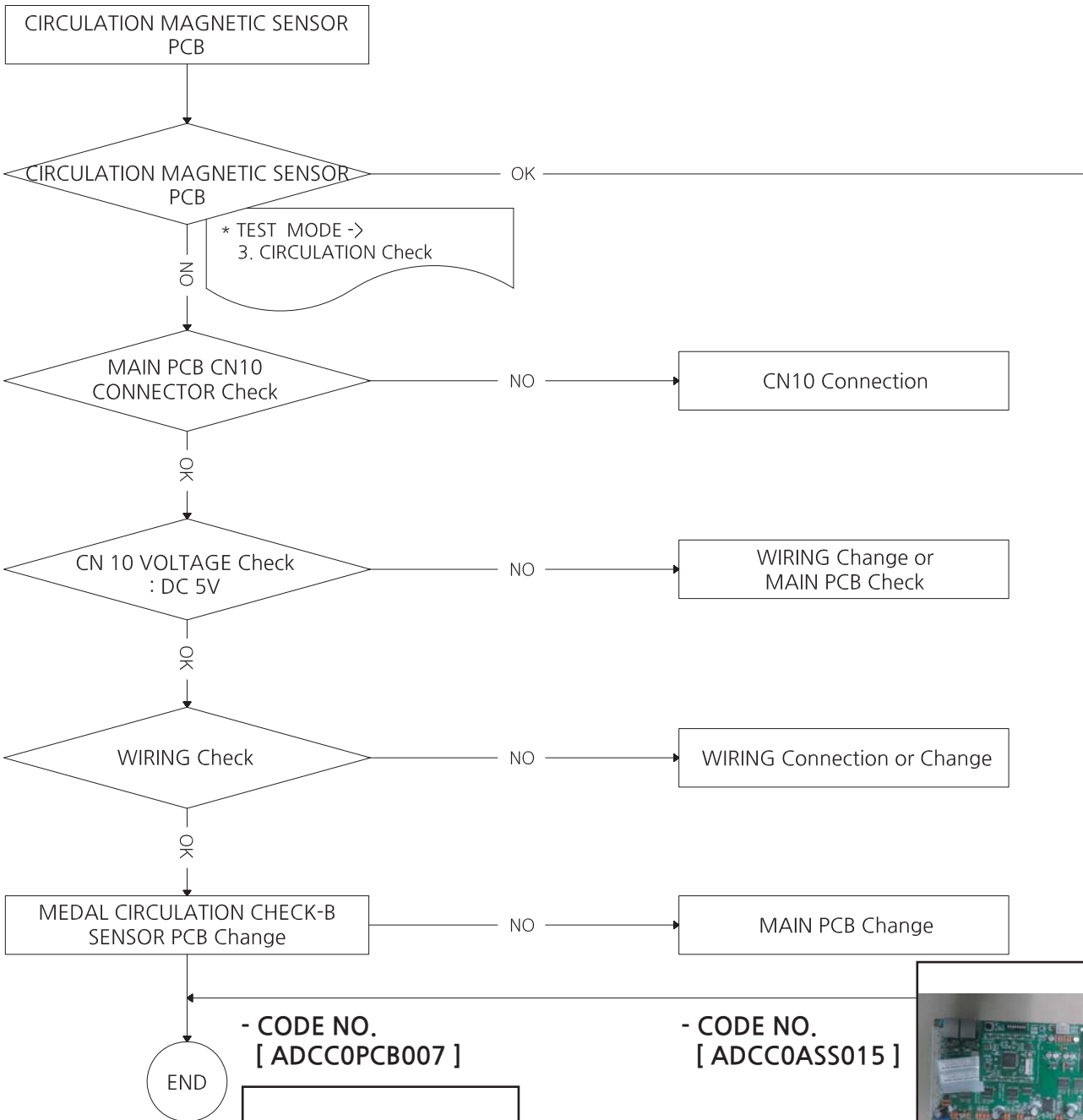

- CODE NO. [ADCC0ASS015]



15. CONVEYER ERROR [1~2P] - ERROR 08

CONVEYOR

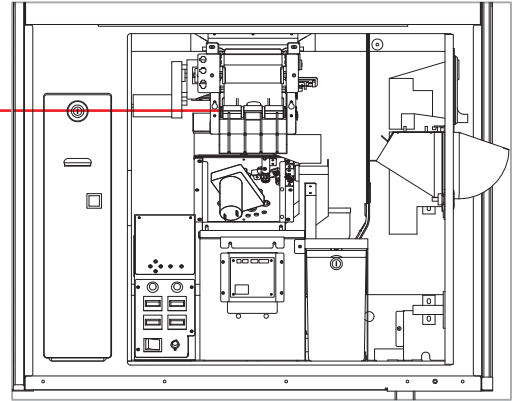

* CAUSE - COIN JAM



* CAUSE - CONVEYER MOTOR

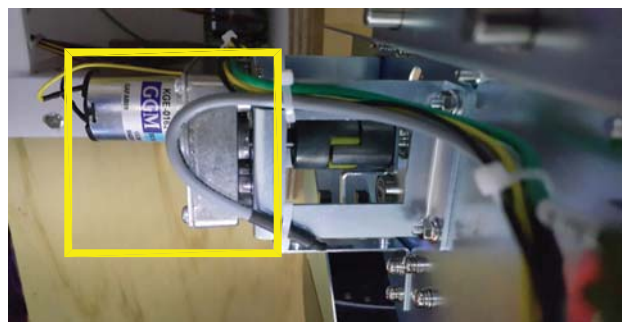

* CAUSE - CONVEYER BELT

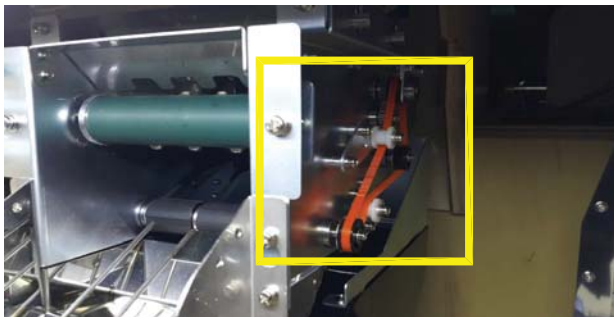

* CAUSE - CONVEYER SENSOR

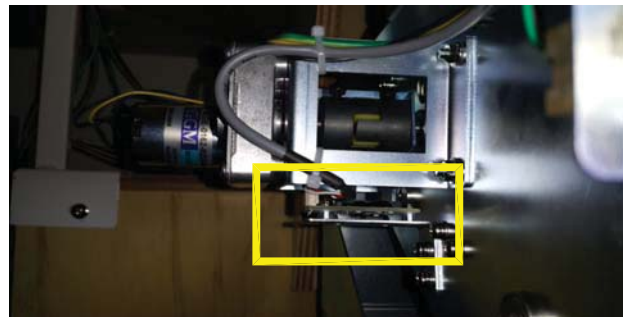

* HOW TO DISASSEMBLE CONVEYOR

- ① Removing screw 2EA
 - ② Separation of wiring 3EA
 - ③ Pull out the conveyor from the side 4EA shaft
 - ④ Assemble hinge to top of PAYOUT PANEL when reassembling.
- Reassemble them in reverse order

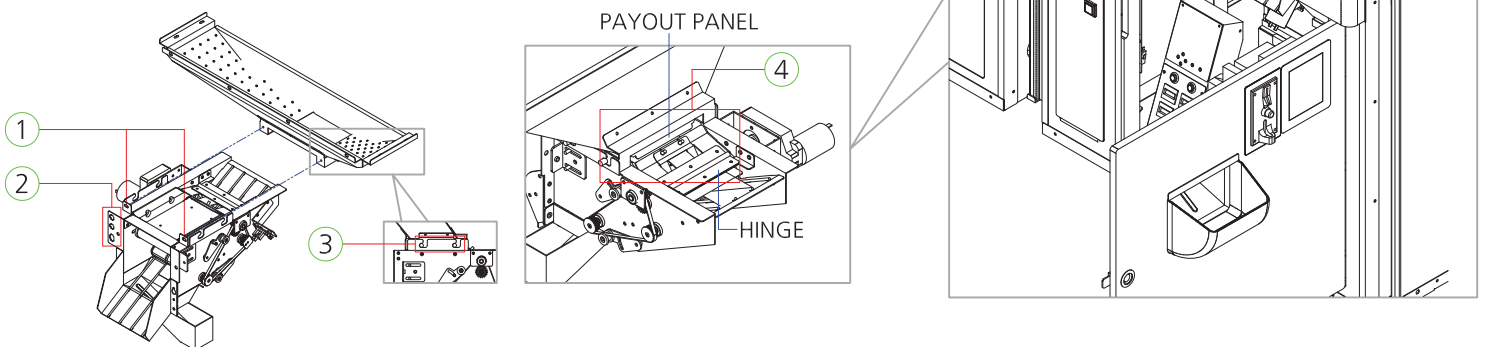

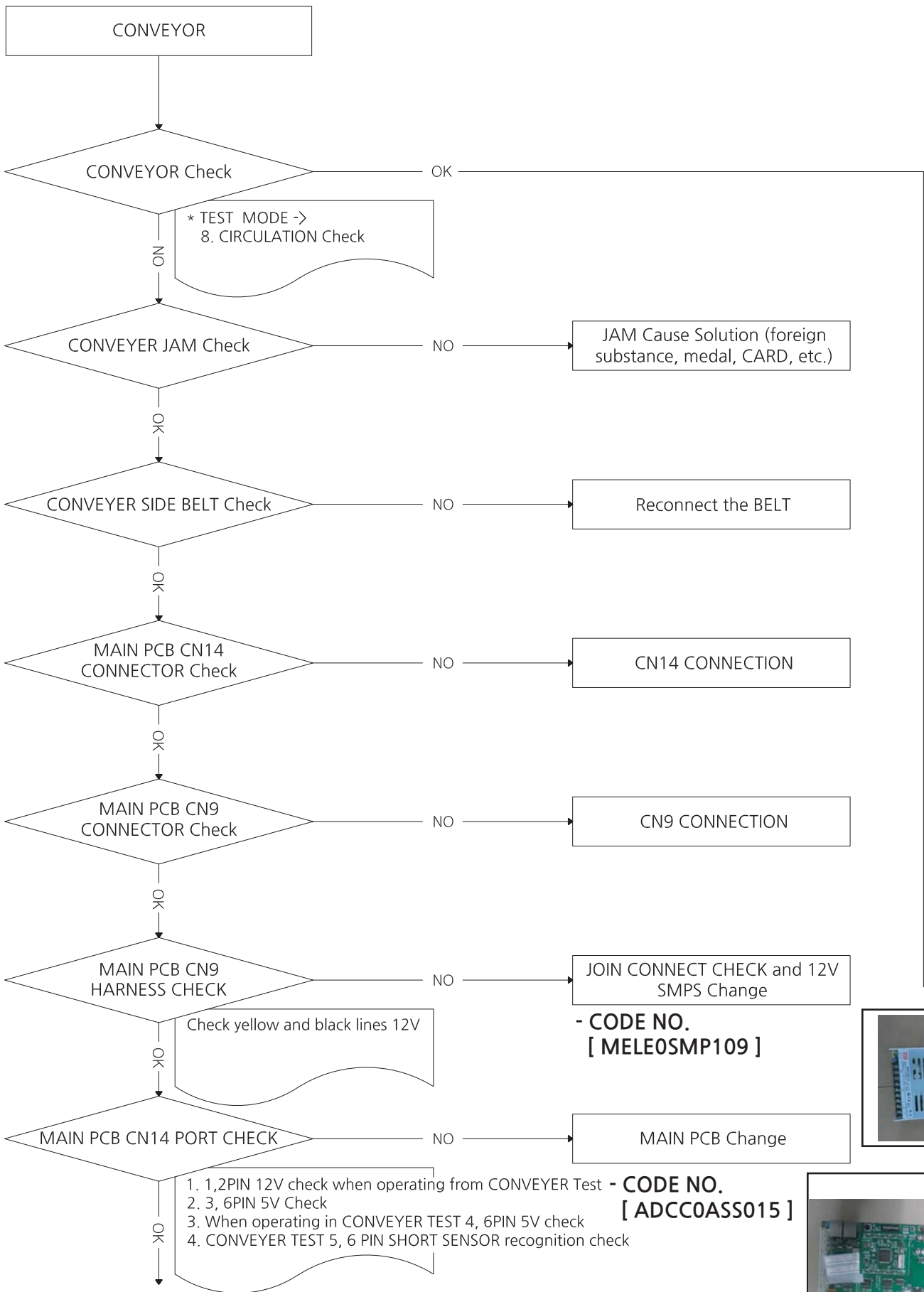

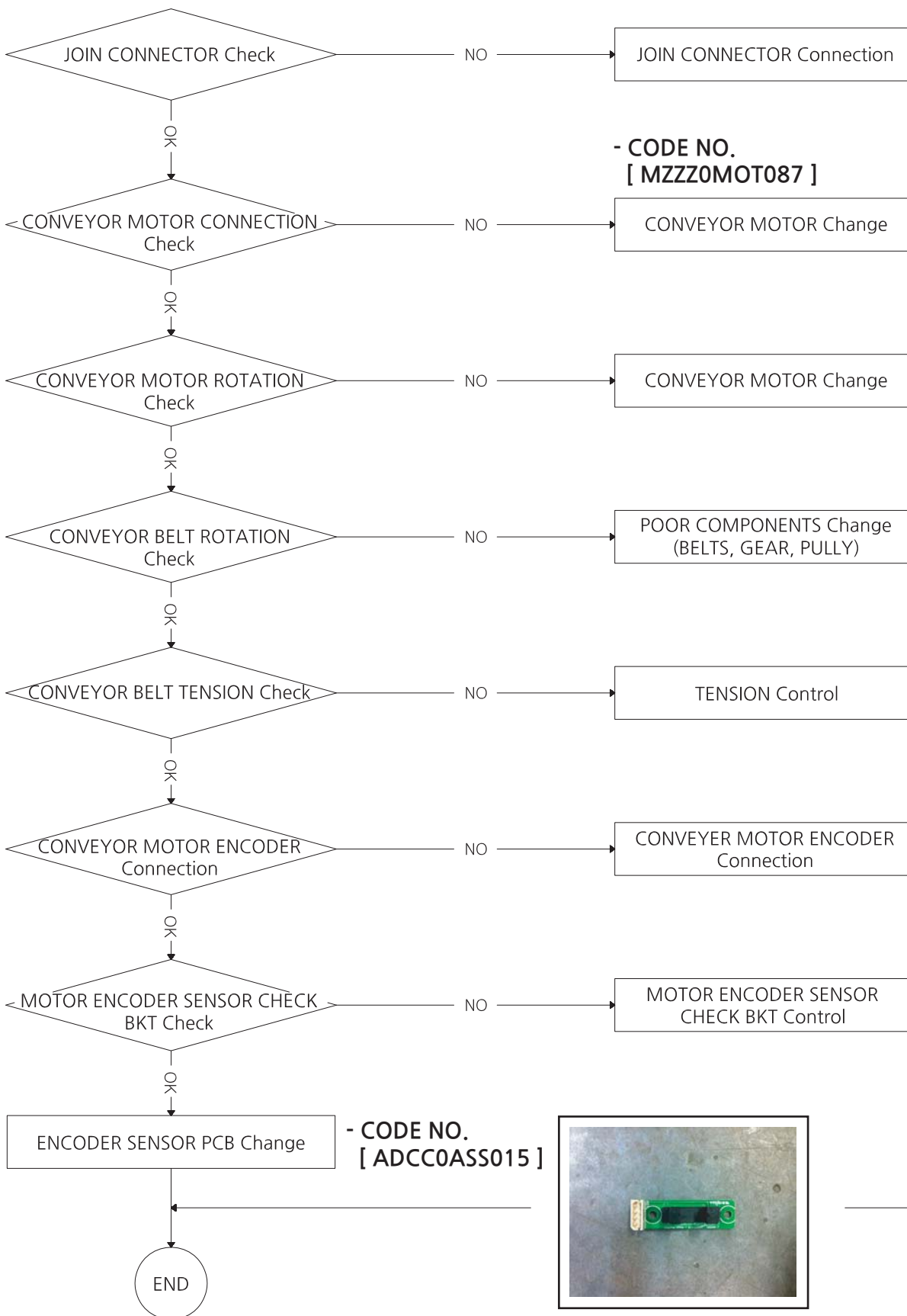

- CODE NO.
[MZZZ0MOT087]



- CODE NO.
[ADCC0ASS015]

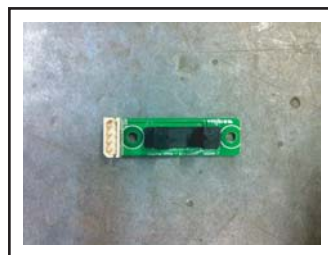

16. CARD DISPENSER ERROR [1~2P] - ERROR 11

* CAUSE - CARD JAM or EMPTY

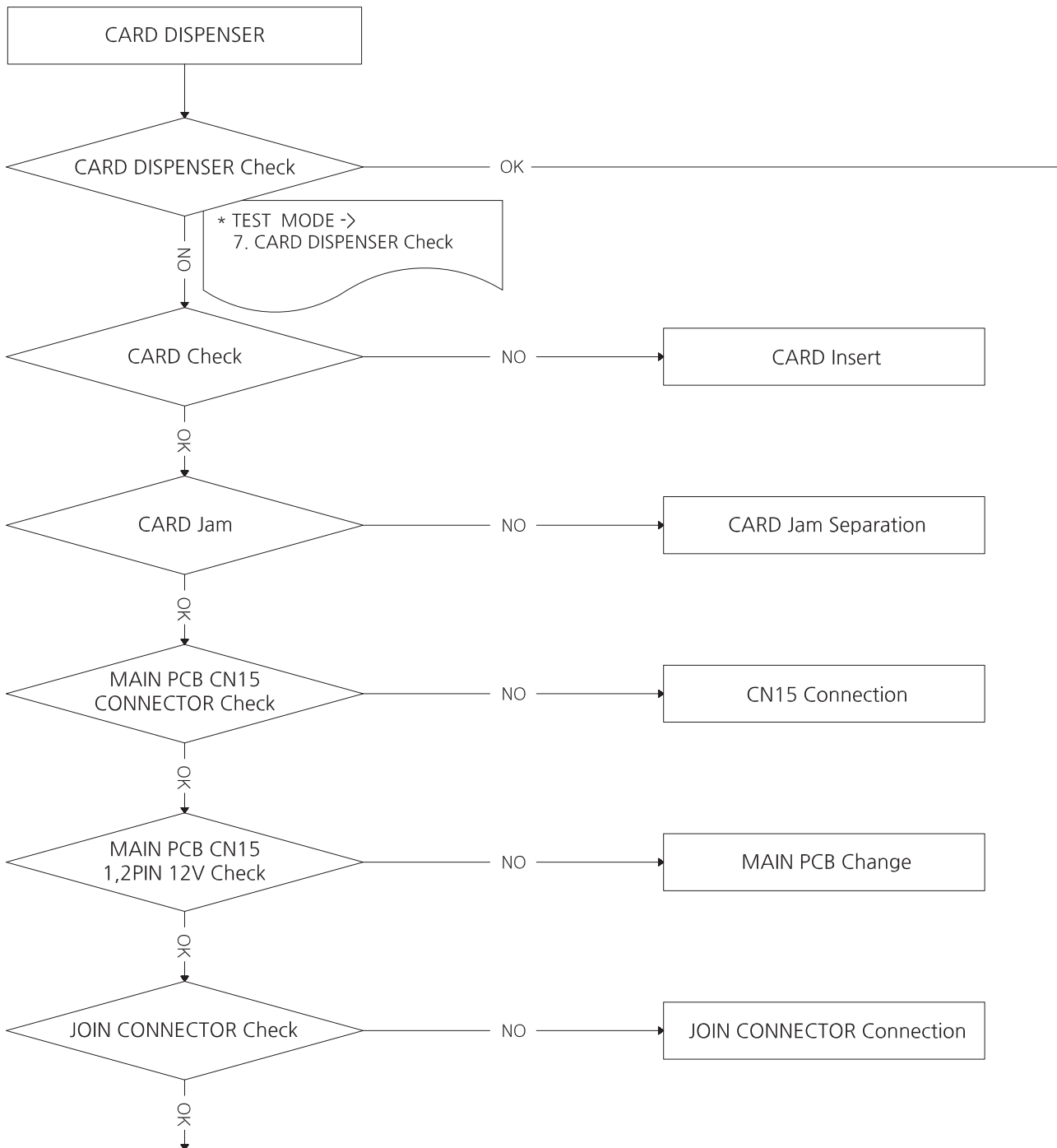
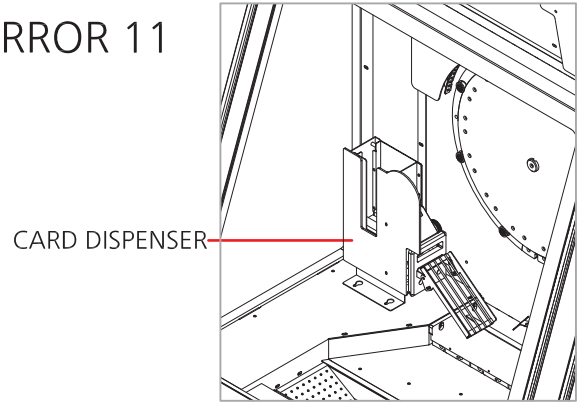

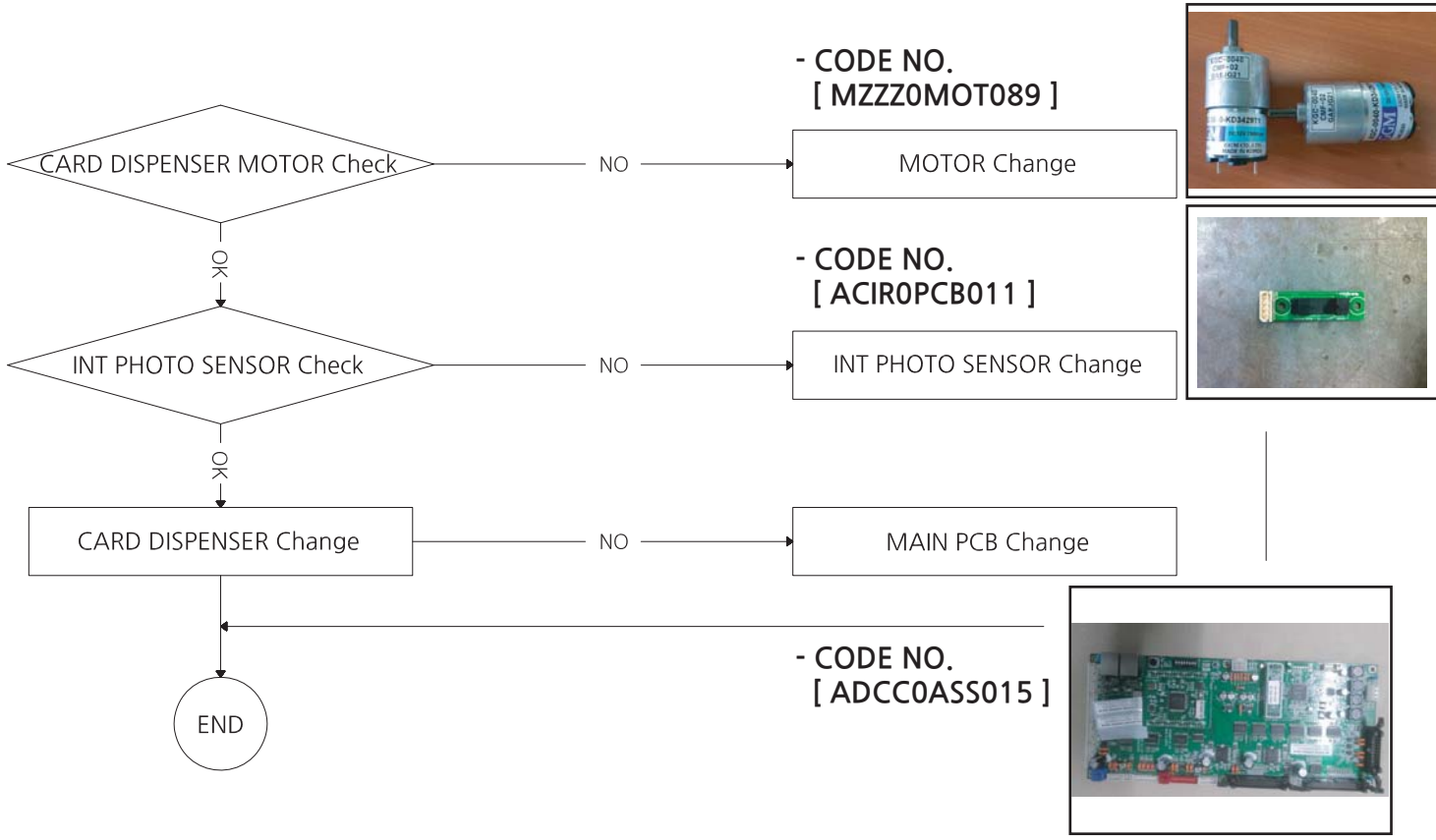

17. SOUND ERROR [1~2P]

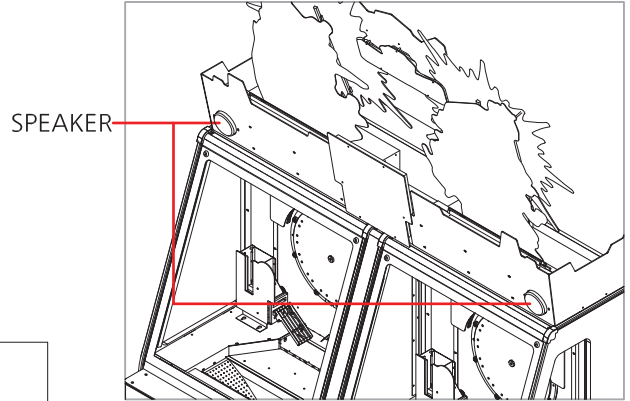
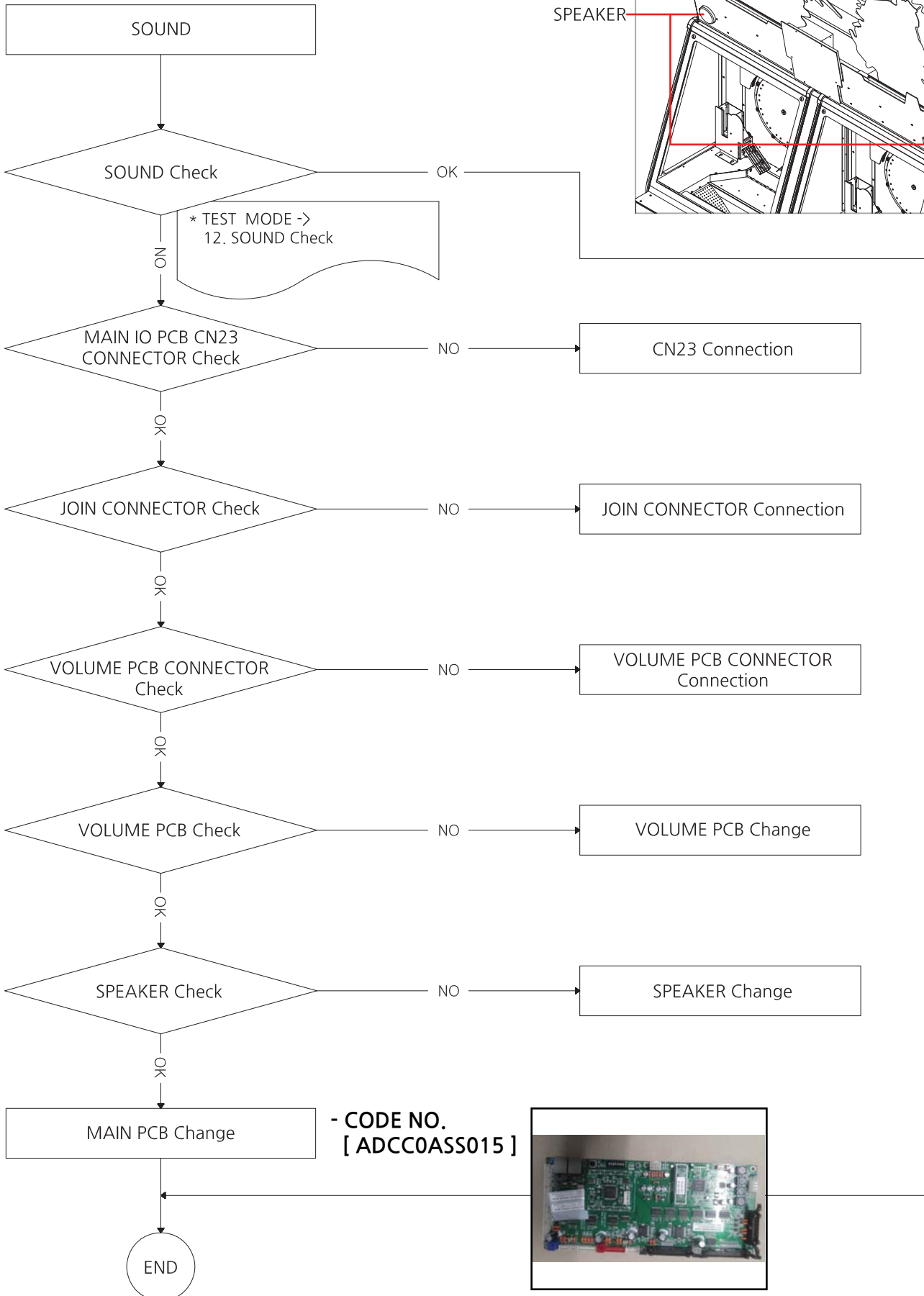

18. COIN SELECTOR ERROR [1~2P] - ERROR 02

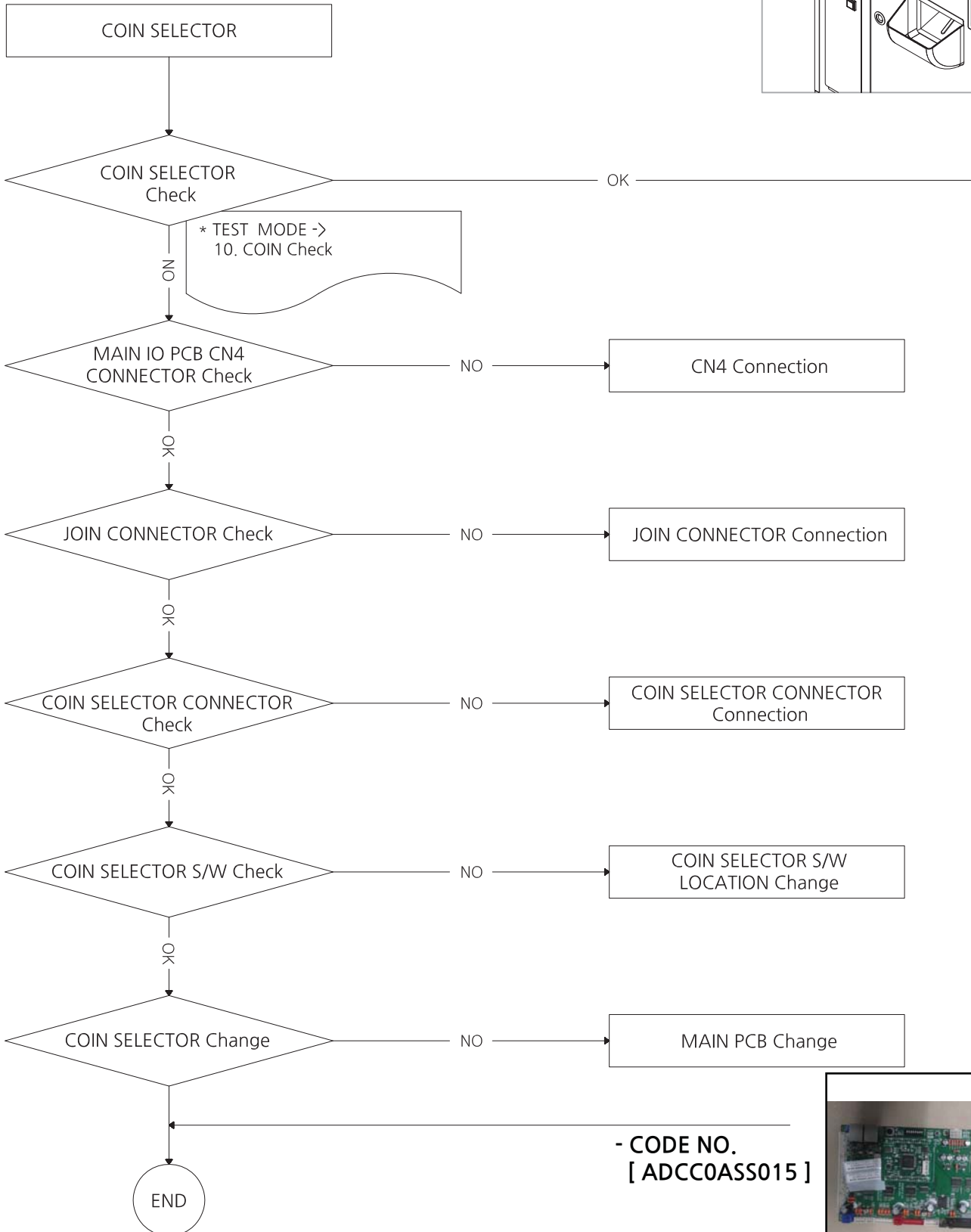
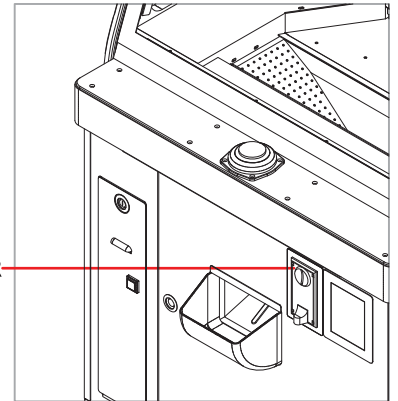

- CODE NO. [ADCC0ASS015]



19. SETUP BUTTON ERROR

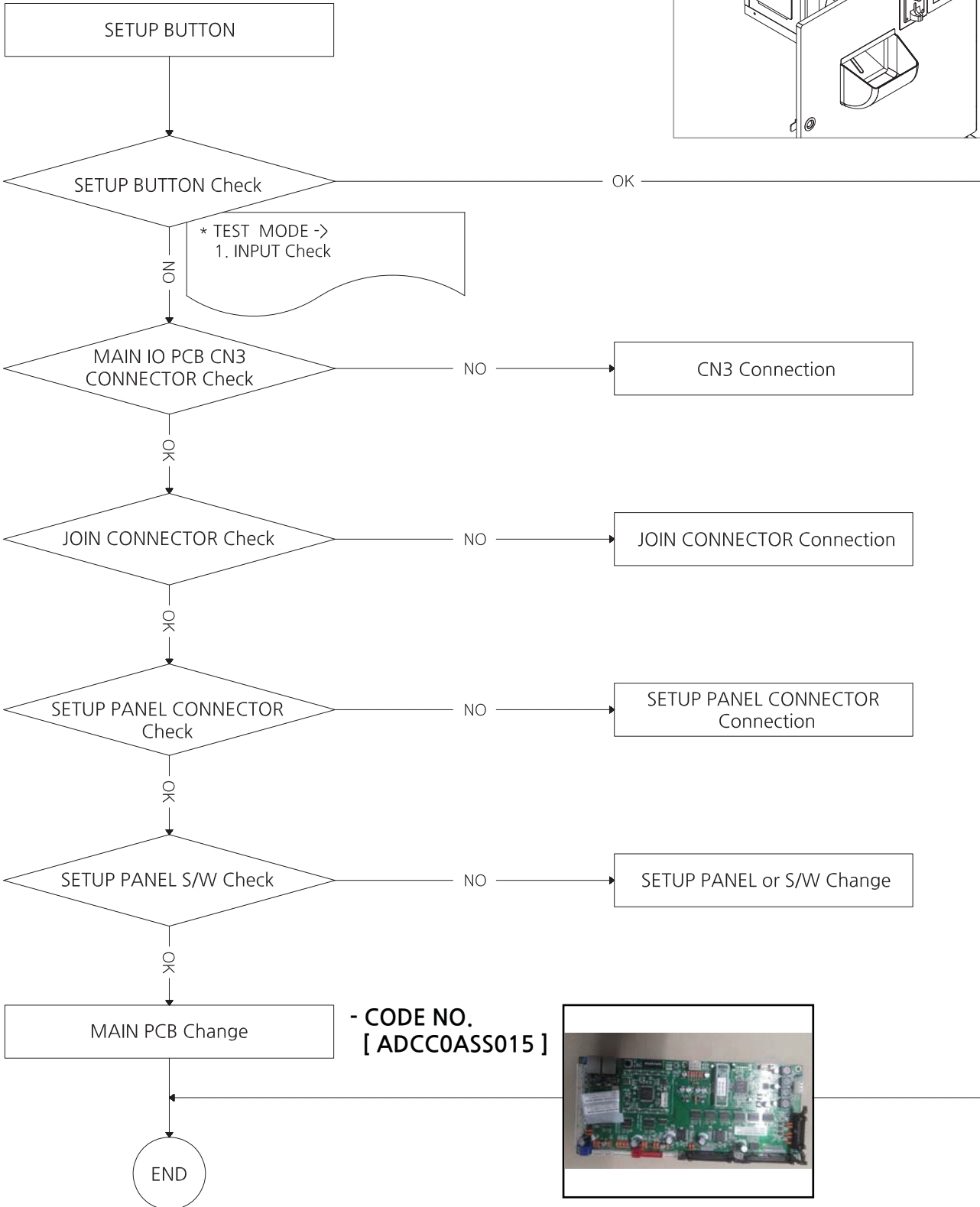
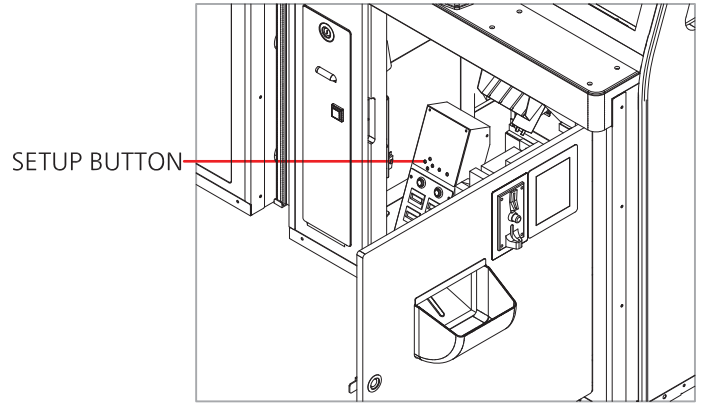

20. COUNTER ERROR [1~2P]

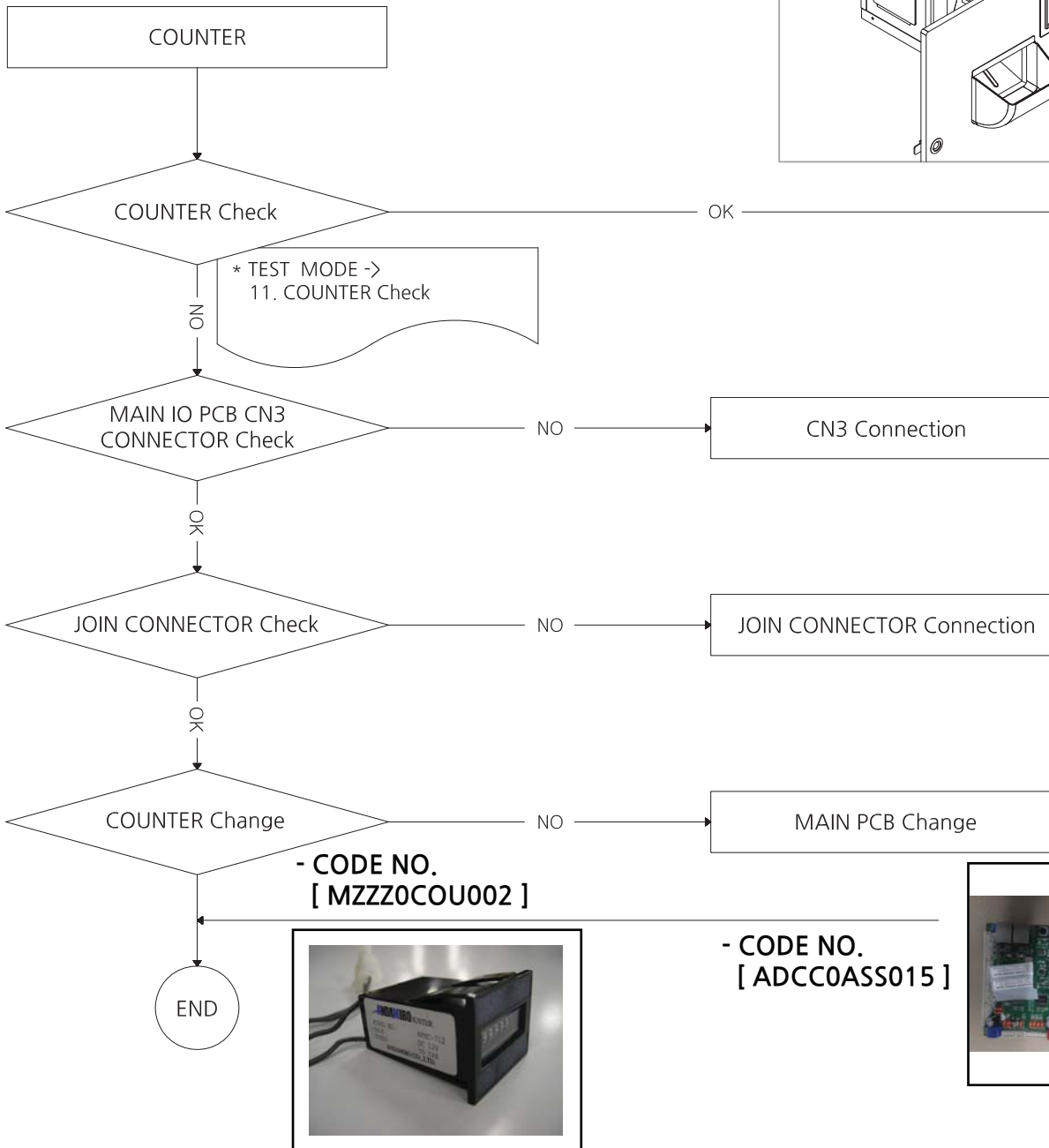
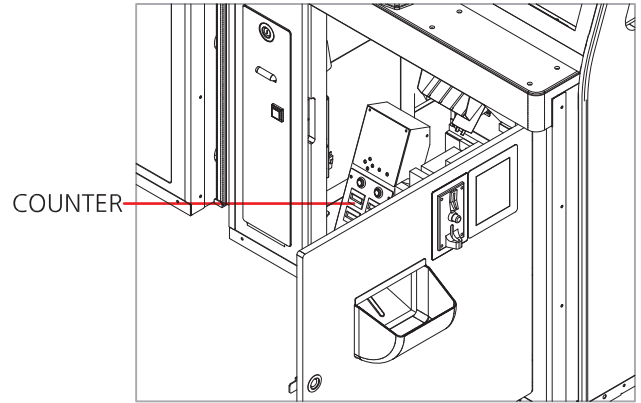

[4. PART LIST]

- BONUS FND PART

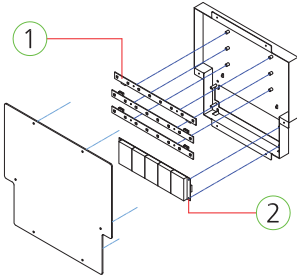

- PUSHER PANEL PART

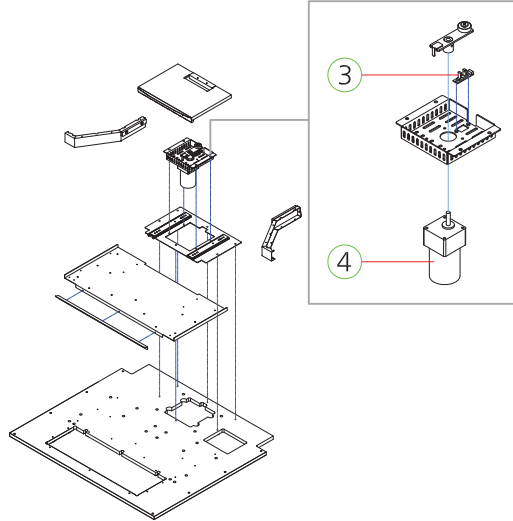

- FRONT ROLLER PART

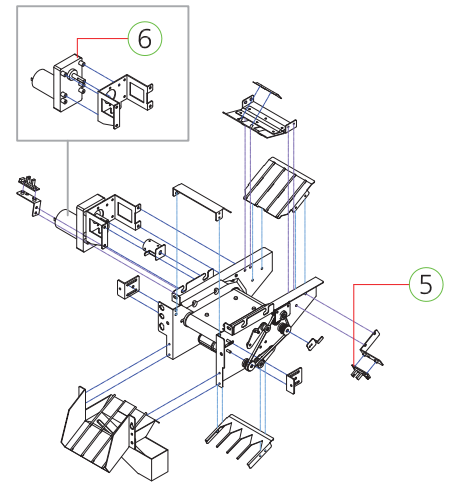

- SCORE BOARD PANEL PART

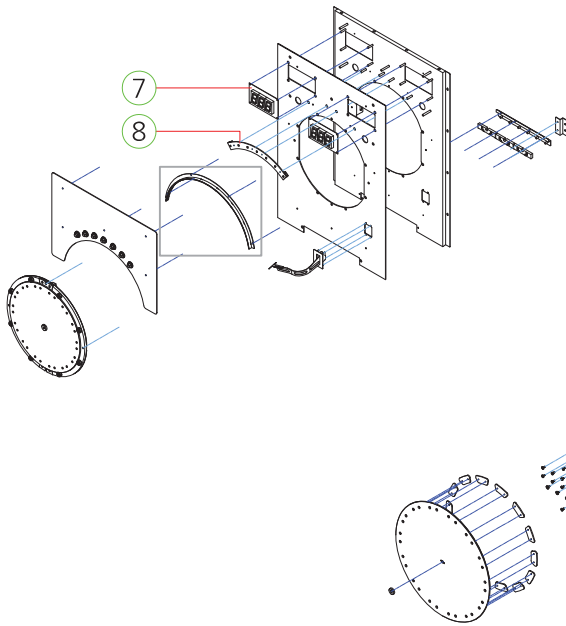

- MEDAL CIRCULATION PART

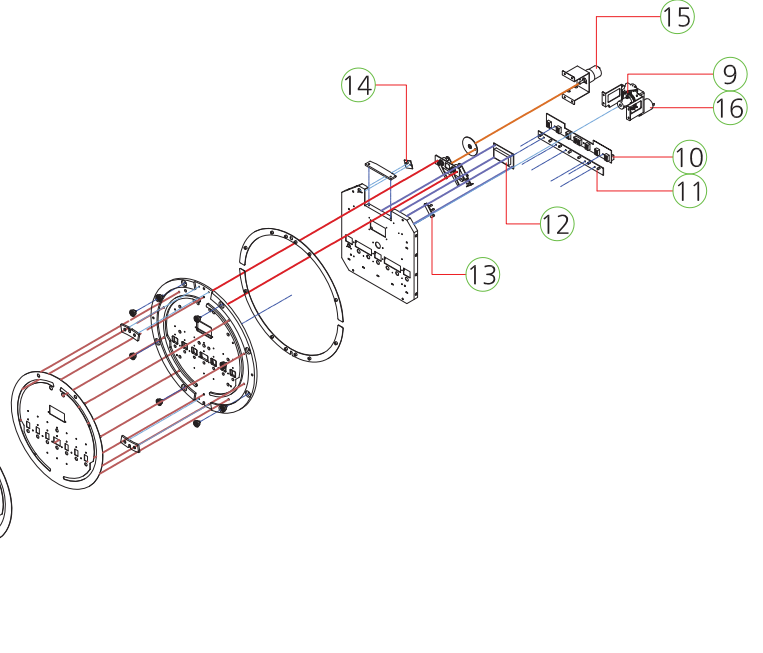

- BONUS FND PART
- SCORE BOARD PANEL PART
- MEDAL CIRCULATION PART
- PUSHER PANEL PART
- FRONT TABLE PART
- TICKET DOOR PART
- FRONT ROLLER PART
- COUNTER HOPPER PART
- SETUP PANEL PART

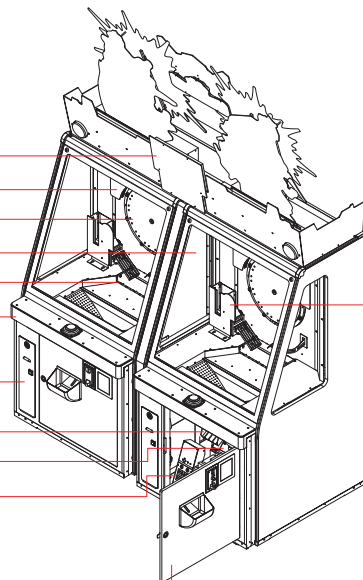

CARD DISPENSER PART

AC INPUT PART

SMPS POWER PART

MAIN BOARD PCB PART

ELEVATOR HOPPER PART

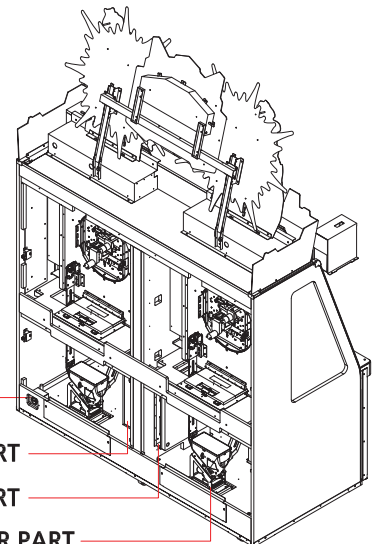

FRONT DOOR PART

- CARD DISPENSER PART

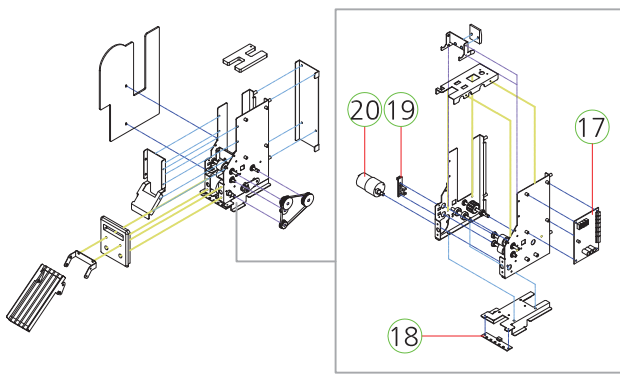

- COUNTER HOPPER PART

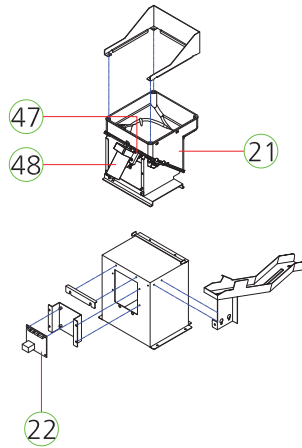

- TICKET DOOR PART

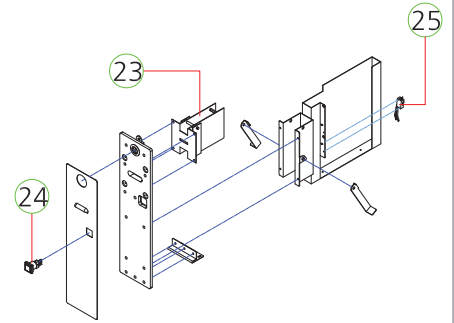

- FRONT DOOR PART

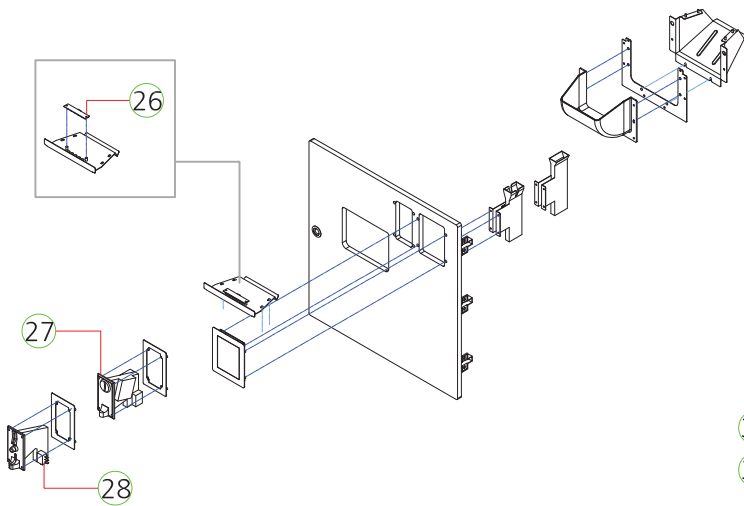

- AC INPUT PART

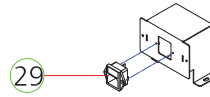

- MAIN BOARD PCB PART

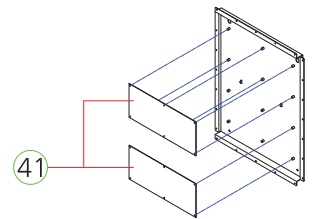

- SETUP PANEL PART

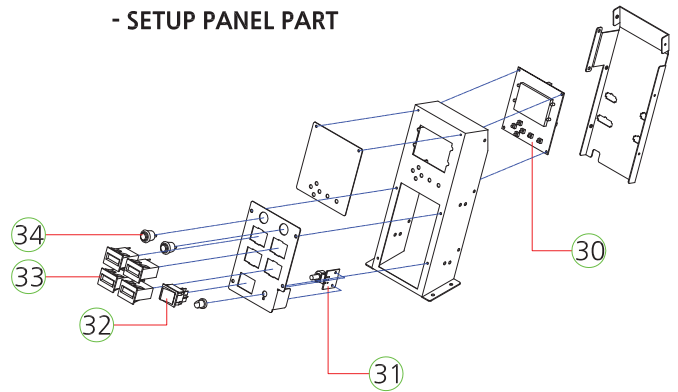

- SMPS POWER PART

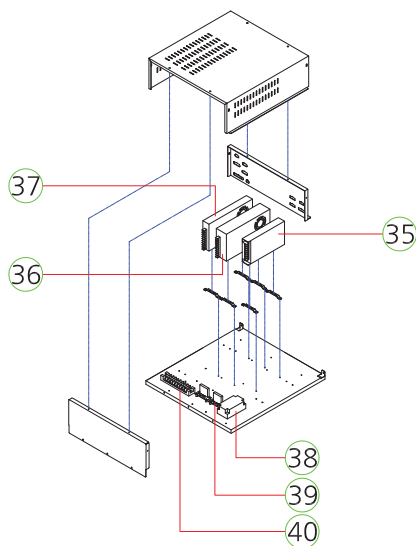

- FRONT TABLE PART

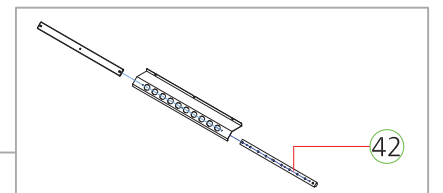
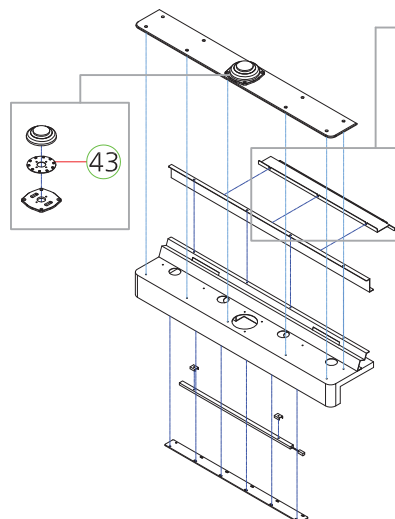



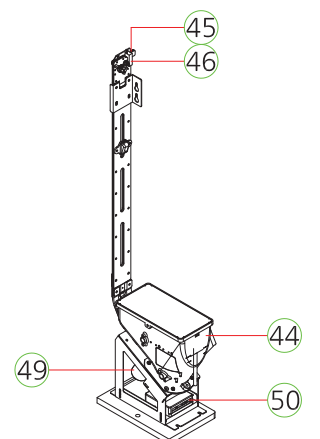



- ELEVATOR HOPPER PART



NO.	PIC	PART NAME	SPEC.	QTY	CODE NO.	WARRANTY	
						6 Month	One Year
①	○	JACKPOT LIGHTING PCB ASS'Y	-	3	ADC20PCB001		○
②	○	FND PCB ASS'Y	4870-5(STRAIGHT)	1	AFND0PCB033		○
③	○	PHOTO INT-1 ASS'Y	-	1	ACIR0PCB011		○
④	○	AC MOTOR [120V]	K6IG6NU	1	MZZZ0MOT085	○	
		AC MOTOR [220V]	K6IG6NC	1	MZZZ0MOT095	○	
⑤	○	PHOTO INT-1 PCB ASS'Y	-	2	ACIR0PCB011		○
⑥	○	MOTOR	KGV-0060 ND3657W1	1	MZZZ0MOT087	○	
⑦	○	BONUS FND PCB ASS'Y	FND-1817-3	2	ASBP0PCB003		○
⑧	○	WHEEL SPIN LED PCB ASS'Y	-	1	ADCC0PCB004		○
⑨	○	PHOTO INT1 (ANGLE) PCB ASS'Y	-	1	AZZZ0PCB103		○
⑩	○	MEDAL CIRCULATION FND PCB ASS'Y	-	1	ADCC0PCB009		○
⑪	○	MEDAL CIRCULATION CHECK-A PCB ASS'Y	-	1	ADCC0PCB006		○
⑫	○	FND PCB ASS'Y	2029-3	1	AFND0PCB028		○
⑬	○	PHOTO INT1 (ANGLE) PCB ASS'Y	-	1	AZZZ0PCB103		○
⑭	○	MEDAL CIRCULATION CHECK-B PCB ASS'Y	-	1	ADCC0PCB007		○
⑮	○	DC MOTOR	KGC-0060-ND3657U2_24V	1	MZZZ0MOT109	○	
⑯	○	DC MOTOR	KGE-0687-ND3448S1	1	MZZZ0MOT108	○	
⑰	○	CARD DISPENSOR I/O PCB ASS'Y	-	1	ASBP0PCB008		○
⑱	○	LED PCB ASS'Y	-	1	AMUM0PCB005		○
⑲	○	PHOTO INT1 (ANGLE) PCB ASS'Y	-	1	AZZZ0PCB103		○
⑳	○	MOTOR	KGC-040-3429C	1	MZZZ0MOT089	○	
㉑	○	HOPPER MACHINE	AM-CH2-1 DC	1	AZZZ0HOP035	○	
㉒	○	L6205 V2 HOPPER PCB ASS'Y	-	1	AZZZ0PCB172		○
㉓	○	TICKET DISPENSER	CLE CL-002Q_270	1	MZZZ0TID010		
㉔	○	BUTTON	AM1PB-26SH R12D	1	MMUM0BUT002		
㉕	○	MICRO SWITCH	GSM-V1631A1 [CEC]	1	MELE0MIC022		
㉖	○	LED PCB ASS'Y	-	1	AMUM0PCB005		○
㉗	○	COIN SELECTOR [INT]	TW-389	1	MZZZ0COS052		
㉘	○	COIN SELECTOR [CEC]	HS-03CS+SWITCH	1	MZZZ0COS028		
㉙	○	AC INPUT	DAC-13H	1	MELE0SWI015		
⑳	○	SETUP LCD PCB ASS'Y	-	1	AZZZ0PCB113		○
㉑	○	VOLUME PCB ASS'Y	1 VOLUME	1	AHM20PCB016		○
㉒	○	ROCKER SWITCH	R595KDF	1	MELE0SWI021		
㉓	○	COUNTER	AMMC-712(OA127CL)	4	MZZZ0COU002		
㉔	○	PUSH SWITCH	HS-412R	2	MELE0PUS006		
㉕	○	POWER SMPS	RSP-100-5	1	MELE0SMP104		○
㉖	○	POWER SMPS	SP-320-24	1	MELE0SMP089		○
㉗	○	POWER SMPS	RSP-320-12	1	MELE0SMP109		○
㉘	○	NOISE FILTER	RNS-2010	1	MELE0NOI009		
㉙	○	TERMINAL BLOCK	250V 10P UL_CE	2	MELE0TEB003		
㉚	○	SSR PCB ASS'Y	-	1	AENS0PCB001		○
㉛	○	MAIN PCB ASS'Y	WITH CPU_SOUND	1	ADCC0ASS015		○
㉜	○	BILLBOARD LED 10 PCB ASS'Y	-	1	ASBP0PCB005		○
㉝	○	BUTTON_LED PCB ASS'Y	-	1	ASHS0PCB002		○
㉞	○	ELEVATOR HOPPER BODY ASS'Y	-	1	AZZZ0ELH020	○	
㉟	○	ELEVATOR HOPPER TOP	-	1	AZZZ0ELH002	○	
㊱	○	ELEVATOR SENSOR ASS'Y	-	1	AZZZ0PCB173		○

NO.	PIC	PART NAME	SPEC.	QTY	CODE NO.	WARRANTY	
						6 Month	One Year
47	<input type="radio"/>	DC MOTOR	KGV-0105-ND4266 X2	1	MHOP0MOT001	<input type="radio"/>	
48	<input type="radio"/>	PHOTO SENSOR	LG-217L3	1	MELE0PHO007		<input type="radio"/>
49	<input type="radio"/>	ELEVATOR HOPPER MOTOR	KGV-0060-ND4266X2	1	MZZZ0ELH040	<input type="radio"/>	
50	<input type="radio"/>	ELEVATOR HOPPER PCB ASS'Y	-	1	AZZZ0PCB143		<input type="radio"/>

1	2	3	4	5	6
					
ADC20PCB001	AFND0PCB033	ACIR0PCB011	MZZZ0MOT085	ACIR0PCB011	MZZZ0MOT087





7	8	9	10	11	12
					
ASBP0PCB003	ADCC0PCB004	AZZZ0PCB103	ADCC0PCB009	ADCC0PCB006	AFND0PCB028

13	14	15	16	17	18
					
AZZZ0PCB103	ADCC0PCB007	MZZZ0MOT109	MZZZ0MOT108	ASBP0PCB008	AMUM0PCB005

19	20	21	22	23	24
					
AZZZ0PCB103	MZZZ0MOT089	AZZZ0HOP035	AZZZ0PCB172	MZZZ0TID010	MMUM0BUT002

25	26	27	28	29	30
					
MELE0MIC022	AMUM0PCB005	MZZZ0COS045	MZZZ0COS028	MELE0SWI015	AZZZ0PCB113

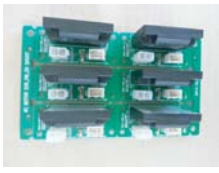
31	32	33	34	35	36
					
AHM20PCB016	MELE0SWI021	MZZZ0COU002	MELE0PUS006	MELE0SMP104	MELE0SMP089

37	38	39	40	41	42
					
MELE0SMP109	MELE0NOI009	MELE0TEB003	AENS0PCB001	ADCC0ASS015	ASBP0PCB005

43	44	45	46	48	49
					
ASHS0PCB002	AZZZ0ELH020	AZZZ0ELH002	AZZZ0PCB173	MELE0PHO007	MZZZ0ELH040

50

AZZZ0PCB143