

SERVICE MANUAL







Ver 1.4_INT



[IMPORTANT]

- ▶ Please read the manual carefully and keep it in mind before using this machine
- ▶ Put this manual within touch of your reference in anytime.

ISSUE DATE:May. 24, 2022

PRODUCT INFO	PART INFO	SUPPORT INFO	NEW PRODUCT INFO
			

※ QR(SUPPROT) - Leaflets, manuals, solution(error code, trouble shooting document, watch&solve)

PRECAUTIONS FOR USE

The following safety precautions are given throughout this manual. They must be strictly followed to protect those who install, use or maintain this product as well as to protect players, visitors and property.

For safety reasons.

- The following suggestions should be adhered to:



WARNING

Disregarding could result in serious injury.



CAUTION

Disregarding could result in injury or product damage.

- The following graphic suggestions describe the types of precautions to be followed.



Indicates a care should be taken.



Forbidden.



Indicates a matter which must be performed.

- **Precautions to be followed:**

Certain procedures require a qualified in-shop maintenance person or industry specialist.

For such instructions, a qualified person must take care of the jobs.

- Otherwise an electric shock, machine trouble or a serious accident may result.
- Replacing the machine parts, inspecting and maintaining the machines and troubleshooting must be assigned only to a qualified in-shop maintenance person or industry specialist. This booklet gives instructions that hazardous jobs in particular must be handled by an industry specialist. Qualified in-shop maintenance person and industry specialist are defined as follows.

Qualified in-shop maintenance person

- A service staff shall have experience in operations of game machines. The staff shall be responsible for assembly, installation, inspection and maintenance of the machine.

Industry specialist

- An industry specialist must be engaged in designing, manufacturing, inspecting and servicing amusement machines. He or she must have an education in electrical, electronic and mechanical engineering and routinely maintain and repair amusement machines.

PRECAUTIONS FOR USE

WARNING

Be sure to consult an industry specialist when setting up, moving or transporting this product.

- This product should not be set up, moved or transported by any one other than an industry specialist.
- When installing this product, set the 4 leg levelers evenly on the floor and make sure that the product is installed stably in a horizontal position. Unstable installation may result in injury or accident.
- When installing this product, do not apply undue force on movable parts. Otherwise, injury and accident may result, or the product may be damaged.

The machine for indoor usage only does not install outside.



Do not set the game machine up near emergency exits.



Protect the game machine from:

- Rain or moisture.
- Direct sunlight.
- Direct heat from air-conditioning and heating equipment, etc..
- Hazardous flammable substances.
- Otherwise an accident or malfunction may result.



Do not place containers holding chemicals or water on or near the game machine.



Do not place objects near the ventilating holes.



Do not bend the power cord by force or place heavy objects on it.



Never plug or unplug the power cord with wet hands.



Never unplug the game machine by pulling the power cord.



CAUTION

Be sure to use indoor wiring within the specified voltage requirements. For extension cord, use the specified rating or more.

Be sure to use the attached power cord.

Never plug more than one cord at a time into the electrical receptacle.



Do not lay the power cord where people walk through.



Be sure to ground this product.



Do not exert excessive force when moving the machine.



For proper ventilation, keep the game machine 100mm(4") away from the walls.

Do not alter the system related dipswitch settings.

PRECAUTIONS FOR USE

WARNING

If there is any abnormality such as smoke, bad smell or abnormal noise being emitted from the machine, immediately turn OFF the main power switch and unplug the power cord from the receptacle to stop operating it. 

- Using the machine in abnormal conditions could result in fire or accidents.

In case of abnormality

1. Turn OFF the main power switch.
2. Unplug the power cord from the receptacle.
3. Contact your nearest dealer.

Do not leave the power cord plugged in improperly or covered with dust. 

- Doing so could result the power cord periodically.

CAUTION

Do not use this product anywhere other than industrial areas. 

- Using in a residential area or an area next to a residential area could affect signal reception of radios, television sets, telephones and etc..
- Do not give shock the surface of glass products.

- Please do not play this game if
 - When you do drinking;
 - When your physical condition is not normal;
 - When you are in pregnancy;
 - When you have on a pulse controller;
 - When you have recently experienced a cramp or fainting away while watching TV.
- Avoid excessive force/shock while playing/moving the game.
- While do games, pay attention to surrounding.

Do not plug or unplug the power cord with wet hands. 

In handling the power cord, follow the instructions below. 

- | | |
|---|--|
| • Do not damage the power cord. | • Do not modify the power cord. |
| • Do not bend the power cord excessively. | • Do not twist the power cord. |
| • Do not heat the power cord. | • Do not pull the power cord. |
| • Do not bind the power cord. | • Do not stand on the power cord. |
| • Do not sandwich the power cord. | • Do not drive a nail into the power cord. |

If the power cord or power plug becomes damaged, stop using the machine immediately and ask your nearest dealer to replace the parts.

*** Electromagnetic wave may cause unexpected noise from speaker.**

PRECAUTIONS FOR USE

⚠ WARNING

Be sure to turn OFF the main power switch and unplug the power cord from the receptacle before inspecting or cleaning the machine.



When replacing parts, be sure to use parts of the correct specifications. Never use parts other than the specified ones.



Opening inside the machine shall be done by machine specialist only as high electric current is being sent inside. For game machine with monitor, a care should be taken while opening its back door. If not, a damage to the inside parts or the monitor may occur.



If the sub power switch of the service panel is turned OFF without turning OFF the main power switch of the power supply unit, some parts in the units remain live. When opening the back door, be sure to turn OFF the main power switch and unplug the power cord from the receptacle.



Strictly refrain from disassembly and repair of parts which are not indicated in this manual, as well as settings and remodeling.



To clean the game machine, wipe it with a soft cloth dampened in a neutral detergent.

- Using thinner or other organic solvent or alcohol may decompose the material.
- Electrical shock or equipment failure could be caused by water entering the inside of the machine.

⚠ CAUTION

Components in the game are sensitive to vibrations and impact. Care should be used when moving and transporting the game machine.



Be sure not to let the machine tip over.

Before moving the machine, be sure to turn OFF the main power switch, unplug the power cord from the receptacle and remove the power cord from the machine.



Before moving take the machine, off the levelers and move it on the casters.

Avoid excessive force while moving the machine.

.....

PRECAUTIONS IN HANDLING

- When setting up, inspecting, maintaining, moving or transporting this product, follow the procedures and instructions set forth in this manual and perform such work safely.
- Do not set up, handle, inspect, maintain, move or transport this product under conditions equivalent to the condition of "WARNING" or "CAUTION" specified in this manual.
- If a new owner is to have this product as a result of transfer, and etc., be sure to give this manual to the new owner.

PRÉCAUTION D'EMPLOI

Les consignes de sécurité suivantes sont données dans ce manuel. Elles doivent être strictement suivies pour protéger ceux qui les installent. Utiliser ou entretenir ce produit pour la sécurité des utilisateurs, des visiteurs et des biens.

Pour des raisons de sécurité.

- **Les suggestions suivantes doivent être respectées:**

ATTENTION

Le non-respect peut entraîner des blessures graves.

PRUDENCE

Le non-respect peut entraîner des blessures ou des dommages au produit.

- **Les suggestions graphiques suivantes décrivent les types de précautions à prendre.**



Indique qu'attention est requise.



Interdit.



Indique que quelque chose doit être effectuée.

- **Les précautions à prendre :**

Certaines procédures exigent une personne de maintenance qualifiée en atelier ou un spécialiste de l'industrie. Pour ces instructions, une personne qualifiée doit prendre soin des travaux.

- Sinon, un choc électrique, un dysfonctionnement de la machine, ou un accident grave peut en résulter.
- Remplacement des pièces de machines, l'inspection et la maintenance des machines, et le dépannage doit être attribué qu'à une personne de maintenance qualifiée en atelier ou spécialiste de l'industrie. Cette brochure donne des instructions que les emplois dangereux, en particulier, doivent être traités par un spécialiste de l'industrie. La personne de maintenance qualifiée en atelier et le spécialiste de l'industrie sont définis comme suit.

La personne de maintenance qualifiée en atelier

- Un personnel de service doit avoir de l'expérience dans les opérations de machines de jeux. Le personnel est responsable pour l'assemblage, l'installation, l'inspection et l'entretien de la machine.

Le spécialiste de l'industrie

- Un spécialiste de l'industrie doit être engagé dans la conception, la fabrication, l'inspection et l'entretien des appareils d'amusement.
Il ou elle doit avoir une formation en génie électrique, électronique et mécanique, et de maintenir régulièrement et de réparer les appareils d'amusement.

PRÉCAUTION D'EMPLOI

ATTENTION

Si il y a une anomalie comme fumée, mauvaise odeur ou bruit anormal émis par la machine,  couper immédiatement l'interrupteur principal et débranchez le câble d'alimentation de la prise pour arrêter son fonctionnement.

- L'utilisation de l'appareil dans des conditions anormales peut provoquer un incendie ou un accident.

En cas d'anomalie

1. Mettez l'interrupteur principal sur ARRÊT.
2. Débranchez le câble d'alimentation de la prise.
3. Contactez votre revendeur le plus proche.

Ne pas brancher le câble d'alimentation incorrectement ou le laisser être recouvert de poussière. 

Cela pourrait nuire le câble d'alimentation.

PRUDENCE

Ne pas utiliser ce produit ailleurs que dans les zones industrielles. 

- L'utiliser dans une zone résidentielle ou d'une zone à côté d'un quartier résidentiel pourrait nuire à la réception des radios, téléviseurs, téléphones, etc.
- Ne donnez pas de choc à la surface d'un produit en verre.

- S'il vous plaît ne pas jouer à ce jeu.
 - Quand vous buvez;
 - Lorsque votre condition physique n'est pas normale;
 - Lorsque vous êtes dans une période de grossesse;
 - Lorsque vous avez un contrôleur d'impulsion;
 - Lorsque vous avez récemment subi une crampe ou évanouissement en regardant la télévision.
- Évitez une force excessive / un choc pendant la lecture / de déplacer le jeu.
- Quand vous jouez les jeux, faites attention aux alentours.

Ne pas brancher ou débrancher le câble d'alimentation avec les mains mouillées. 

Dans la manipulation du câble d'alimentation, suivez les instructions ci-dessous. 

- | | |
|--|---|
| • Ne pas endommager le câble d'alimentation. | • Ne pas modifier le câble d'alimentation. |
| • Ne pas plier le câble d'alimentation de manière excessive. | • Ne tordez pas le câble d'alimentation. |
| • Ne pas chauffer le câble d'alimentation. | • Ne tirez pas sur le câble d'alimentation. |
| • Ne pas lier le câble d'alimentation. | • Ne montez pas sur le câble d'alimentation. |
| • Ne pas prendre en sandwich le câble d'alimentation. | • Ne pas mettre un clou dans le câble d'alimentation. |

Si la fiche du câble d'alimentation ou est endommagé, cessez immédiatement d'utiliser la machine et demandez à votre revendeur le plus proche de remplacer les pièces.

PRÉCAUTION D'EMPLOI

⚠ ATTENTION

Assurez-vous de consulter un spécialiste de l'industrie lors de la mise en place, du déplacement ou le transport de ce produit.

- Ce produit ne doit pas être mis en place, déplacé ou transporté par une quelconque autre qu'un spécialiste de l'industrie.
- Lors de l'installation de ce produit, installez 4 niveleurs de pieds uniformément sur le sol et assurez-vous que le produit est installé de façon stable dans une position horizontale. Une installation instable peut entraîner des blessures ou un accident.
- Lors de l'installation de ce produit, ne pas appliquer une force excessive sur les pièces mobiles. Sinon, des blessures et des accidents peuvent y résulter, ou le produit peut être endommagé.

La machine pour une utilisation en intérieur uniquement, ne pas installer à l'extérieur.



N'installez pas la machine de jeu près des issues de secours.



Protéger la machine de jeu de:



- L'humidité ou la pluie.
- La lumière directe du soleil.
- La chaleur directe de la climatisation et du chauffage, etc...
- Des substances inflammables dangereuses.
- Sinon, un accident ou un dysfonctionnement.

Ne pas placer les récipients contenant des produits chimiques ou de l'eau sur ou près de la machine de jeu.



Ne placez pas d'objets à proximité des orifices de ventilation.



Ne pas plier le cordon d'alimentation par la force ou de placer des objets lourds au-dessus.



Ne jamais brancher ou débrancher le cordon d'alimentation avec les mains mouillées.



Ne jamais débrancher la machine de jeu en tirant le câble d'alimentation.



⚠ PRUDENCE

Veillez à utiliser le câblage intérieur selon les exigences de tension spécifiées. Pour une rallonge, utilisez la notation spécifiée ou plus.

Veillez à utiliser le cordon d'alimentation fourni.

Ne jamais brancher plus d'un cordon à la fois dans la prise électrique.



Ne pas poser le cordon d'alimentation où les gens marchent à travers.



Soyez sûr de mettre à la terre ce produit.



Ne pas exercer une force excessive lors du déplacement de la machine.



Pour une ventilation correcte, garder la machine de jeu 100mm (4 ") loin des murs.

Ne pas modifier les réglages des commutateurs DIP liées au système.

PRÉCAUTION D'EMPLOI

ATTENTION

Veillez à éteindre l'interrupteur d'alimentation principale et débranchez le cordon d'alimentation de la prise avant d'inspecter ou de nettoyer la machine. 

Lors du remplacement des pièces, veillez à utiliser une partie des spécifications correctes. Ne jamais utiliser de pièces autres que celles spécifiées. 

L'ouverture à l'intérieur de la machine doit être effectuée par le spécialiste de la machine seulement, comme le courant électrique élevé est transmis à l'intérieur. Pour la machine de jeu avec le moniteur, un soin doit être pris lors de l'ouverture de sa porte arrière. Si non, une détérioration des pièces à l'intérieur ou à l'écran peut se produire. 

Si l'interrupteur secondaire du panneau de service est éteint sans éteindre le commutateur d'alimentation principale de l'unité d'alimentation, certaines parties dans les unités restent sous tension. Lors de l'ouverture de la porte arrière, veillez à éteindre l'interrupteur d'alimentation principale et débranchez le cordon d'alimentation de la prise. 

Il est strictement conseillé de s'abstenir de démonter et de réparer des pièces qui ne sont pas indiqués dans ce manuel, ainsi que les paramètres et le remodelage. 

Pour nettoyer la machine de jeu, l'essuyer avec un chiffon doux imbibé avec un détergent neutre.

- L'utilisation plus mince d'un autre solvant organique ou de l'alcool peut décomposer le matériel.
- Un choc électrique ou une défaillance de l'équipement pourraient être causés par la pénétration de l'eau à l'intérieur de la machine.

PRUDENCE

Les composants de la machine de jeu sont sensibles aux vibrations et aux chocs. Il faut faire attention lors du déplacement et le transport de la machine de jeu. 

Veillez à ne pas laisser la machine se renverser.

Avant de déplacer la machine, veillez à éteindre l'interrupteur d'alimentation principale, débranchez le cordon d'alimentation de la prise et débranchez le cordon d'alimentation de la machine. 

Avant de déplacer la machine, la mettre hors des niveleurs et le déplacer sur les roulettes.

Éviter une force excessive lors du déplacement de la machine.

.....

PRÉCAUTIONS LORS DU MANIEMENT

- Lors de la mise en place, l'inspection, l'entretien, déplacement ou le transport de ce produit, suivez les procédures et les instructions énoncées dans ce manuel et effectuer ce travail en toute sécurité.
- Ne pas mettre en place, manipuler, inspecter, entretenir, déplacer ou transporter ce produit dans des conditions équivalentes à l'état de "ATTENTION" ou "PRUDENCE" spécifiée dans ce manuel.
- Si un nouveau propriétaire obtient ce produit à la suite d'un transfert, etc., soyez sûr de donner ce manuel au nouveau propriétaire.

CONTENTS

1. SPECIFICATION AND DIMENSION	P04
1-1. DIMENSION	P04
1-2. SPECIFICATION	P04
1-3. NAME OF PARTS	P05
1-4. STICKER LOCATION	P06
1-5. COMPONENTS	P07
2. INSTALLATION	P08
2-1. INSTALLATION SPACE	P08
2-2. HOW TO INSTALL	P09
3. SETUP SETTINGS	P12
3-1. MACHINE SETUP	P12
3-2. SETUP MODE	P13
3-3. CLEAR MODE	P17
3-4. TEST MODE	P19
3-5. ERROR CODE	P22
4. TROUBLESHOOTING	P26
4-1. BIGWIN MOTOR ERROR [Er.31 or Er.32]	P26
4-2. BIGWIN MOTOR ERROR [Er.33 or Er.34]	P28
4-3. SLOPE SENSOR ERROR [Er.51 or Er.52]	P30
4-4. SLOPE SENSOR ERROR [Er.53]	P32
4-5. STOPPER MOTOR ERROR [Er.41 or Er.42] - NO SIGNAL FROM ENCODER	P33
# IN CASE STOPPER MOTOR DOES NOT WORK	P33
# IN CASE STOPPER MOTOR NOT WORK	P34
5. EXPLODED VIEW	P35
5-1. MAIN CABINET PART	P35
5-2. UPPER CABINET PART	P36
(1) BACKGROUND PART	P37
(2) SIDE DECO-L, R PART	P38
(3) DOOR-L, R PART	P38
5-3. FRONT CABINET PART	P39
(1) MAIN BOARD BOX PART	P40

(2) FRONT SIDE PCB PART	P40
(3) CONTROL PANEL PART	P41
(4) FRONT CABINET BOTTOM FLEX LED PART	P41
(5) FRONT DECO-L, R PART	P42
(6) SIDE LED SENSOR-L, R PART	P43
(7) SIDE GO LED-L, R PART	P44
(8) SIDE LED NO SENSOR-L, R PART	P45
(9) SPEAKER COVER PART-L, R PART	P46
(10) RAIL COVER FRONT-L, R PART	P47
(11) RAIL COVER REAR-L, R PART	P47
(12) CAR MOVING PART	P48
(13) CAR STOPPER PART	P49
(14) FRONT CENTER COVER PART	P50
(15) TICKET DOOR PART	P51
(16) COIN BOX PART	P51
(17) BUTTON PART	P52
(18) FRONT DOOR-L, R PART	P52
(19) FRONT CABINET PROTECT ACRYL PART	P53
(20) FRONT DAMPER PART	P54
5-4. REAR CABINET PART	P55
(1) SMPS POWER PART	P56
(2) AC INPUT PART	P57
(3) UPPER CABINET FOREST BOTTOM LED PART	P57
(4) BIGWIN MOVEMENT-L, R PART	P58
(5) SIDE LED-L, R SENSOR LAST PART	P59
(6) SIDE LED-L, R NO SENSOR LAST PART	P59
(7) BIGWIN COVER PART-L PART	P60
(8) BIGWIN COVER PART-R PART	P60
(9) RAIL COVER REAR PART	P61
(10) RAIL COVER FRONT L, R PART	P61
(11) REAR CENTER COVER PART	P62
(12) FND PART	P63

6. WARRANTY ITEM & PART PICTUREP64
*** HOW TO CONNECT THE CARD SWIPEP69**
7. BLOCK DIAGRAMP70

1. SPECIFICATION AND DIMENSION

1-1. DIMENSION

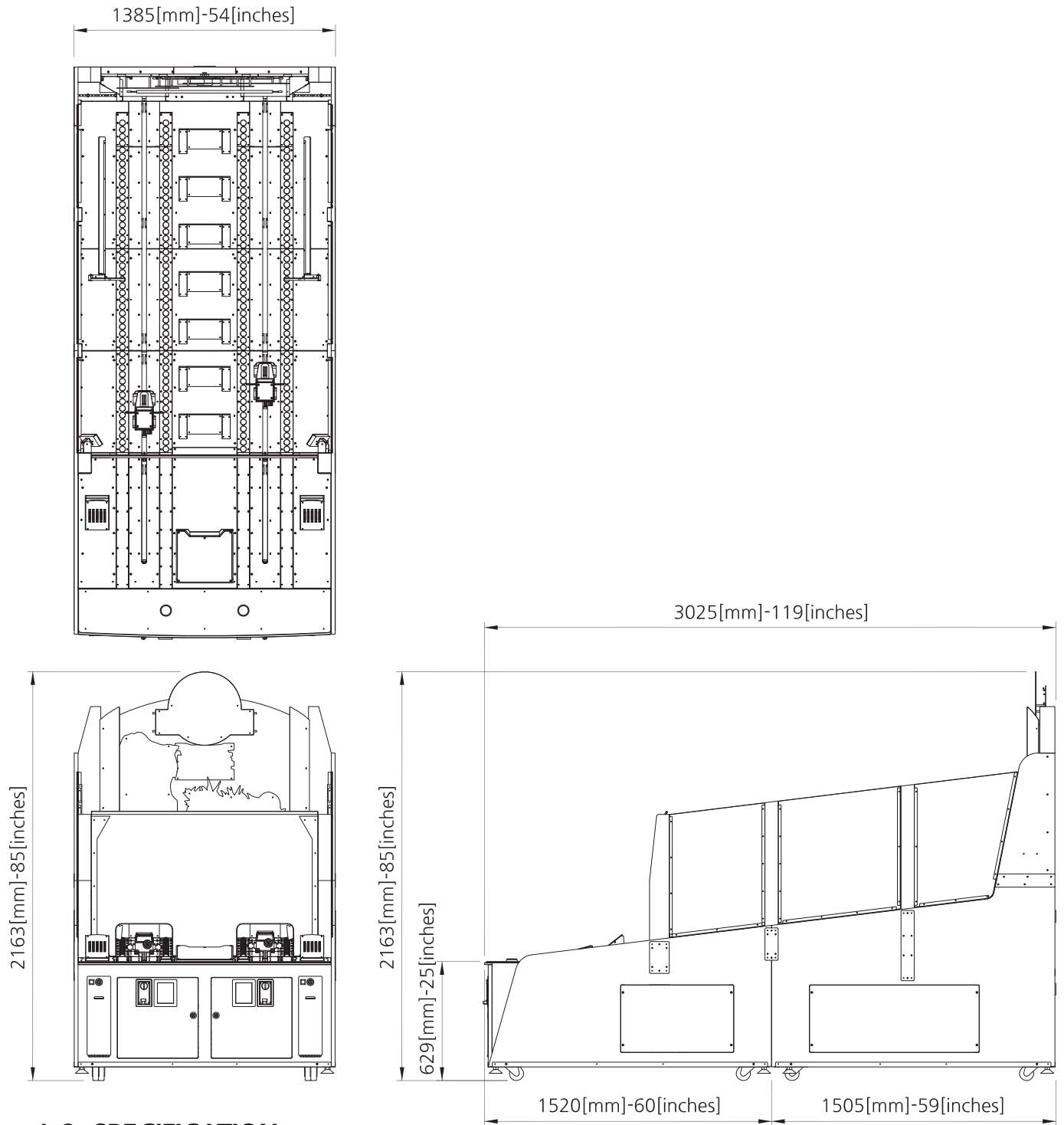

1-2. SPECIFICATION

DIMENSION (W x D x H)	1385 x 3025 x 2163 (mm)
PACKING DIMENSION (W x D x H)	F:1660 x 1540 x 1030 / R:1660 x 1540 x 1220 / U:1540 x 640 x 1330(mm)
WEIGHT (kg)	F:235kg (260) / R:315kg (350) / U:80kg (105)
VOLTAGE	AC 120V
FREQUENCY RANGE	60Hz
CONSUMPTION	400 W

* The 120V voltage specification is for the Americas only, and the 230V (50/60Hz) voltage specifications are for other countries.

1-3. NAME OF PARTS

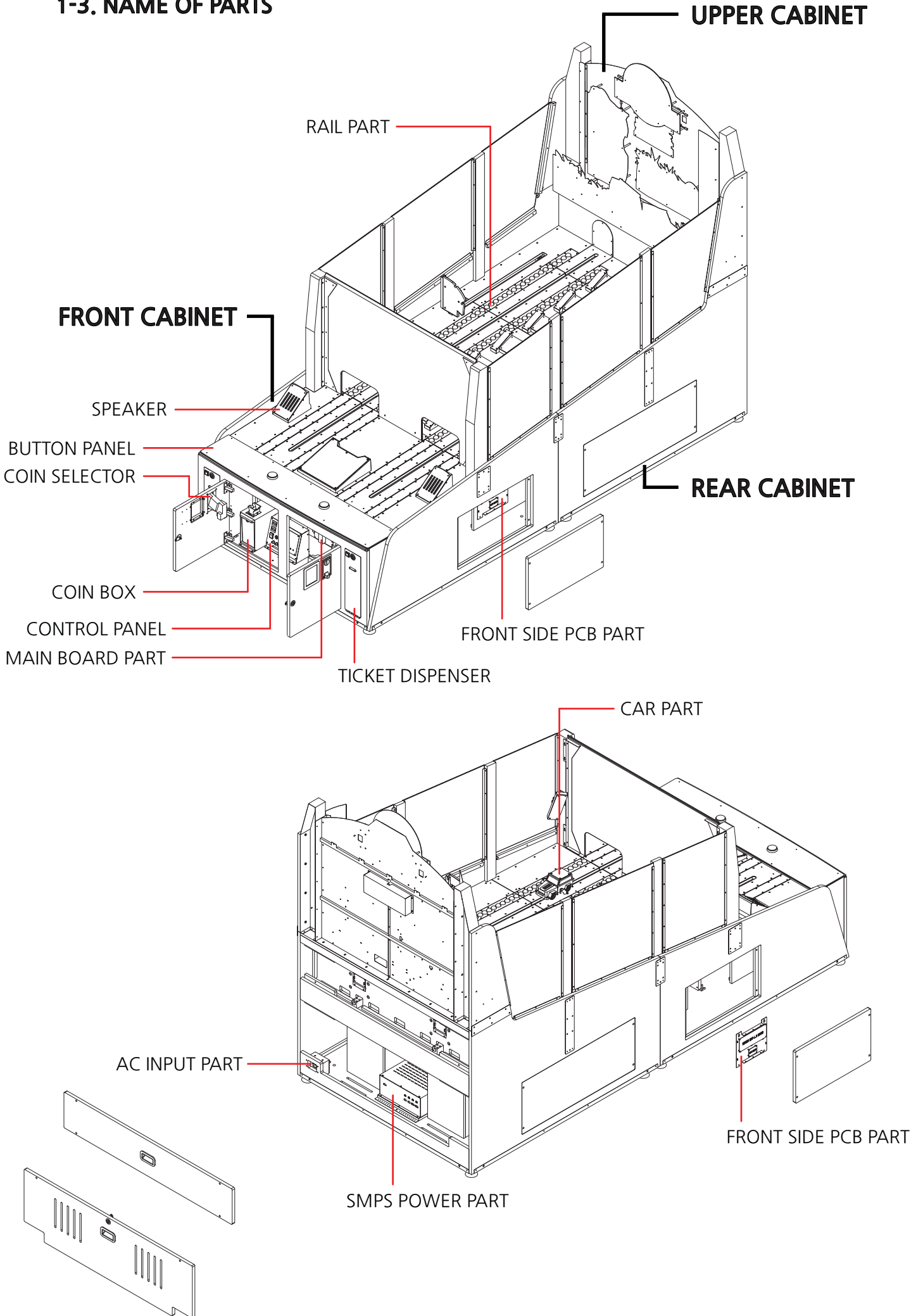

1-4. STICKER LOCATION

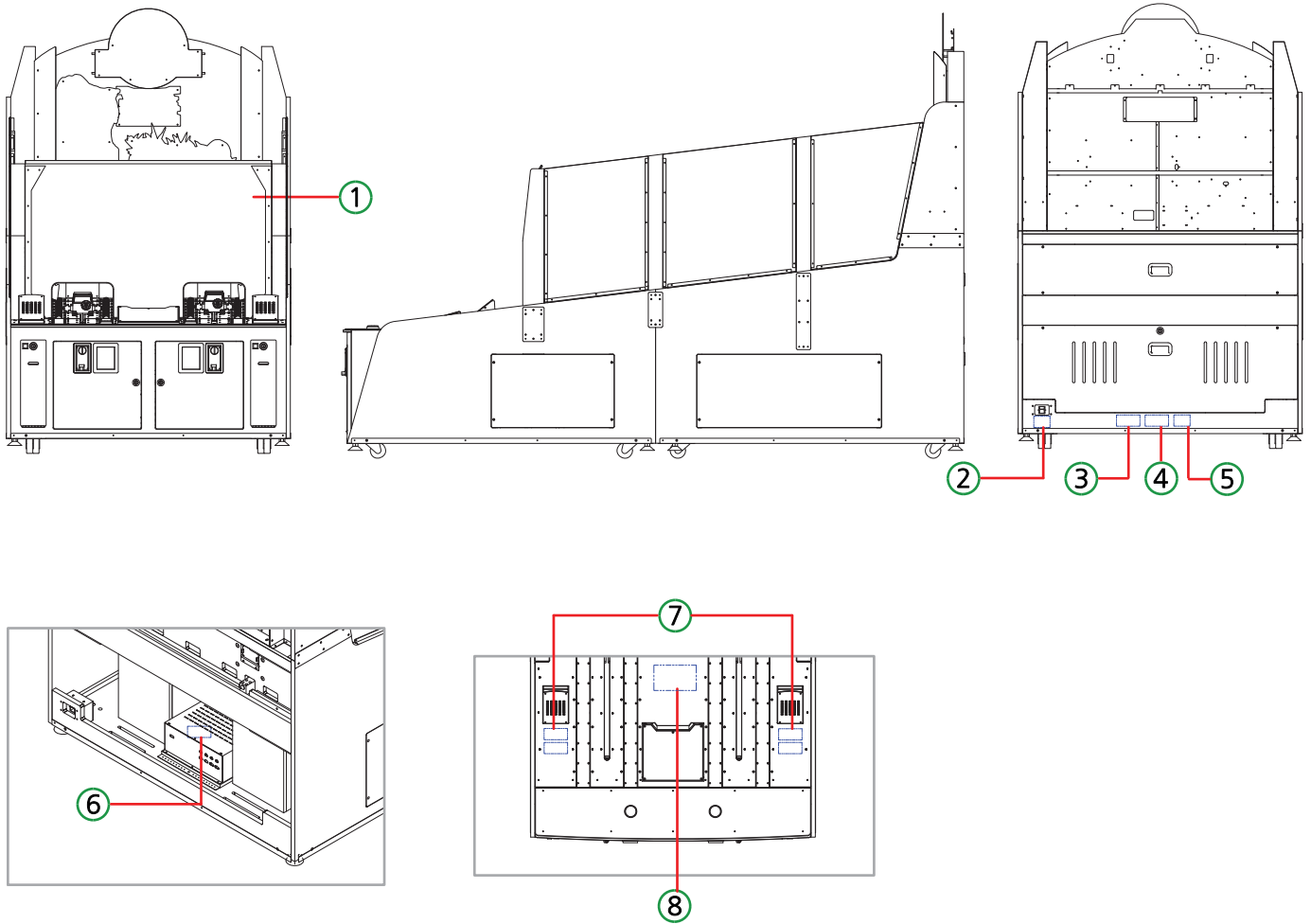

1



Do not push or hit this. It would be damaged.
Ne pas la pousser ou frapper. Elle serait endommagée.

2

CAUTION/PRUDENCE

"For continuous protection against risk of fire, replace only with the same type 10A-250V fuse"

"Pour une protection continue contre les risques d'incendie, remplacer un fusible avec seulement le même type 10A-250V"

3

Certification Label

4

WARNING
 ROCKING, SHAKING, OR TIPPING MAY CAUSE INJURY OR DEATH!
 This unit must be fastened securely to the wall, floor or adjacent object in compliance with the installation instructions.

ATTENTION
 AGITER, SECOUER OU BASCULER PEUT CAUSER DES BLESSURES OU ENTRAÎNER LA MORT!
 Cette unité doit être fixée au mur, au plancher ou à un objet à proximité conformément aux instructions d'installation.

5



6

WARNING/ATTENTION

Except service personnel, please never open the product as there is a risk of electric shock.

Il y a un risque d'électrocution, n'ouvrez pas le produit excepté le responsable, s'il vous plaît.

7

CAUTION/PRUDENCE

Putting your hands or heads near car area while car operation may injure.







Le fait de placer vos mains ou votre tête à proximité de la zone du véhicule pendant le fonctionnement peut vous blesser gravement.

8

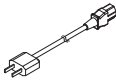
NOTICE

Keep Off! Climbing, walking or sitting on the game cabinet can cause severe injuries

1-5. COMPONENTS

NO.	PART NAME	SPEC.		QTY	ADDITIONAL DESCRIPTION
1	AC POWER CORD	-		1	
2	COIN SELECTOR COVER BKT	-		2	
3	MANUAL	-		1	
4	ERROR CODE	-		1	
5	KEY	7001		2	
6	WRENCH	2.5, 3, 4, 5 mm		1 EACH	
7	SCREW	TH_BLACK M4x8L		22	FOR FND COVER ACRYL, CAR POINT LIGHT ASS'Y
8	SCREW	TH_BLACK M4x12L		36	FOR WINDOW ACRYL- A,B,C
9	SCREW	TH_WRENCH_NI M4x16L		2	FOR WINDOW ACRYL- A,B,C
10	SCREW	TH_BLACK M4x16L		2	FOR WINDOW LOWER BKT-L,R
11	SCREW	TH_BLACK M4x20L		4	FOR DECO FIX BKT-L,R
12	SCREW	SEMS M6x16L		7	FOR UPPER CABINET
13	SCREW	LH_BLACK M6x20L		6	FOR SUPPORT BKT L,R
14	SCREW	LH_BLACK M6x35L		36	FOR DECO FIX BKT-L,R
15	SCREW	SPARE		-	

2. INSTALLATION

2-1. INSTALLATION SPACE

- Need to have installation place.
Maintenance zone & Play zone should have at least 3500mm x 5000mm each.

***IMPORTANT**

- Once you set up the machine with required game-play area, when installing this product, set the 4 leg levelers evenly on the floor and make sure that the product is installed stably in a horizontal position.

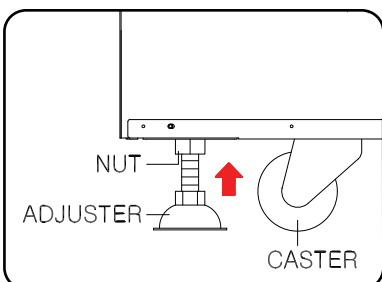
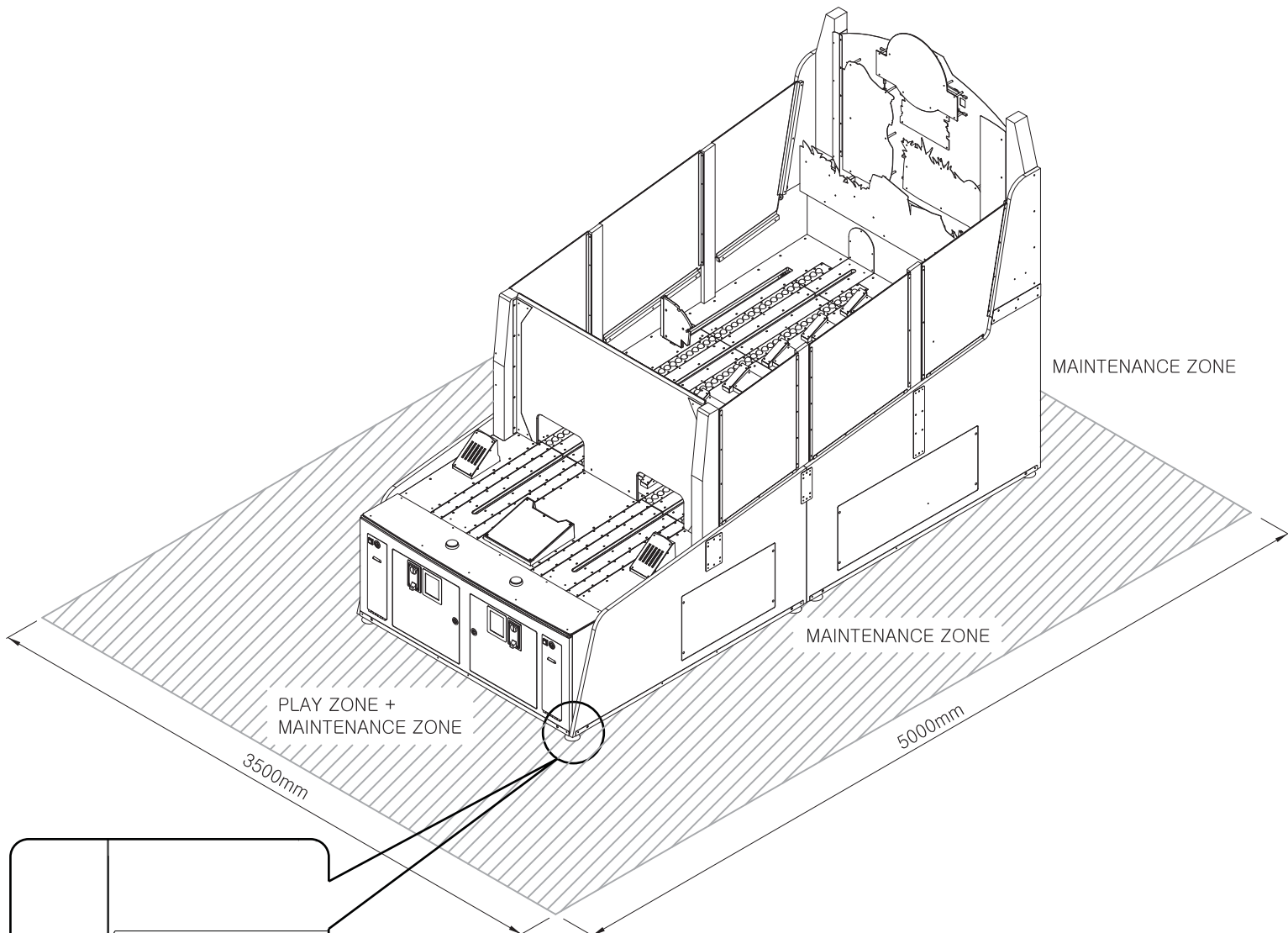

2-2. HOW TO INSTALL

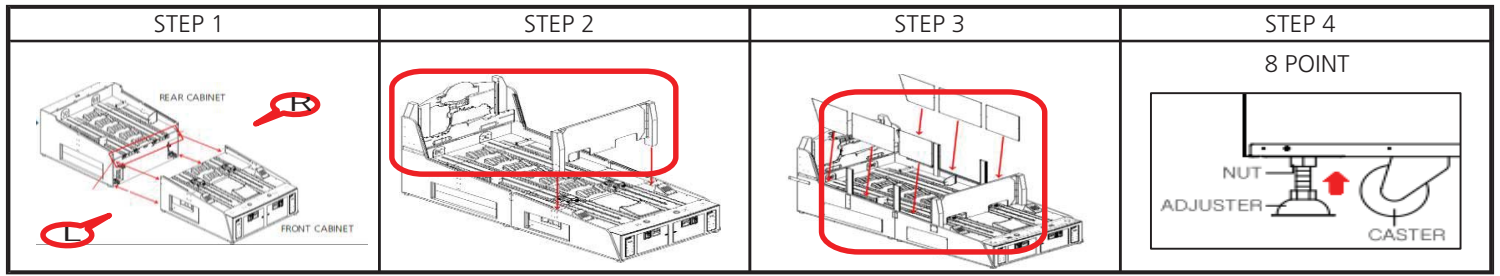

no	PROCESS	ITEM	Q'ty	BOLT	SPEC	Q'ty	no	PROCESS	ITEM	Q'ty	BOLT	SPEC	Q'ty
1	REMOVE	CAR HOLD BKT-A, B	4	LH NI TH NI	6*30 4*12	4 4	6	Arrange	wiring arrangement	4			
	ASSEMBLE	BOLT		LH NI TH NI	6*30 4*12	4 4	7	CONNECT	WIRING -SIDE L	6	caution (8pin - 2 pcs)		
2	REMOVE	BIGWIN GUIDE BKT	2	LH NI	6*30	4	7-1	CONNECT	WIRING - SIDE L	5	caution (8pin - 1 pcs)		
	ASSEMBLE	BOLT		LH NI	6*30	4	8	CONNECT	WIRING - SIDE R	4			
3	REMOVE	SIDE COVER PLATE	4	LH_BL	6*35	16	8-1	CONNECT	WIRING - SIDE R	5			
	MOVE	FRONT-REAR SPACE:10Cm(4inch)						9	MOVE	FRONT CABINET			
5	CONNECT	WIRING	4				10	ASSEMBLE	FRONT ,REAR CABINET				
※ NOTE							※CAUTION: WIRE KINKS, ASSEMBLE+-, NO GAP						

- ▼1,▼2 : Must be used when moving the product (CAR HOLD BKT-A, B, BIGWIN GUIDE BKT)
- When connecting the wires, check the color and shape of the connector of the opposite wire. ▼7, ▼7-1, ▼8, ▼8-1

3. OPTION : There are options from 7 to 8-1. Refer to page 11-1

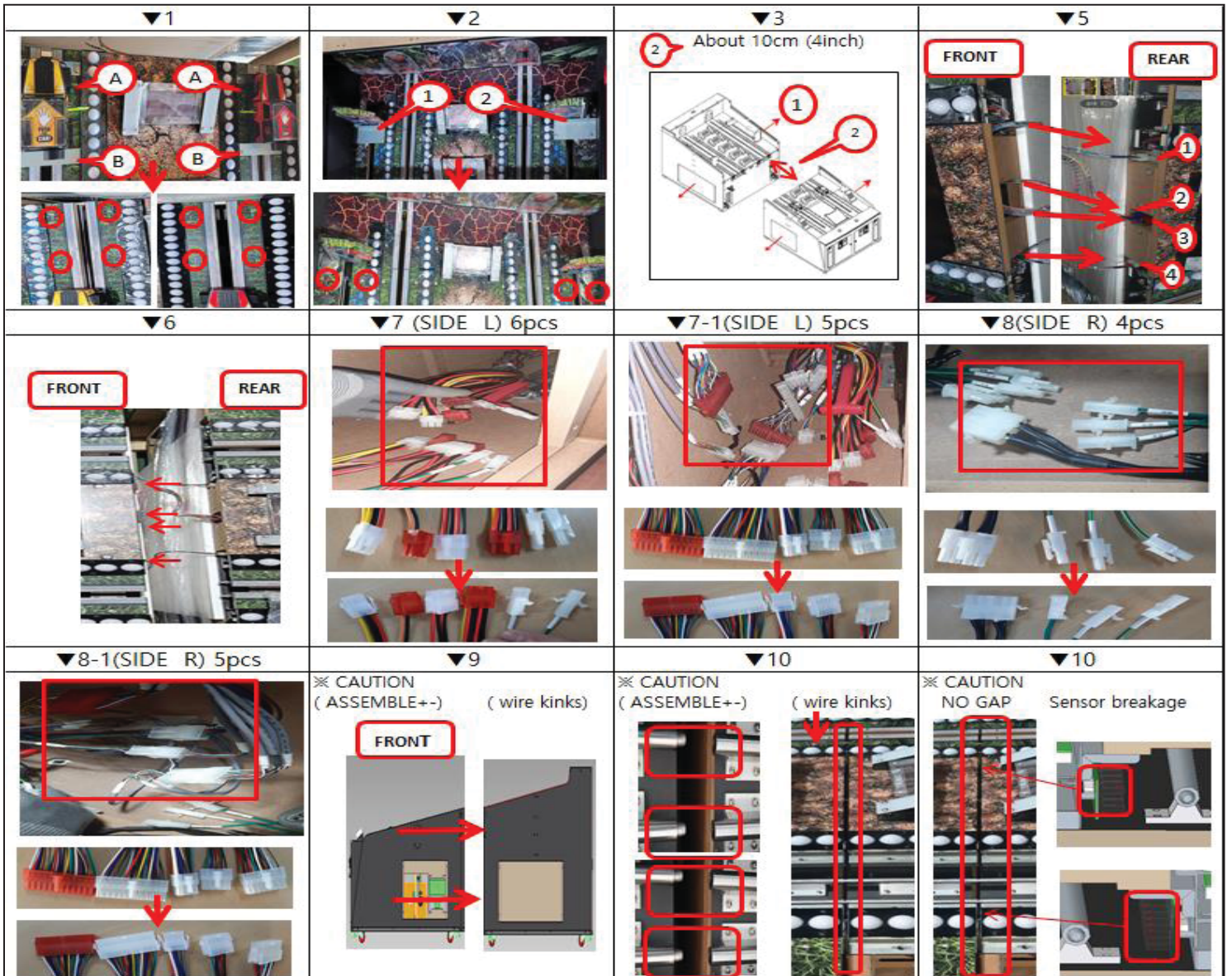

no	PROCESS	ITEM	Q'ty	BOLT	SPEC	Q'ty
11	LOCKING	TOGGLE CLAMP - L	2			
12	JOIN	NUT JOIN				12
13	LOCKING	TOGGLE CLAMP - R	2			
14	TIGHTEN	NUT JOIN				12
15	ASSEMBLE	UPPER CABINET	1	SEMS	6*16	7
	CONNECT	WIRING	1			
16	REMOVE	SUPPORT BKT L	1	LH_BL	6*20	3
	ASSEMBLE	SUPPORT BKT L	1	LH_BL	6*20	6
17	REMOVE	SUPPORT BKT R	1	LH_BL	6*20	3
	ASSEMBLE	SUPPORT BKT R	1	LH_BL	6*20	6

no	PROCESS	ITEM	Q'ty	BOLT	SPEC	Q'ty
18	ASSEMBLE	FND COVER ACRYL	1	TH_BL	4*8	14
19	REMOVE	WINDOW LOWER BKT-L	1	TH_BL	4*16	2
	ASSEMBLE	WINDOW LOWER BKT-L	1	TH_BL	4*16	3
20	REMOVE	WINDOW LOWER BKT-R	1	TH_BL	4*16	2
	ASSEMBLE	WINDOW LOWER BKT-R	1	TH_BL	4*16	3
21	REMOVE	DECO FIX BKT-L R	2	TH_BL	4*20	8
22	ASSEMBLE	CABINET PROTECT PART	1			
	CONNECT	WIRE	2			
	ASSEMBLE	PROTECT ACRLY	2	TH_WREN	4*16	2

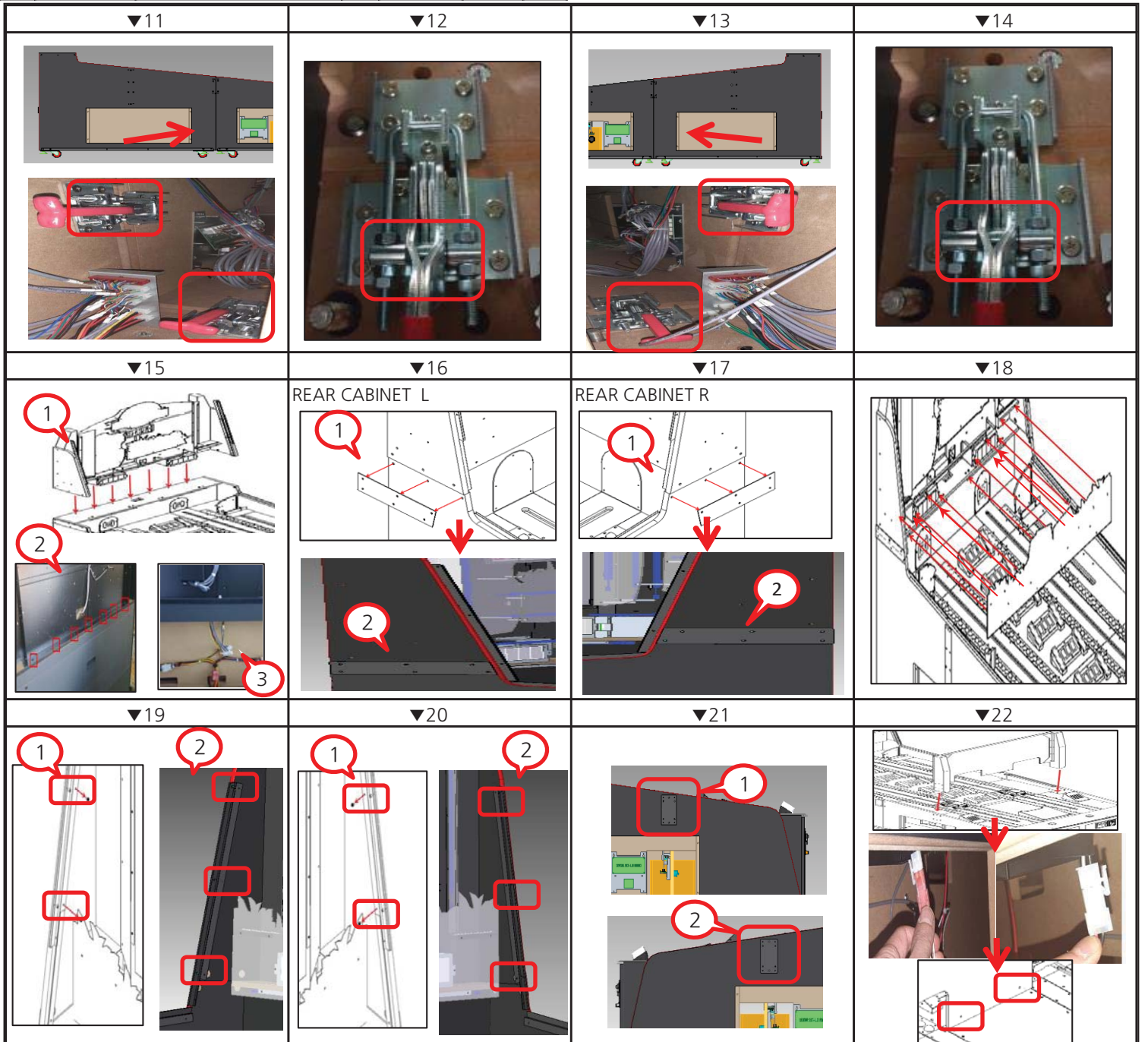

no	PROCESS	ITEM	Q'ty	BOLT	SPEC	Q'ty
23	ASSEMBLE	FRONT DECO FIX BKT L R	2	LH_BL TH_BL	6*35 4*20	12 8
24	CONNECT ASSEMBLE	WIRING CAR POINT LIGHT ASS'Y	1 1			
25	CONNECT ASSEMBLE	WIRING CAR POINT LIGHT ASS'Y	1 1			
26	REMOVE REMOVE	DECO FIX BKT-A DECO FIX BKT-B	2 2	TH_BL	4*20	8 8
27	ASSEMBLE ASSEMBLE	DECO BKT ASS'Y-A DECO BKT ASS'Y-B	2 2			

no	PROCESS	ITEM	Q'ty	BOLT	SPEC	Q'ty
28	ASSEMBLE ASSEMBLE	DECO FIX BKT-A DECO FIX BKT-B	2 2	LH_BL TH_BL	6*35 4*20	12 8
29	ASSEMBLE	WINDOW ACRYL-A,B,C	6			
30	ASSEMBLE ASSEMBLE ASSEMBLE	WINDOW ACRYL-A WINDOW ACRYL-B WINDOW ACRYL-C	2 2 2	TH_BL	4*12	12 12 12
31	TEST	AC POWER CORD JOIN → POWER ON				
32	ASSEMBLE	SIDE COVER PLATE	4	LH_BL	6*35	16
33	TIGHTEN	CASTETR	8			

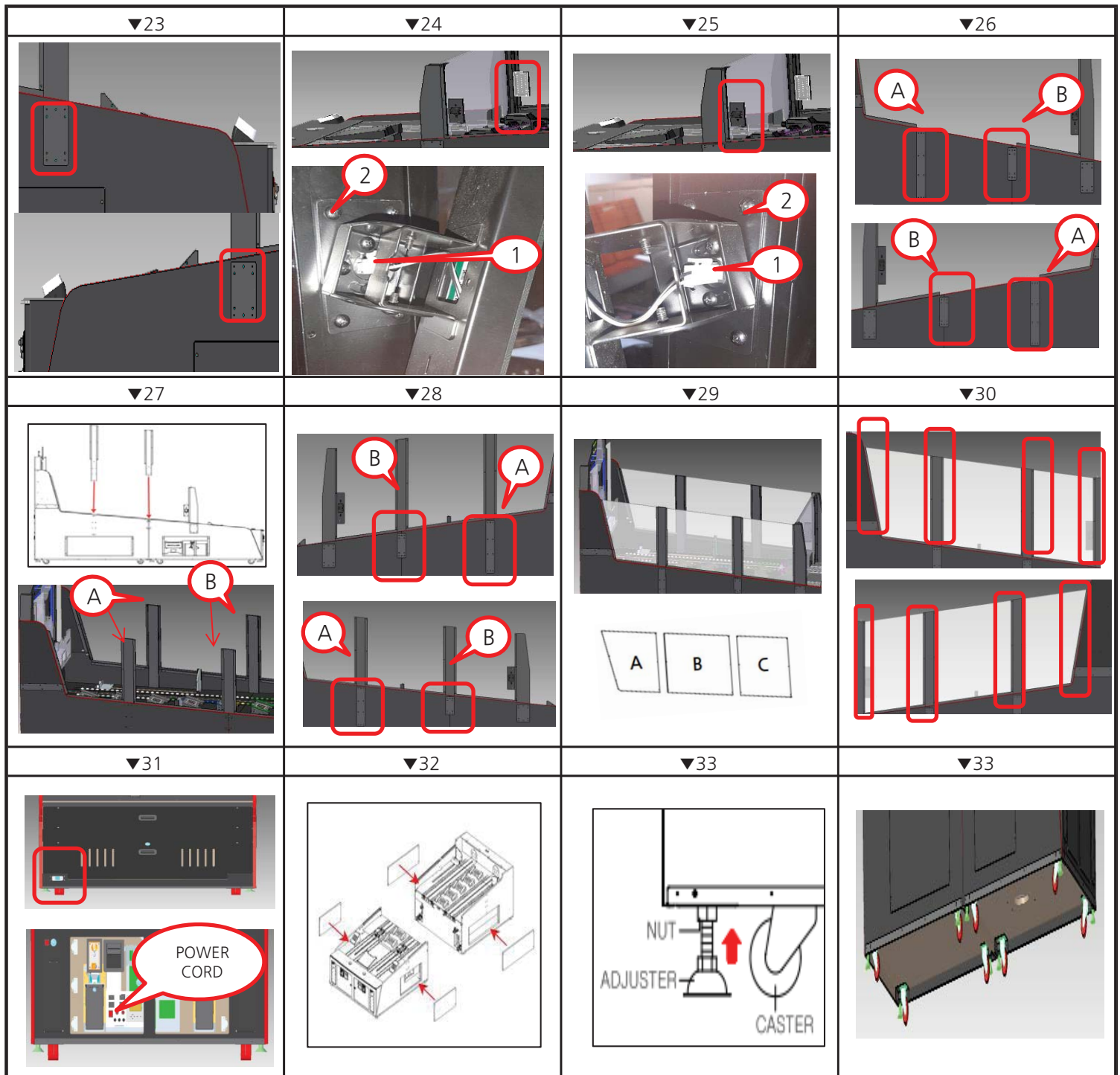

▶ OPTION : These pages replace numbers ▼7, ▼7-1, ▼8 and ▼8-1 above.

1. When there are two brackets to fix the wiring,

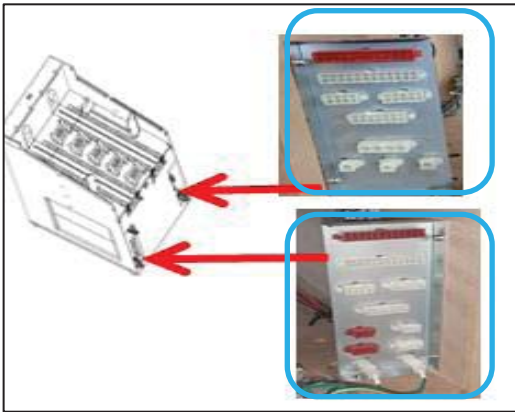

▼7	before (11 pin)	caution (3,8,9)	after
	<p>*caution : 3pcs (8 pin)</p> <p>The back front side</p>		
▼8	before(9 pin)		after(9 pin)

3. SETUP SETTING

3-1. MACHINE SETUP

1. SETUP BUTTON LAYOUT

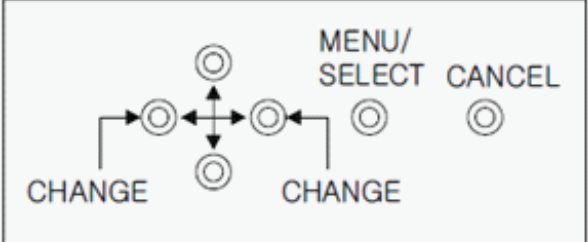
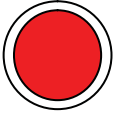
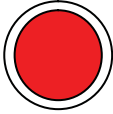
	<ol style="list-style-type: none"> 1) [↑↓] Up/Down Button : Menu Up/Down Move 2) [←→] Left/Right Button : Setting Value Change 3) Menu/Select Button : Execution of Set Up Menu Mode and Select 4) Cancel Button : Exit
<div style="display: flex; justify-content: space-around; align-items: center;"> <div style="text-align: center;">  <p>1P SERVICE/RESET</p> </div> <div style="text-align: center;">  <p>2P SERVICE/RESET</p> </div> </div>	<p>Normally service in. When error happens, Use this button to clear error.</p> <p>* Service in : To be increased by 1 credit per one press</p>

[OPERATING OPTIONS]

OPERATING OPTIONS	
Press MENU Button [MENU/SELECT Button: Enter]	
PROGRAM SETTINGS	Setting Mode
CLEAR MODE	Delete Mode
BOOKKEEPING DATA	Check Game Data
FACTORY SETTING	Initializing to Factory Setting
TEST MODE	Test Mode
EXIT	Exit to Operation options

3-2. SETUP MODE

PROGRAM SETTINGS			
LCD DISPLAY	DESCRIPTIONS	RANGE	DEFAULT
★CREDIT / COIN	SETTING RATIO OF CREDIT PER COIN	“FREE”, 1/1, 1/2, 1/3, 1/4, 1/5, 1/6, 1/7, 1/8, 1/9, 1/10, 2/1, 3/1, 4/1, 5/1	1/1
★PLAYS / BILL	SETTING CREDIT PER BILL INPUT	1, 2, 3, 4, 5, 6, 7, 8, 9, 10	1
CHEAT DETECT	SETTING FOR CHEATING PREVENTION WHEN JUDGED CHEATING, GAME END BY PROCESSING GAME OUT	“OFF”, “ON”	ON
CHEAT STOPTIME	SETTING REFERENCE TIME TO JUDGE SUDDEN STOP OF THE CAR BY CHEATING (TIME BETWEEN SENSORS JUST BEFORE CAR STOPS) (IT IS TO BE APPLIED WHEN CHEAT DETECT OPTION VALUE IS “ON”) (IT CAN NOT BE INITIALIZED AGAINST FACTORY SETTING) EXAMPLE) IN CASE OF SETTING VALUE 120, IF TIME BETWEEN SENSORS BEFORE STOP IS OVER 120 MS.IT IS OK. IF LESS THAN 120 MS, IT IS JUDGED AS CHEATING AND GAME ENDS	50 ~ 300 (MS), (increases by 10)	120
TIME OVER	SETTING FOR TIME OVER	10 ~ 99 (SECONDS), OFF	60
★SCORE TYPE ※ DIP	SETTING TICKET SCORE FOR LED LIGHT COLOR	=> (SUB MENU) (REFER TO TABLE#1)	
BIG - WIN VALUE ※ DIP	BIG WINFIRST STARTING VALUE	30 ~ 9999 (INCREASES BY 10)	1000
BIG - WIN LIMIT	BIG WIN MAXIMUM VALUE	30 ~ 9999 (INCREASES BY 50)	1500
BIG INCREMENT ※ DIP	BIG WIN INCREASE VALUE (INCREASE VALUE BY 1 PLAY)	0 ~ 50 (INCREASES BY 1)	1
BIG MOVE/PLAY	SETTING FREQUENCY OF MOVINGBIG WIN POSITION “HOLD” : FIXED POSITION OF BIG WIN “1/1”: MOVE BIG WIN POSITION AFTER 1 PLAY “1/2”: MOVE BIG WIN POSITION AFTER 2 PLAYS “1/5”: MOVE BIG WIN POSITION AFTER 5 PLAYS	“HOLD”, “1/1”, “1/2”, “1/3” “1/4”, “1/5”	1/1
BIG POSITION	SETTING POSITION OF BIG WIN WHEN BIG WIN IS FIXED POSITION TO BE APPLIED WHEN SETTING VALUE OF BIG MOVE/PLAY OPTION IS “HOLD”	27 ~ 45 (POSITION MEANS POSITION OF SLOPE LED #1 ~ #49 FROM THE FRONT OF THE MACHINE	45

DIFFICULTY	SETTING DIFFICULTY LEVEL (PATTERN CHANGE AT MOVEMENT OF BIG WIN POSITION) (IT SEEMS TO CHANGE +/- 5 TICKETS FROM AVERAGE TICKET PAYOUT) EASY: EASY PROCESS (+5), NORMAL: BASIC PROCESS (0) HARD: DIFFICULT PROCESS (-5)	EASY, NORMAL, HARD	NORMAL
TICKET/SCORE ※ DIP	SETTING TICKET RATIO PER SCORE NONE : AUTOMATIC DELETION OF TICKET COUNT WITHOUT DISPENSING TICKETS	"NONE", "1/1", "1/2"	1/1
ATTRACT VOLUME	SETTING USE OF DEMO SOUND AND VOLUME "OFF" : NO SOUND 10 ~ 100 : RATIO OF SOUND VOLUME	"OFF" , 10 ~ 100 (INCREASES BY 10)	80
SAVE AND EXIT	SAVE AND EXIT	PRESS SELECT BUTTON AND EXECUTE BY MOVING CURSOR TO (YES) or (NO)	
CANCEL AND EXIT	CANCEL AND EXIT		
<p>※ THE DEFAULT VALUE OF DIP DISPLAY ITEM CAN BE DIFFERENT ACCORDING TO DIP S/W SETTING (KSD08H)#3 & #4. FOR MORE DETAILS, PLEASE REFER TO DEFAULT VALUE OF DIP S/W SETTING.</p> <p>★ IF SETTING VALUE WITH (★) CHANGES, INTERNAL BOOKKEEPING DATA AND INFORMATION ABOUT GAME DATA & CREDIT & TICKET WILL BE DELETED.</p>			

<DIP S/W SETTING DEFAULT VALUE>

★ WHEN FACTORY SETTING, DEFAULT VALUE WILL BE DIFFERENT ACCORDING TO DIP S/W SETTING #3, #4. (REFER TO LOCATION OF ARROW IN YELLOW COLOR AT DIP S/W IN THE PHOTO)

※ When looking at the main board installed in the machine, please be careful because DIP S/W looks upside down at 180 degree.

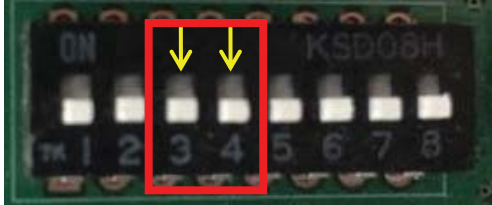

(Setting Criteria of DIP S/W)

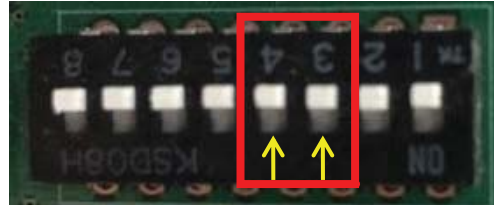

(DIP S/W when looking at the Main Board installed in the machine)

※ ACCORDING TO DIP S/W SETTING, THERE ARE 4 DIFFERENT TYPES (A, B, C, D TYPE)

	A		B		C		D	
DIP 3	OFF		ON		OFF		ON	
DIP 4	OFF		OFF		ON		ON	
SCORE TYPE	TYPE	12	TYPE	12	TYPE	2	TYPE	12
	GAME OUT	6	GAME OUT	6	GAME OUT	1	GAME OUT	6
	YELLOW	60	YELLOW	60	YELLOW	10	YELLOW	60
	GREEN	40	GREEN	40	GREEN	5	GREEN	40
	CYAN	30	CYAN	30	CYAN	3	CYAN	30
	BLUE	20	BLUE	20	BLUE	2	BLUE	20
BIG-WIN VALUE	1000		1000		100		1000	
BIG-WIN INCREMENT	2		1		1		1	
TICKET/SCORE	1/2		1/1		1/1		1/1	

<DIP S/W SETTING DEFAULT VALUE_SLOPE SENSOR EXT IO PCB ASS'Y>

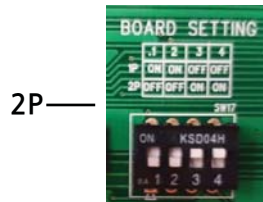
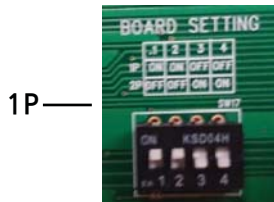

<TABLE #1>

- PROGRAM SETTINGS -> SCORE TYPE
 - ◇ SETTING TICKET SCORE BY TYPE ACCORDING TO THE COLOR OF LED LIGHT
- CHANGE SCORE AND TYPE BY SETTING DEFAULT TYPE.
SEPARATELY INDIVIDUAL SCORE SETTING BY COLOR IS POSSIBLE

LCD DISPLAY	DESCRIPTIONS	RANGES	DEFAULT
TYPE	REFERENCE SCORE TABLE BASICALLY SET INTERNALLY	1 ~ 14 (INCREASES BY 1)	12
GAME OUT	GAME OUTSCORE SETTING	1 ~ 99 (INCREASES BY 1)	6
YELLOW	LED LIGHT-YELLOW COLOR SCORE SETTING	1 ~ 999 (INCREASES BY 1)	60
GREEN	LED LIGHT-GREEN COLOR SCORE SETTING		40
CYAN	LED LIGHT-CYAN COLOR SCORE SETTING		30
BLUE	LED LIGHT-BLUE COLOR SCORE SETTING		20
SAVE AND EXIT	SAVE AND EXIT	PRESS SELECT BUTTON AND EXECUTE BY MOVING THE CURSOR TO (YES) or (NO)	
CANCEL AND EXIT	CANCEL AND EXIT		

<TYPE LAYOUT>* ONE FND CONSISTS OF SEVEN SLOPE LEDS (TOTAL 49 SLOPE LEDS)

GAME OUT		
SLOPE	FND 7	BLUE
	FND 6	CYAN
	FND 5	GREEN
	FND 4	YELLOW
	FND 3	CYAN
	FND 2	BLUE
	FND 1	BLUE
START BUTTON		

<INTERNAL SCORE SETTING VALUE BY TYPE>

TYPE	1	2	3	4	5	6	7	8	9	10	11	12	13	14
AVERAGE	3	5	10	15	20	25	30	35	40	45	50	60	70	80
BIG WIN	50	100	100	200	300	300	500	500	500	500	700	1000	1000	1000
GAMEOUT	1	1	2	2	2	2	2	2	2	2	2	6	6	10
YELLOW	5	10	20	20	20	30	30	40	50	60	60	60	60	70
GREEN	4	5	12	12	12	20	20	20	30	30	30	40	50	60
CYAN	3	3	8	8	8	8	8	12	20	20	20	30	40	50
BLUE	2	2	4	4	4	4	4	8	10	10	10	20	30	40

★ SCORE TYPE IS NOT INITIALIZED AGAINST FACTORY SETTING. IN CASE DIP S/W #3 & #4 WAS CHANGED, SCORE TYPE IS INITIALIZED ONCE FOR THE FIRST TIME WHEN FACTORY SETTING.

3-3. CLEAR MODE

● CLEAR MODE		
✧ GAME DATA & BOOKKEEPING CAN BE DELETED		
LCD DISPLAY	DESCRIPTION	EXECUTION
CLEAR TICKETS	DELETE CURRENT TICKET COUNT TO BE DISPENSED NOW	PRESS SELECT BUTTON AND EXECUTE BY MOVING THE CURSOR TO (YES) or (NO)
CLEAR PLAYS	DELETE CURRENT PLAY	
CLEAR DATA	DELETE BOTH GAME DATA AND BOOKKEEPING DATA	
EXIT	EXIT	

● BOOKKEEPING	
LCD DISPLAY	DESCRIPTION
1P : 1 Player 2P : 2 Player TOTAL : 1P AND 2P	
-- COIN IN -- 1P : 0 2P : 0 TOTAL : 0	EACH PLAYER AND TOTAL COIN IN
-- BILL IN -- 1P : 0 2P : 0 TOTAL : 0	EACH PLAYER AND TOTAL BILL IN
-- SERVICE IN -- 1P : 0 2P : 0 TOTAL : 0	EACH PLAYER AND TOTAL SERVICE IN. INCREASES BY 1 PLAY WHEN PRESSING SERVICE IN
-- GAME PLAYS -- 1P : 0 2P : 0 TOTAL : 0	EACH PLAYER AND TOTAL NUMBER OF GAME PLAY
-- TICKET OUT -- 1P : 0 2P : 0 TOTAL : 0	EACH PLAYER AND TOTAL NUMBER OF TICKET OUT
-- BIG WIN -- 1P : 0 2P : 0 TOTAL : 0	EACH PLAYER AND TOTAL NUMBER OF WINNING "BIG WIN"
-- GAME OUT -- 1P : 0 2P : 0 TOTAL : 0	EACH PLAYER AND TOTAL NUMBER OF GAME OUT

-- WIN YELLOW -- 1P : 0 2P : 0 TOTAL : 0	EACH PLAYER AND TOTAL NUMBER OF WINING YELLOW COLOR
-- WIN GREEN -- 1P : 0 2P : 0 TOTAL : 0	EACH PLAYER AND TOTAL NUMBER OF WINNING GREEN COLOR
-- WIN CYAN -- 1P : 0 2P : 0 TOTAL : 0	EACH PLAYER AND TOTAL NUMBER OF WINNING CYAN COLOR
-- WIN BLUE -- 1P : 0 2P : 0 TOTAL : 0	EACH PLAYER AND TOTAL NUMBER OF WINNING BLUE COLOR
** SYSTEM DATA ** POWER: 0, 0:00	DISPLAY OF SYSTEM DATA NUMBER OF MACHINE START AND TIME THAT MACHINE IS SWITCHED ON
** VER INFO ** V_.___ LED IO Ver __	DISPLAY OF VERSION INFORMATION - PROGRAM VERSION OF MAIN BOARD AND DATE - LED IO BOARD FIRMWARE VERSION
CANCELBUTTON: EXIT	

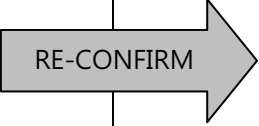
<ul style="list-style-type: none"> ● FACTORY-SETTING INITIALIZES TO FACTORY SETTING (CLEARING TOTAL DATA AND SETTING DEFAULT VALUE) ★ SETTING VALUE OF SCORE TYPE WILL NOT BE INITIALIZED AGAINST FACTORY SETTING 	
LCD DISPLAY (EXECUTION)	LCD DISPLAY (EXECUTION)
FACTORY-SETTING ARE YOU SURE? YES or [<u>NO</u>] EXECUTE BY MOVING THE CURSOR	FACTORY-SETTING REALLY ? YES or [<u>NO</u>] EXECUTE BY MOVING THE CURSOR
	

3-4. TEST MODE

TEST MODE			
TEST ITEMS	SET UP ITEMS	DESCRIPTION	
INPUT TEST	[=>]	ENTER INTO CHECK MODE OF INPUT STATUS	
		DISPLAY OF INPUT STATUS OF EACH ITEM AT LCD (BUTTON, COIN, TICKET, SENSOR... ETC)	
FND & LAMP	LAMP, FND, LED OPERATION TEST		
	"OFF"	TOTAL OFF	
	<u>"STEP"</u>	LAMP	<ul style="list-style-type: none"> ▶ TOTAL ON, OFF FLICKERING ▶ BOTTOM LAMP ON ▶ 1P/2P TICKET LAMP ON ▶ 1P/2P START BUTTON LAMP ON ▶ HOW TO LAMP ON ▶ 1P/2P CAR SPOT LAMP ON ▶ 1P/2P RETRY LAMP ON ▶ BILLBOARD LAMP ON REPEATS IN ABOVE SEQUENCE
		FND	<ul style="list-style-type: none"> ▶ TOTAL ON, OFF FLICKERING ▶ TOTAL NUMBER COUNT [0000] ~ [9999] ▶ CREDIT 1P [00] / 2P [11], RETRY 1P [22] / 2P [33] ▶ TICKET 1P [4444] / 2P [5555] ▶ SCORE [000] ~ [666], BIGWIN [7777] REPEATS IN ABOVE SEQUENCE
		LED	<ul style="list-style-type: none"> ▶ TOTAL WHITE ON, OFF FLICKERING ▶ TURNING ON IN SEQUENCE OF 1P LED RED / 2P LED BLUE ▶ TURNING ON IN SEQUENCE OF RED ▶ GREEN ▶ BLUE ▶ WHITE
	"ON"	TOTAL ON	
"ON/OFF"	REPEATION OF TOTAL ON, OFF		
SLOPE SENSOR	=>	ENTER INTO CHECK MODE OF SLOPE SENSOR STATUS	
	SLOPE SENSOR DETAIL FEDCBA9876543210 EX0:0000000000000000 EX1:0000000000000000 EX2:0000000000000000 EX3:0000000000000000 EX4:0000000000000000 EX5:0000000000000000 EX6:0000000000000000 EX7:0000000000000000	DISPLAY OF INPUT STATUS OF I/O EXPANSION BOARD WITH 0 AND 1. 0 - NOT SENSING SENSOR SIGNAL 1 - SENSOR SIGNAL DETECTED SLOPE LED : DISPLAY OF SENSOR STATUS #1~#50 BY LED COLOR WHITE COLOR - NOT SENSING SENSOR SIGNAL RED COLOR - SENSOR SIGNAL DETECTED RETRY FND [■ ■] : DISPLAY OF DETECTED SENSOR NO SCORE FND TOP [■ ■ ■] : DISPLAY OF SLOPE SENSOR (On, Err) SCORE FND BOTTOM [□ ■ ■] : DISPLAY OF SENSOR NO IN ERROR	
	◎ UP/DOWN OPERATION OF STOPPER WITH 1P,2P START BUTTON SLOPE LED: DISPLAY OF SENSOR STATUS BY LED COLOR WHITE: NOT SENSING SENSOR SIGNAL RED: SENSOR SIGNAL DETECTED RETRY FND : DISPLAY OF DETECTED SENSOR NO		

MOT BIGWIN	OPERATION TEST OF BIG WIN MOTOR ◎ SELECT TYPE WITH LEFT/RIGHT BUTTON AND THEN PRESS SELECT BUTTON ◎ AUTOMATIC REPEAT OF FORWARD & BACKWARD OF BIG WIN MOVEMENT DEVICE	
	"ALL"	OPERATION OF 1P, 2P BIG WIN MOTOR
	"1P"	OPERATION OF 1P BIG WIN MOTOR
	"2P"	OPERATION OF 2P BIG WIN MOTOR
	SCORE FND TOP [■ ■ ■] : DISPLAY OF MOTOR OPERATION STATUS ON, OFF AND ERROR "E.3x" SCORE FND BOTTOM [■ □ □] : DISPLAY OF #1 (UP) LIMIT SENSOR STATUS (0, 1) [□ ■ □] : DISPLAY OF POSITION SENSOR STATUS (0, 1) [□ □ ■] : DISPLAY OF #2 (DOWN) LIMIT SENSOR STATUS (0, 1) RETRY FND [■ ■] : DISPLAY OF POSITION SENSOR CHECK COUNT	
MOT STOPPER	OPERATION TEST FOR STOPPER MOTOR ◎ SELECT TYPE WITH LEFT/RIGHT BUTTON AND THEN PRESS SELECT BUTTON ◎ ALTERNATE OPERATION OF ASCENT AND DESCENT OF STOPPER MOTOR	
	"ALL"	OPERATION OF 1P, 2P STOPPER MOTOR
	"1P"	OPERATION OF 1P STOPPER MOTOR
	"2P"	OPERATION OF 2P STOPPER MOTOR
	SCORE FND TOP [■ ■ ■] : DISPLAY OF MOTOR OPERATION On, Off and ERROR "E.4x" SCORE FND BOTTOM [■ □ □] : DISPLAY OF STATUS OF ENCORDER STARTING POINT SENSOR (0, 1) [□ □ ■] : DISPLAY OF STATUS OF ENCORDER EQUINOX SENSOR (0, 1) CREDIT FND [■ ■] : DISPLAY OF CHECK COUNT OF ENCORDER EQUINOX SENSOR TICKET FND [■ ■ ■ ■] : DISPLAY OF MOVEMENT TIME FOR INCREASE (BY 1MS)	
COIN	COIN SELECTOR OPERATION TEST ◎ WHEN PRESSING SELECT BUTTON, 1P AND 2P OPERATE ON, OFF SIMULTANEOUSLY ◎ WHEN PRESSING START BUTTON , 1P AND 2P OPERATES ON, OFF SEPARATELY	
	"ON", "OFF"	COIN SELECTOR OPERATION ON, OFF
	SCORE FND TOP [■ ■ ■] : OPERATION STATUS OF COIN SELECTOR, DISPLAY OF ON, OFF AND ERROR "Err" SCORE FND BOTTOM [□ □ ■] : DISPLAY OF COIN SENSOR STATUS (0 or 1) CREDIT FND [■ ■] : DISPLAY OF COIN SENSOR CHECK COUNT (00 ~ 99 REPEATS)	
BILL	OPERATION TEST OF BILL ACCEPTER ◎ WHEN PRESSING SELECT BUTTON, 1P AND 2P OPERATES ON, OFF SIMULTANEOUSLY ◎ WHEN PRESSING START BUTTON, 1P AND 2P OPERATES ON, OFF SEPARATELY	
	"ON", "OFF"	BILL ACCEPTER OPERATION ON, OFF
	SCORE FND TOP [■ ■ ■] : OPERATION STATUS OF BILL ACCEPTER, DISPLAY OF ON, OFF AND ERROR "Err" SCORE FND BOTTOM [□ □ ■] : DISPLAY OF BILL ACCEPTER SENSOR STATUS (0 or 1) CREDIT FND [■ ■] : DISPLAY OF BILL ACCEPTER SENSOR CHECK COUNT (00 ~ 99 REPEATS)	

TICKET	OPERATION TEST OF TICKET DISPENSER ◎ SELECT TYPE WITH LEFT, RIGHT BUTTON AND PRESS SELECT BUTTON TO TEST ◎ TICKET BUTTON OF 1P AND 2P OPERATES SEPARATELY (DISPENSES 3 TICKETS)	
	"ALL"	OPERATION TEST OF ALL PLAYERS (DISPENSES 3 TICKETS)
	"1P", "2P"	INDIVIDUAL OPERATION TEST OF 1P AND 2P (3 TICKETS)
	SCORE FND TOP [■ ■ ■] : OPERATION STATUS OF TICKET DISPENSER, DISPLAY OF ON, OFF AND ERROR "Err" SCORE FND BOTTOM [□ □ ■] : DISPLAY OF NUMBER OF TICKETS DISPENSED CREDITFND [■ □] : DISPLAY OF TICKET BUTTON STATUS (0, 1) [□ ■] : DISPLAY OF TICKET DISPENSER SENSOR STATUS (0, 1)	
COUNTER	COUNTER TEST ◎ AFTER SELECTING TYPE WITH LEFT, RIGHT BUTTON, PRESS SELECT BUTTON AND THEN IT CREASES BY 1 ◎ COUNTER INCREASES BY ONE WH PRESSING 1P/2P SERVICE BUTTON	
	"COIN"	OPERATION OF COIN COUNER OF ALL PLAYERS INCREASES BY "1" IN ORDER OF 1P → 2P
	"TICKET"	OPERATION OF TICKET COUNTER OF ALL PLAYERS INCREASES BY "1" IN ORDER OF 1P → 2P
SOUND TEST	SOUND TEST ◎ AFTER SELECTING TYPE WITH LEFT, RIGHT BUTTON AND PRESS SELECT TO TEST (PLAY, STOP)	
	"CH"	VOICE OUTPUT PER EACH CHANNEL SPEAKER ONE, TWO ~ EIGHT LEFT : 1, 3, 5, 7 RIGHT : 2, 4, 6, 8
	"BGM"	OUTPUT TEST OF BACKGROUND MUSIC
	"SFX"	OUTPUT TEST OF EFFECT MUSIC
	"VOC"	VOICE OUTPUT TEST
EXIT	EXIT TO OPERATING OPTIONS	

3-5. ERROR CODE

- ALL GAMES STOP WHEN ERROR “Er.02” AND “Er.03” HAPPEN BUT GAME WILL BE CONTINUED AGAINST ALL OTHER ERRORS, EXCEPT FOR THE PLAYER WITH ERROR. (TICKET ERROR “HELP” DOES NOT STOP THE GAME)

ERROR CODE	ERROR TYPE	CONTENTS	CHECK POINTS
Er.02	SYSTEM	PROBLEM AT SETUP SAVE DATA	1. CHECK SET UP STATUS AND SAVE 2. DO FACTORY SETTING 3. CHECK POWER ON, OFF 4. REPLACE MAIN BOARD IF PROBLEM IS STILL NOT SOLVED
Er.03		PROBLEM AT GAME SAVE DATA	1. CLEAR DATA AT SET UP CLEAR MODE 2. CHECK POWER ON, OFF 3. REPLACE MAIN BOARD IF PROBLEM IS STILL NOT SOLVED
Er.11	COIN SELECTOR	CONTINUOUS EXISTENCE OF COIN SENSOR SIGNAL	CHECK COIN SELECTOR SENSOR INPUT OF THE PLAYER IN ERROR
Er.13	BILL ACCEPTER	CONTINUOUS EXISTENCE OF BILL ACCEPTER SENSOR SIGNAL	CHECK BILL ACCEPTER SENSOR INPUT OF THE PLAYER IN ERROR
Er.31	BIG WIN MOTOR	CONTINUOUS EXISTENCE OF #1 (UP) LIMIT SENSOR	1. CHECK OPERATION STATUS OF MOTOR 2. CHECK INPUT STATUS OF SENSOR
Er.32		CONTINUOUS EXISTENCE OF #2 (DOWN) LIMIT SENSOR	1. CHECK OPERATION STATUS OF MOTOR 2. CHECK INPUT STATUS OF MOTOR
Er.33		NO CHANGE OF POSITION SENSOR SIGNAL	1. CHECK OPERATION STATUS OF MOTOR 2. CHECK INPUT STATUS OF SENSOR
Er.34		ABNORMAL POSITION SENOR SIGNAL	1. CHECK CHECKER BRACKET STATUS 2. CHECK INPUT STATUS OF SENSOR
Er.41	STOPPER MOTOR	NO ENCODER EQUINOX SIGNAL	1. CHECK OPERATION STATUS OF MOTOR 2. CHECK ENCODER SENSOR INPUT STATUS
Er.42		NO ENCODER STARTING POINT SIGNAL	1. CHECK OPERATION STATUS OF MOTOR 2. CHECK ENCODER SENSOR INPUT STATUS

Er.51	SLOPE SENSOR	CONTINUS EXISTENCE OF SENSOR SIGNAL	1. CHECK OPERATION STATUS OF CAR 2. CHECK INPUT STATUS OF SENSOR.
Er.52		CAR STOPS WHILE MOVING	1. CHECK OPERATION STATUS OF CAR 2. CHECK STATUS OF SENSOR INPUT
Er.53		ABNORMAL IN SEQUENCE OF SENSOR	1. CHECK STATUS OF SENSOR INPUT 2. CHECK WIRING STATUS OF SENSOR
HELP	TICKET ERROR	NO TICKETS	1. CHECK TICKETS 2. CHECK OPERATION OF TICKET MOTOR 3. CHECK TICKET DISPENSING SENSOR
<p>- ERROR CODE IS DISPLAYED AT TICKET FND / RETRY FND OF THE PLAYER WITH ERROR (FOR DISPLAY OF ERROR CODE, PLEASE REFER TO DESCRIPTION ITEMS OF TEST MODE)</p>			

- ERROR CODE& ERROR DETECTION METHOD

ERROR CODE	ERROR TYPE	CONTENTS	ERROR CHECK CONDITION
Er.02	SYSTEM	PROBLEM AT SETUP SAVE DATA	AFTER POWER IS TURNED ON, CHECK BACK-UP MEMORY RELATED WITH MAIN BOARD SETUP
Er.03		PROBLEM AT GAME SAVE DATA	AFTER POWER IS TURNED ON, CHECKBACK-UP MEMORY RELATED WITH MAIN BOARD GAME
Er.11	COIN SELECTOR	CONTINUOUS EXISTENCE OF COIN SENSOR SIGNAL	SIGNAL KEEPS ON FOR MORE THAN TWO SECONDS WHEN INHIBIT IS ON
Er.13	BILL ACCEPTER	CONTINUOUS EXISTENCE OF BILL ACCEPTER SENSOR SIGNAL	SENSOR SIGNAL KEEPS ON FOR MORE THAN TWO SECONDS
Er.31	BIG WIN MOTOR	CONTINUOUS EXISTENCE OF #1 (UP) LIMIT SENSOR	SENSOR SIGNALS KEEPS ON FOR MORE THAN 4 SECONDS
Er.32		CONTINUOUS EXISTENCE OF #2 (DOWN) LIMIT SENSOR	SENSOR SIGNAL KEEPS ON FOR MORE THAN 4 SECONDS
Er.33		NO CHANGE AT POSITION SENSOR SIGNAL	NO CHANGE AT SENSOR SIGNAL FOR MORE THAN 4 SECONDS DURING OPERATION OF MOTOR
Er.34		ABNORMALITY AT POSITION SENOR SIGNAL	CONDITION OF POSITION SENSOR COUNT IS NOT MET DURING BOOT TEST
Er.41	STOPPER MOTOR	NO ENCODER EQUINOX SIGNAL	NO SIGNAL FROM ENCODER EQUINOX FOR MORE THAN 0.5 SECOND WHILE MOTOR IS BEING OPERATED (DISPLAY OF ERROR AFTER 3 TIMES REVERSE-ROTAING)
Er.42		NO ENCODER STARTING POINT SIGNAL	NO SIGNAL FROM ENCODER STARTING POINT SENSOR FOR OVER 3 SECONDS DURING INCREASE OPERATION

Er.51	SLOPE SENSOR	CONTINUS EXISTENCE OF SENSOR SIGNAL	SENSOR SIGNAL KEEPS ON FOR MORETHAN THREE SECONDS
Er.52		CAR STOPS WHILE MOVING	NO SIGNAL FOR OVER 10 SECONDS WHILE CAR IS MOVING
Er.53		ABNORMAL IN SEQUENCE OF SENSOR	NO RECOGNIZING THE SIGNAL ACCORDING TO SEQUENCE OF SENSOR WHILE MOVING THE CAR
HELP	TICKET ERROR	NO TICKETS	NO TICKET SENSOR SIGNAL FOR MORE THAN ONE SECOND WHILE DISPENSING TICKETS

4. TROUBLESHOOTING

* General check up : Check the supply voltage and wiring connection properly
 * "NO" : Means faulty of the check up result.

4-1. BIGWIN MOTOR ERROR [Er. 31 or Er. 32]

BIGWIN MOTOR

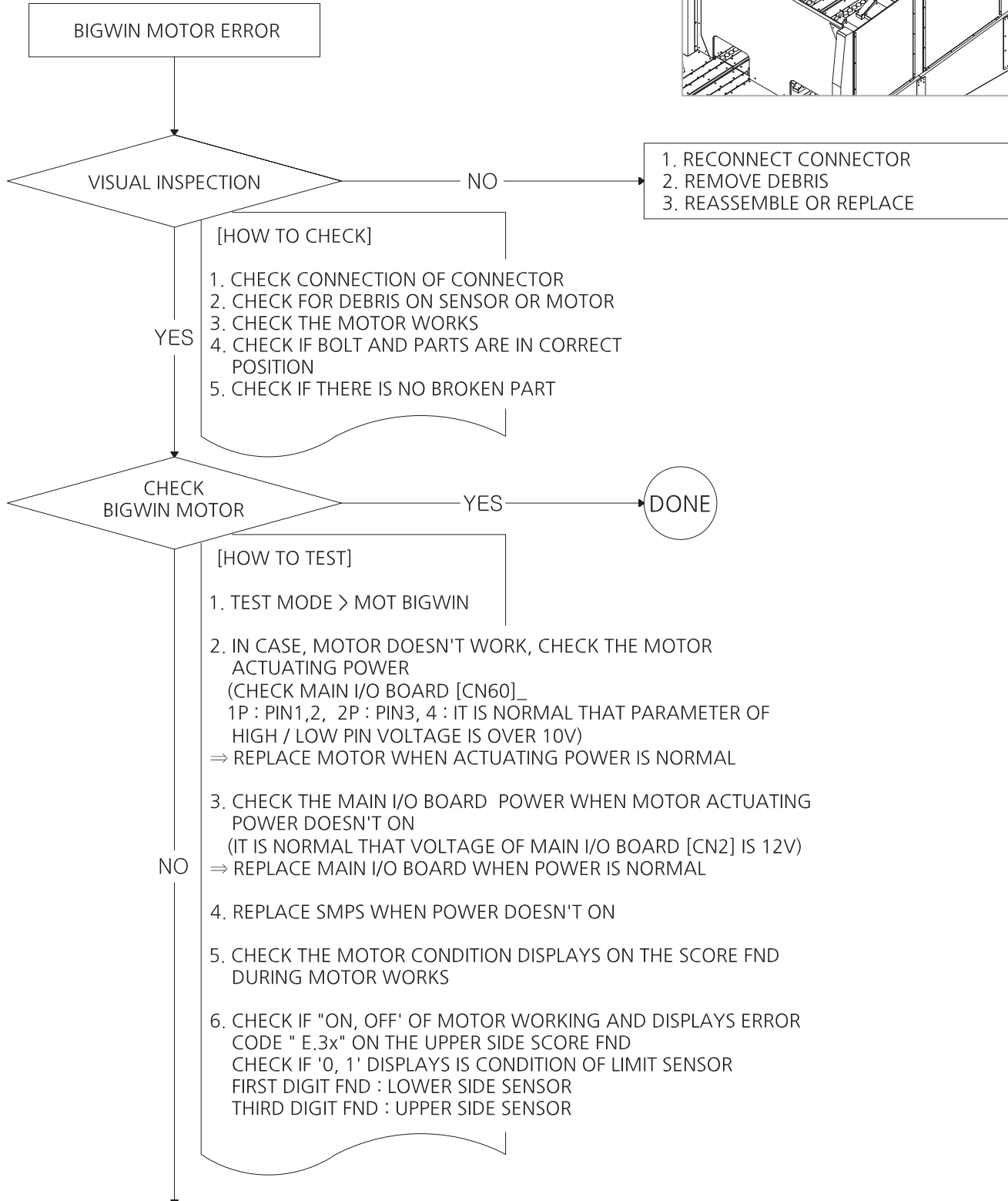
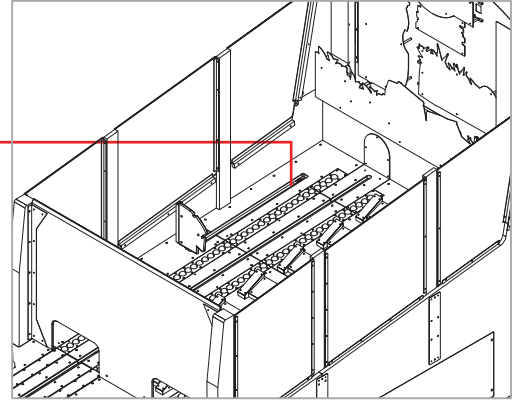

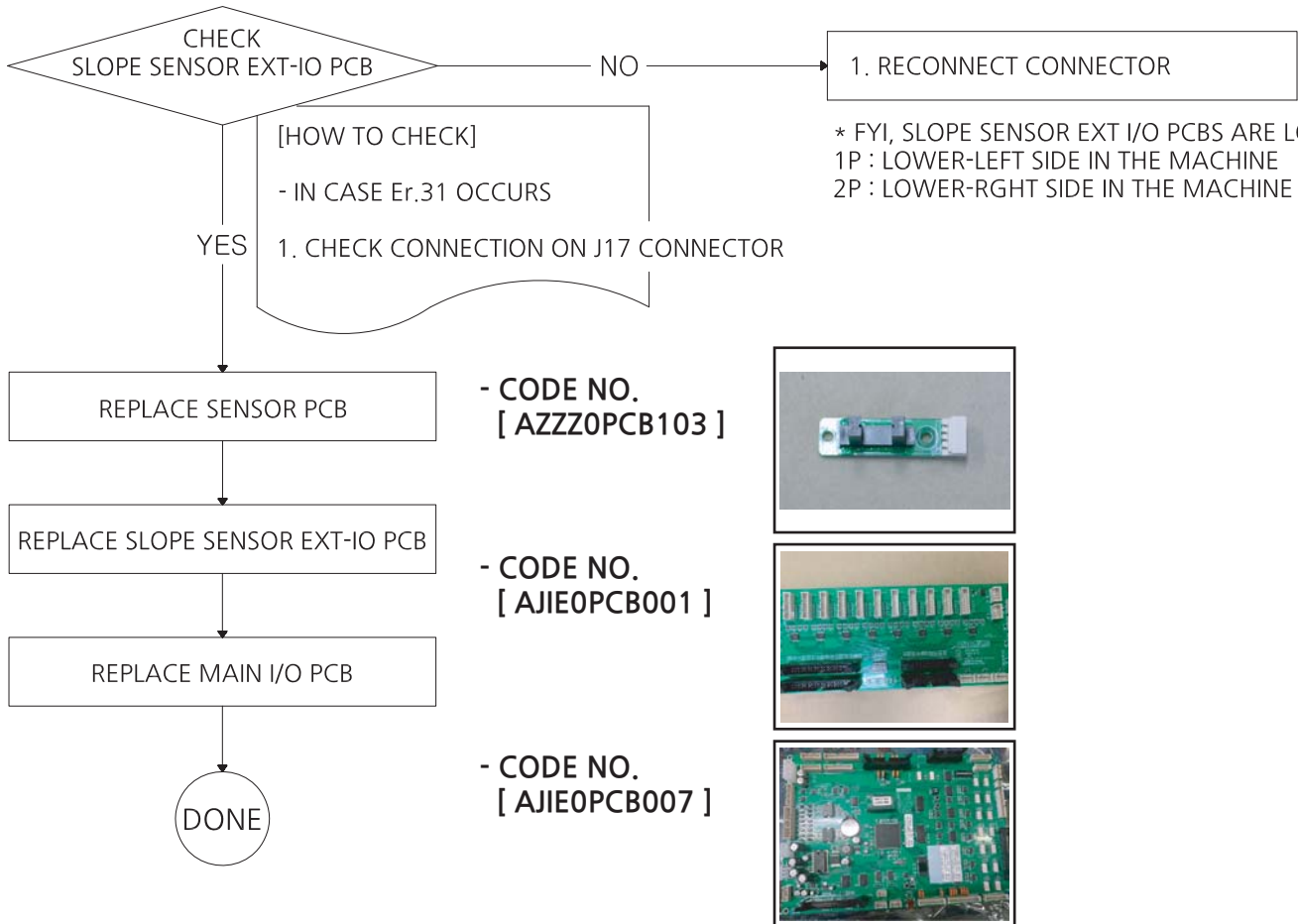

* General check up : Check the supply voltage and wiring connection properly
 * "NO" : Means faulty of the check up result.

4-2. BIGWIN MOTOR ERROR [Er. 33 or Er. 34]

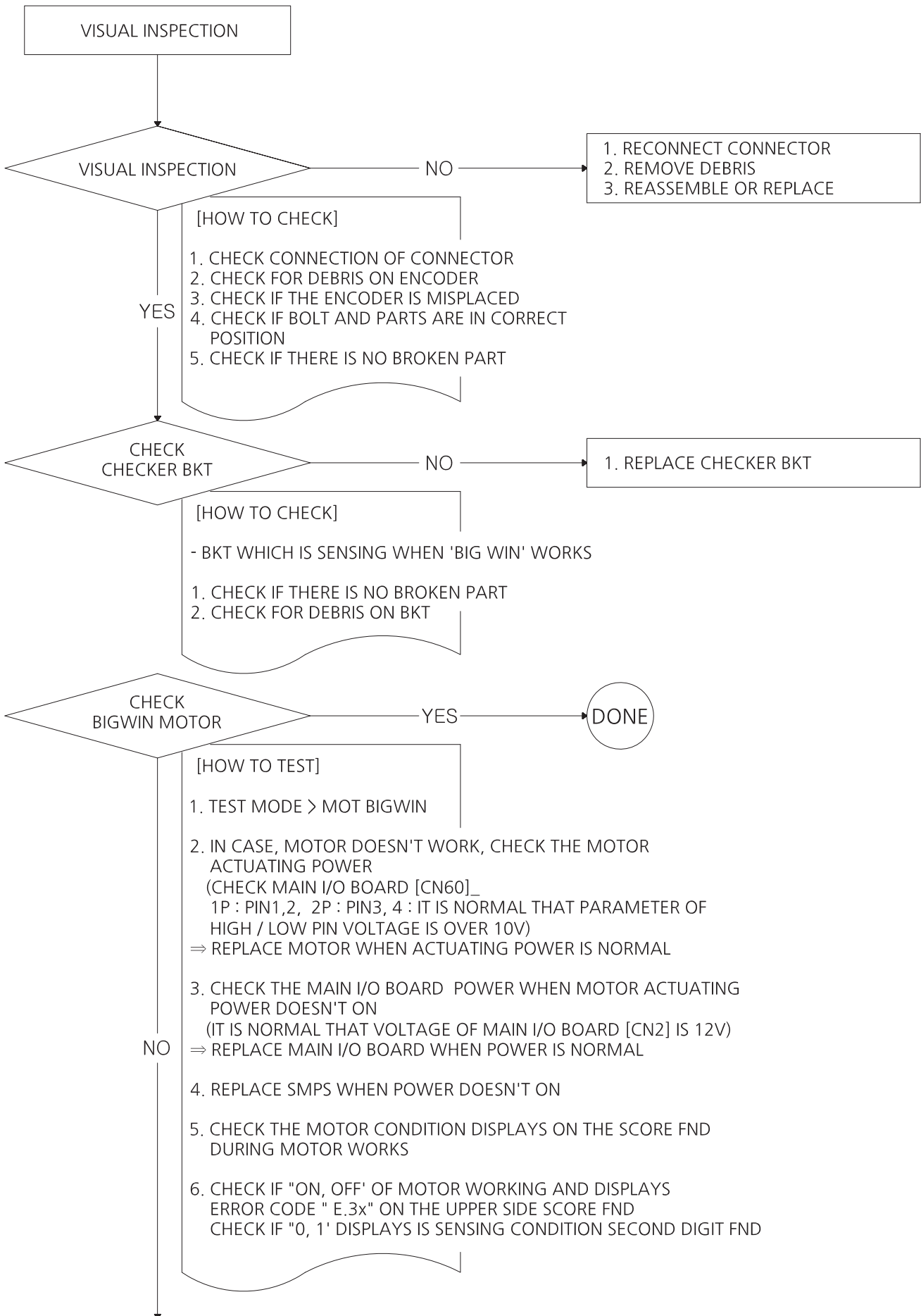

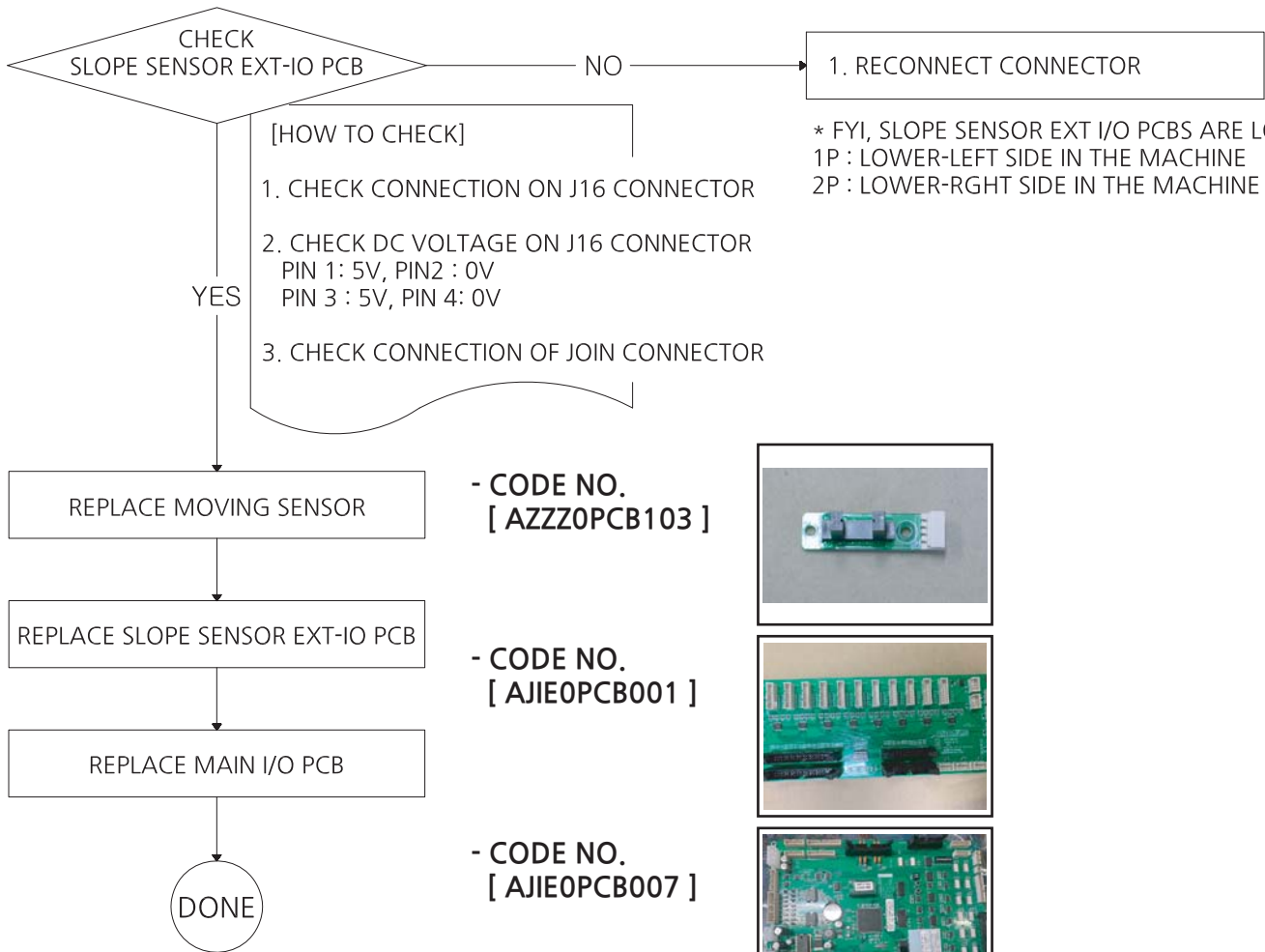

* General check up : Check the supply voltage and wiring connection properly
 * "NO" : Means faulty of the check up result.

4-3. SLOPE SENSOR ERROR [Er. 51 or Er. 52]

SLOPE SENSOR

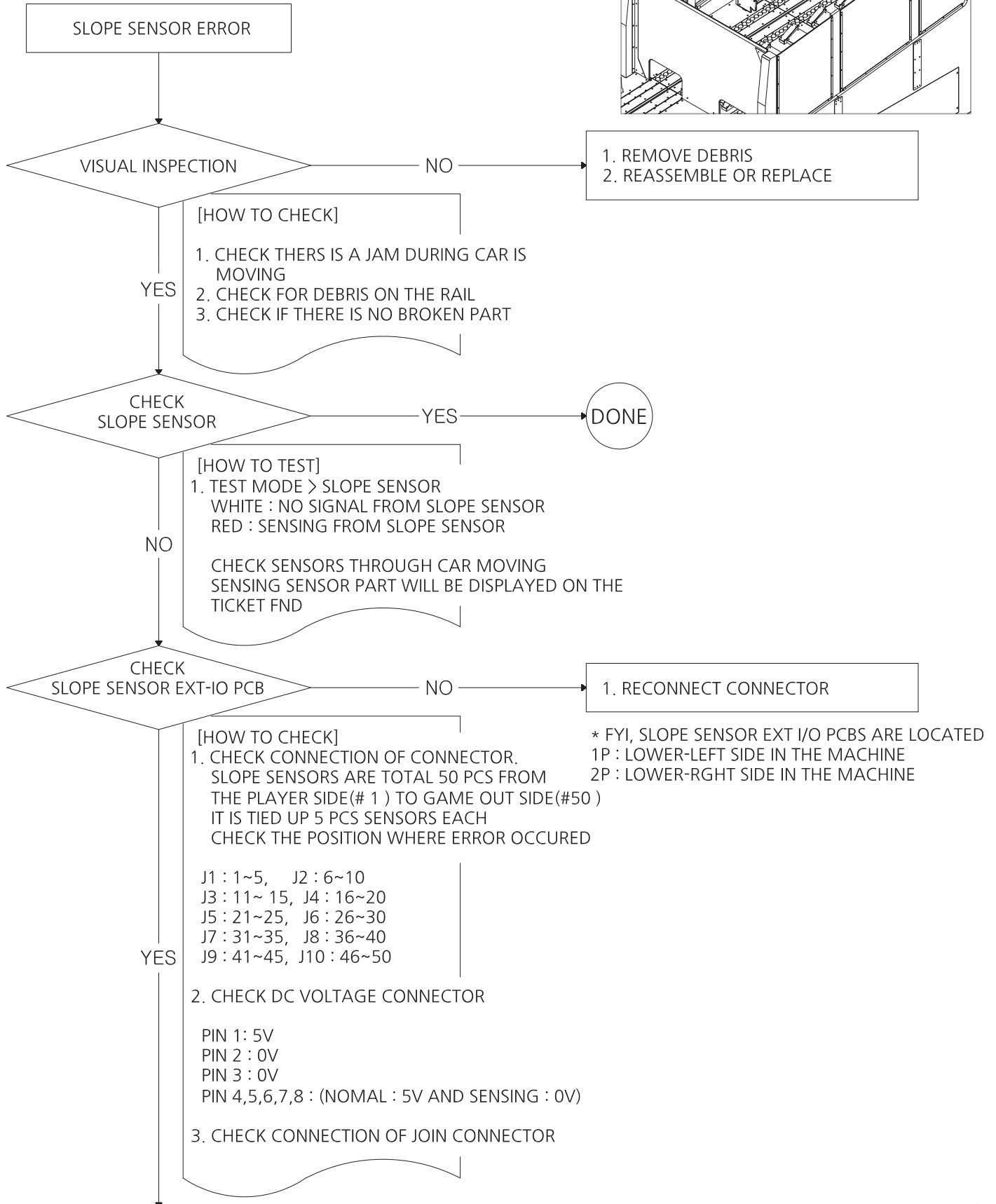
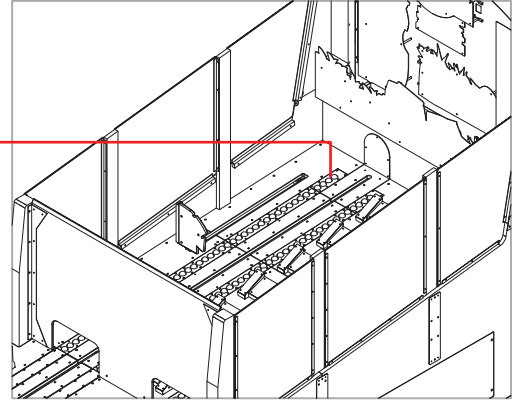

REPLACE SLOPE SENSOR EXT-IO PCB



REPLACE MAIN I/O PCB



DONE

- CODE NO.
[AJIE0PCB001]



- CODE NO.
[AJIE0PCB007]



- * General check up : Check the supply voltage and wiring connection properly
- * "NO" : Means faulty of the check up result.

4-4. SLOPE SENSOR ERROR [Er. 53]

SLOPE SENSOR

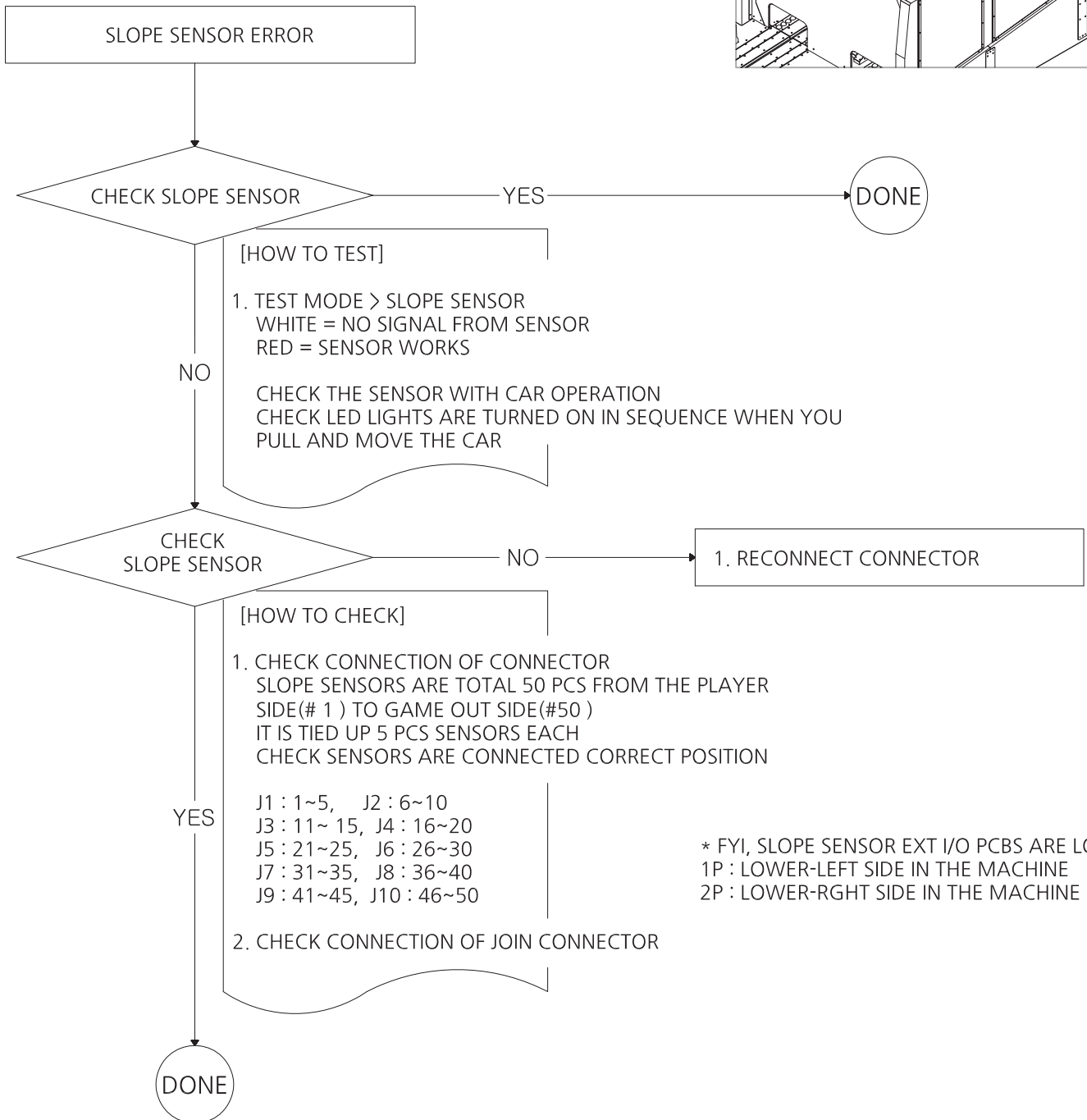
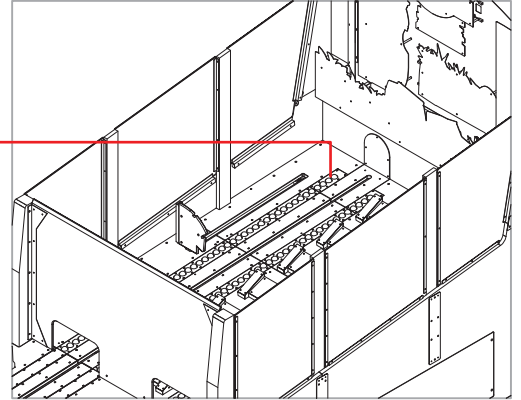

* General check up : Check the supply voltage and wiring connection properly
 * "NO" : Means faulty of the check up result.

4-5. STOPPER MOTOR ERROR [Er. 41 or Er. 42] - NO SIGNAL FROM ENCODER

IN CASE STOPPER MOTOR DOES NOT WORK

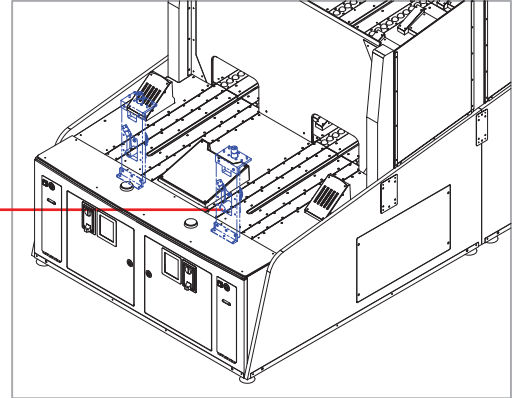

STOPPER MOTOR

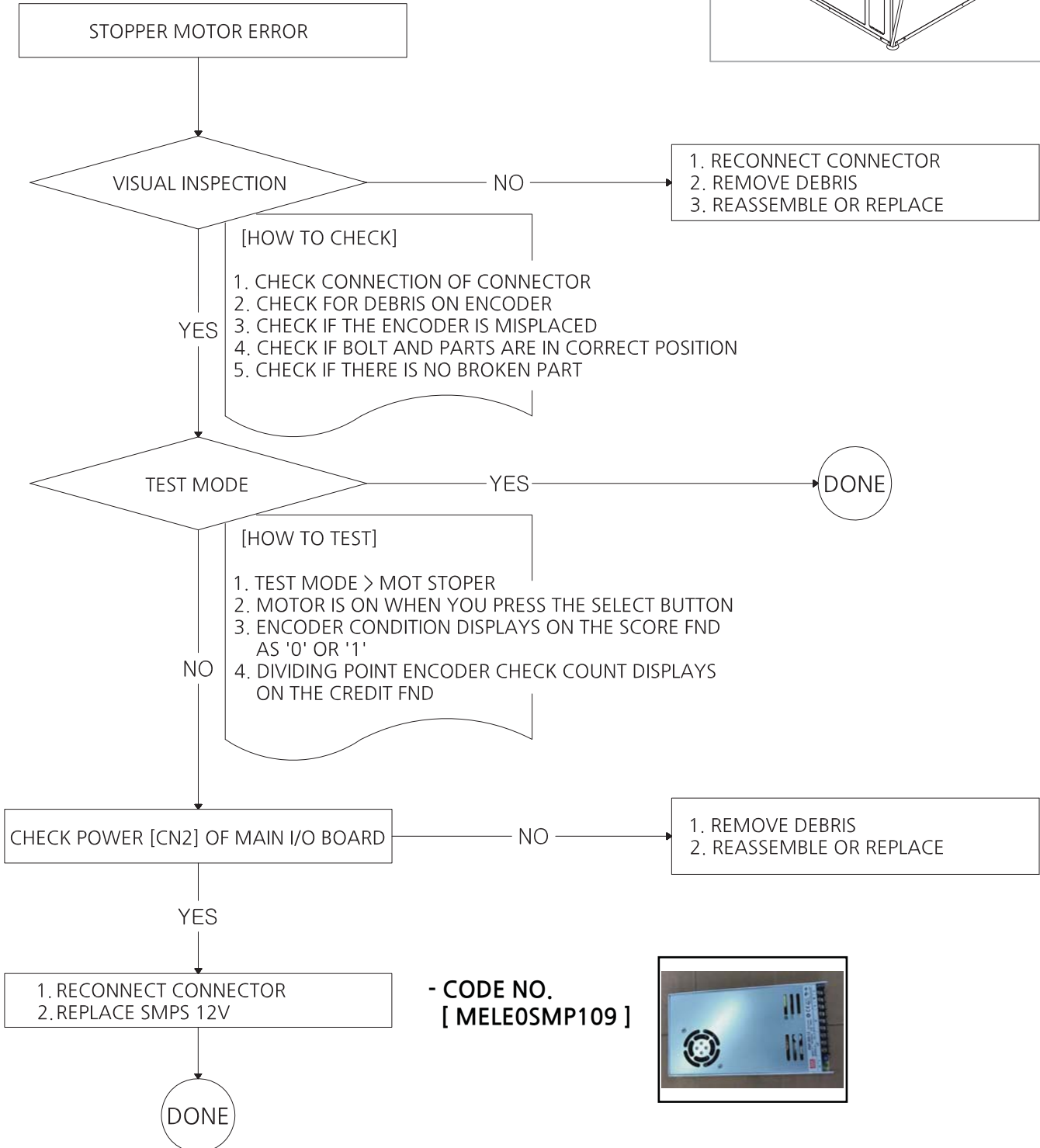

IN CASE STOPPER MOTOR NOT WORK

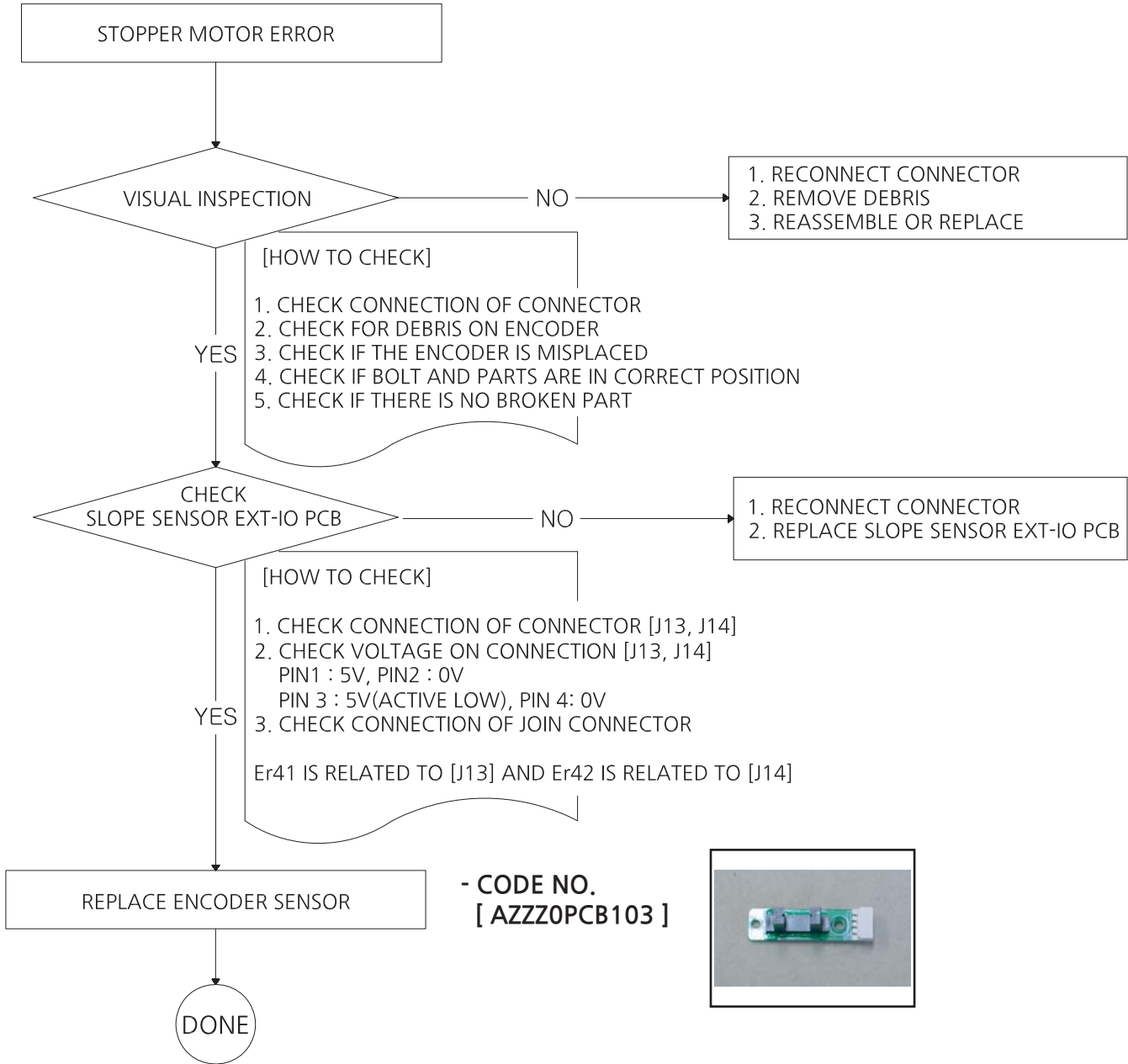

5. EXPLODED VIEW

5-1. MAIN CABINET PART

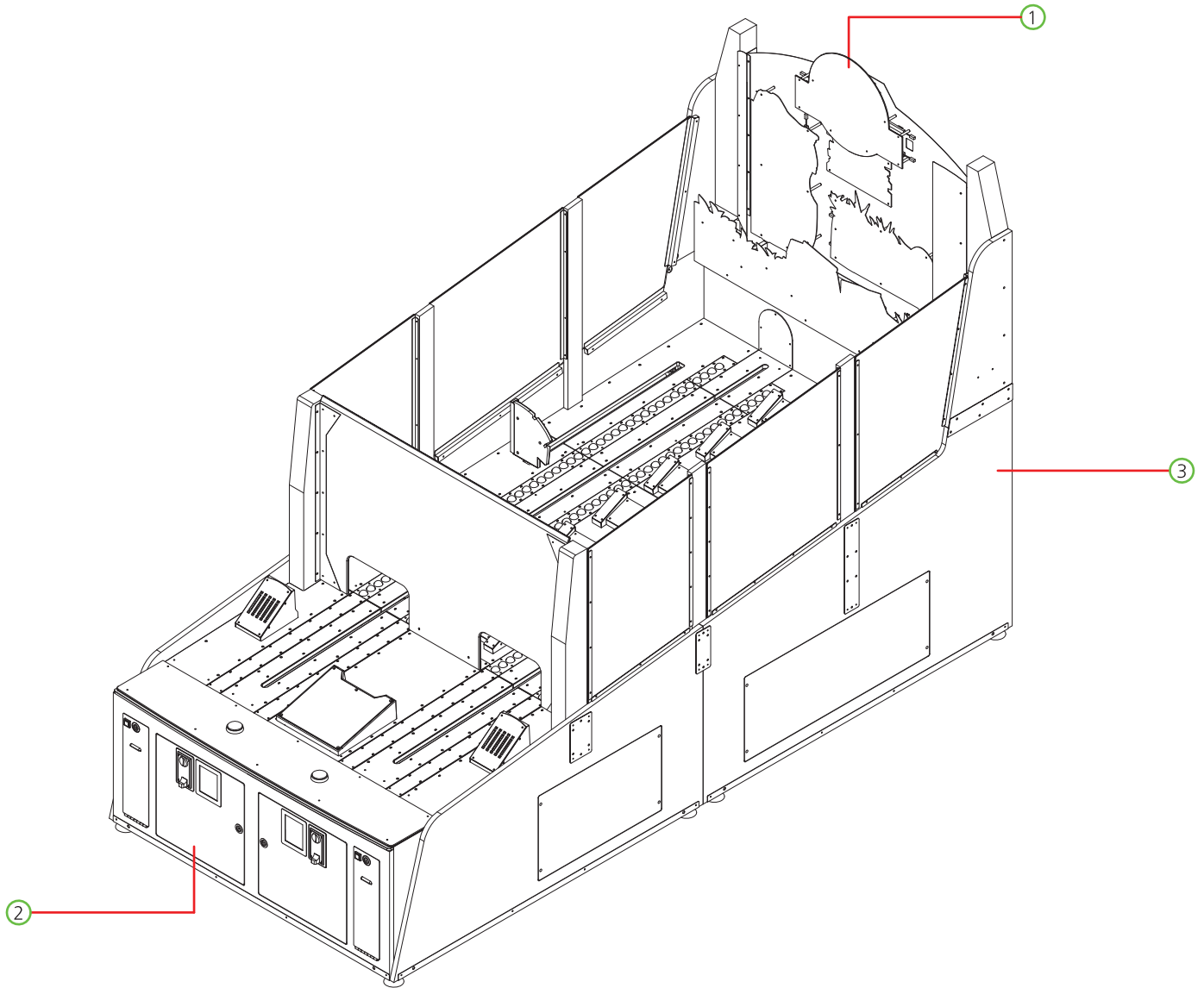

NO.	PART NAME	SPEC.	QUANTITY	CODE NO.
1	UPPER CABINET ASS'Y	-	1	-
2	FRONT CABINET ASS'Y	-	1	-
3	REAR CABINET ASS'Y	-	1	-

5-2. UPPER CABINET PART

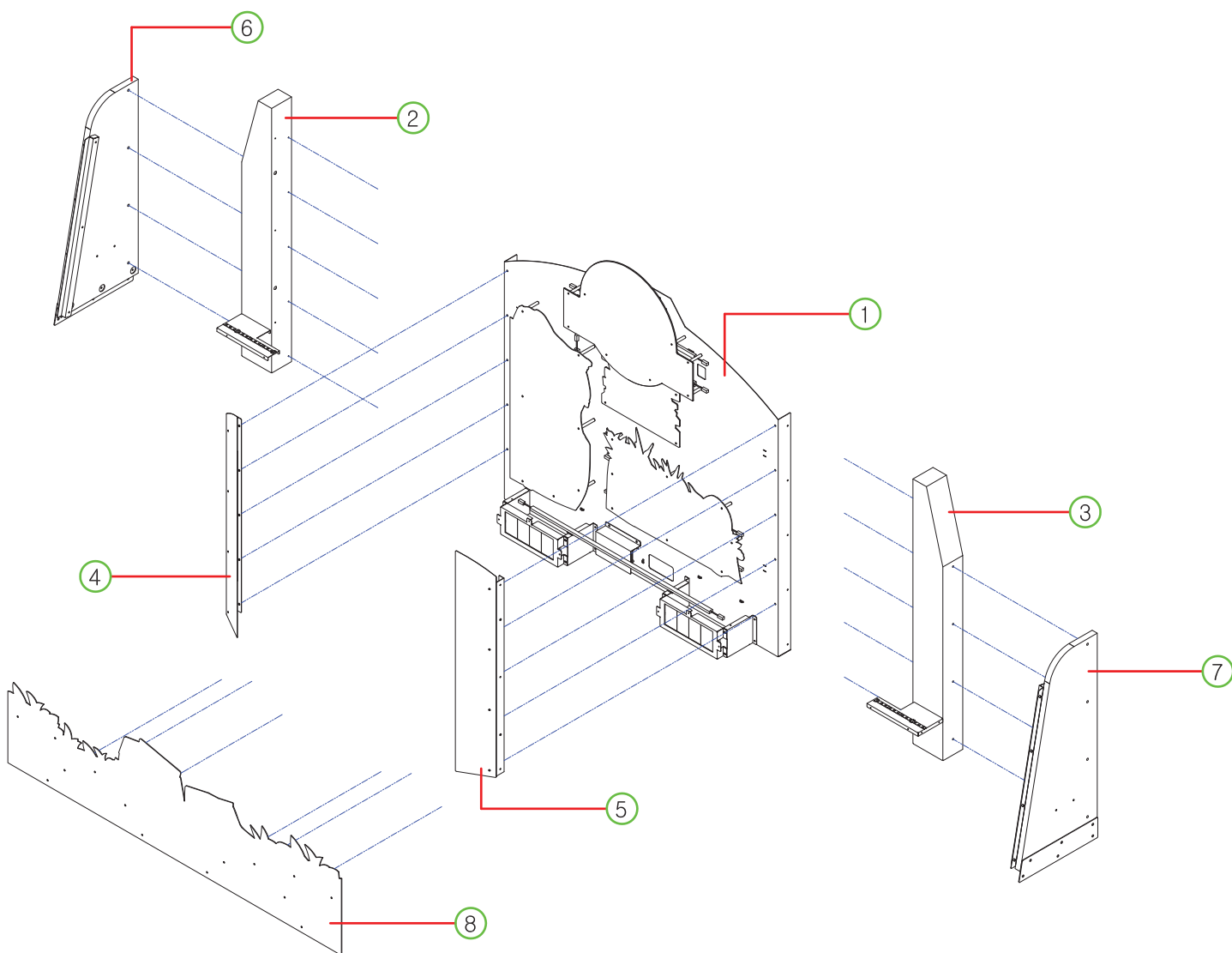

NO.	PART NAME	SPEC.	QUANTITY	CODE NO.
1	UPPER CABINET BACKGROUND PART	-	1	-
2	SIDE DECO-L PART	-	1	-
3	SIDE DECO-R PART	-	1	-
4	DOOR-L PART	-	1	-
5	DOOR-R PART	-	1	-
6	SIDE PLATE-L PART	-	1	-
7	SIDE PLATE-R PART	-	1	-
8	UPPER CABINET FOREST FND COVER ACRYL	-	1	-

(1) BACKGROUND PART

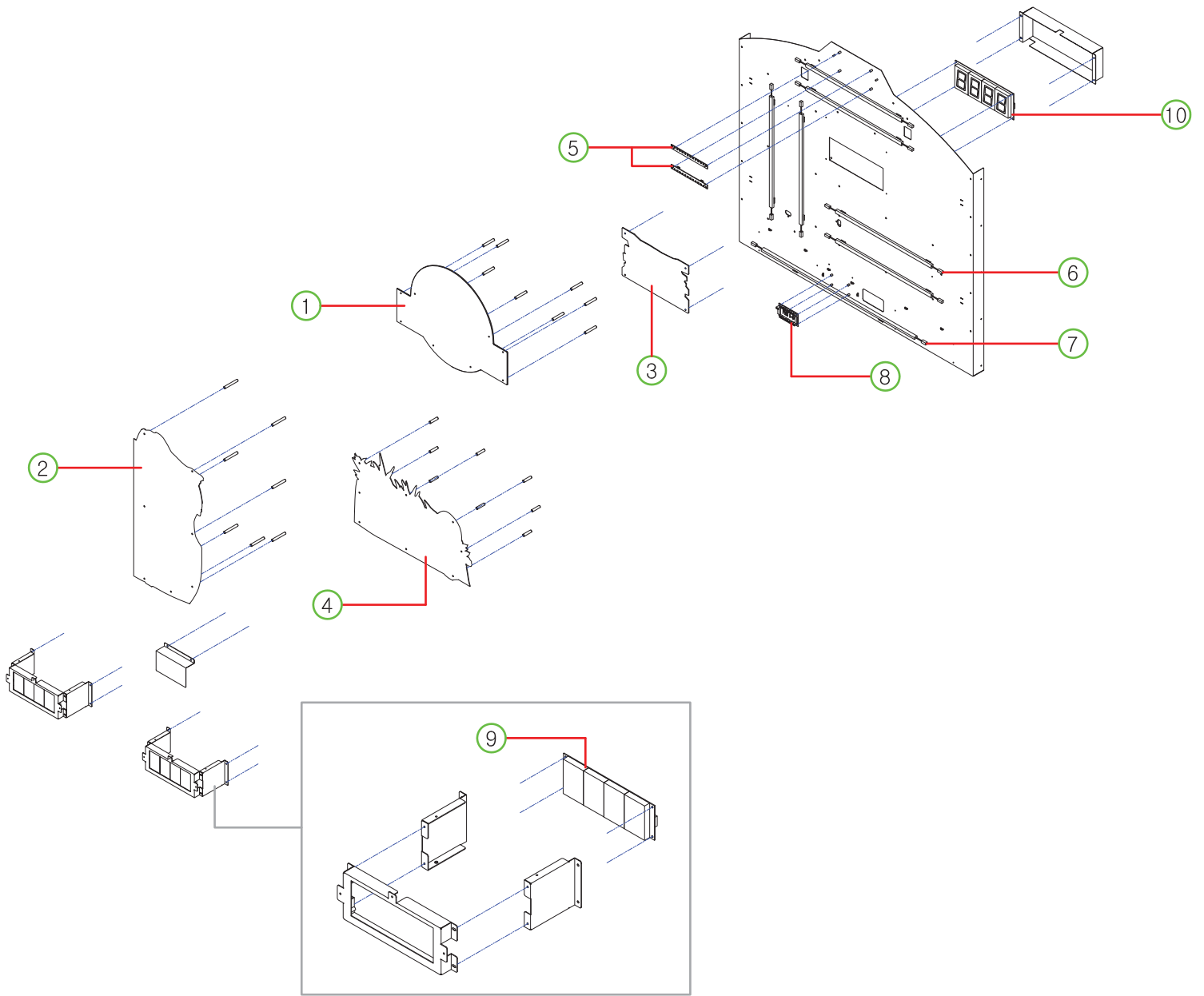

NO.	PART NAME	SPEC.	QUANTITY	CODE NO.
1	UPPER CABINET BILLBOARD ACRYL	ACRYL-2.7t	1	AJIE0ACP005
2	UPPER CABINET DINOSAUR ACRYL-A	PET-2.0t	1	AJIE0ACP006
3	UPPER CABINET BACKGROUND FND ACRYL	ACRYL-2.7t	1	AJIE0ACP004
4	UPPER CABINET DINOSAUR ACRYL-B	PET-2.0t	1	AJIE0ACP007
5	JWIE LED PCB ASS'Y	WHITE 14EA	2	AJIE0PCB006
6	LED BAR PCB ASS'Y	CW500	6	AZZZ0PCB124
7	LED BAR PCB ASS'Y	710mm	1	AZZZ0PCB165
8	FND EXT IO PCB ASS'Y	90x50 16BIT EXT	1	ABSP0PCB005
9	FND PCB ASS'Y	4870-4(STRAIGHT)	1	AFND0PCB009
10	FND PCB ASS'Y	6390-4(STRAIGHT)	1	AFND0PCB011

(2) SIDE DECO-L, R PART

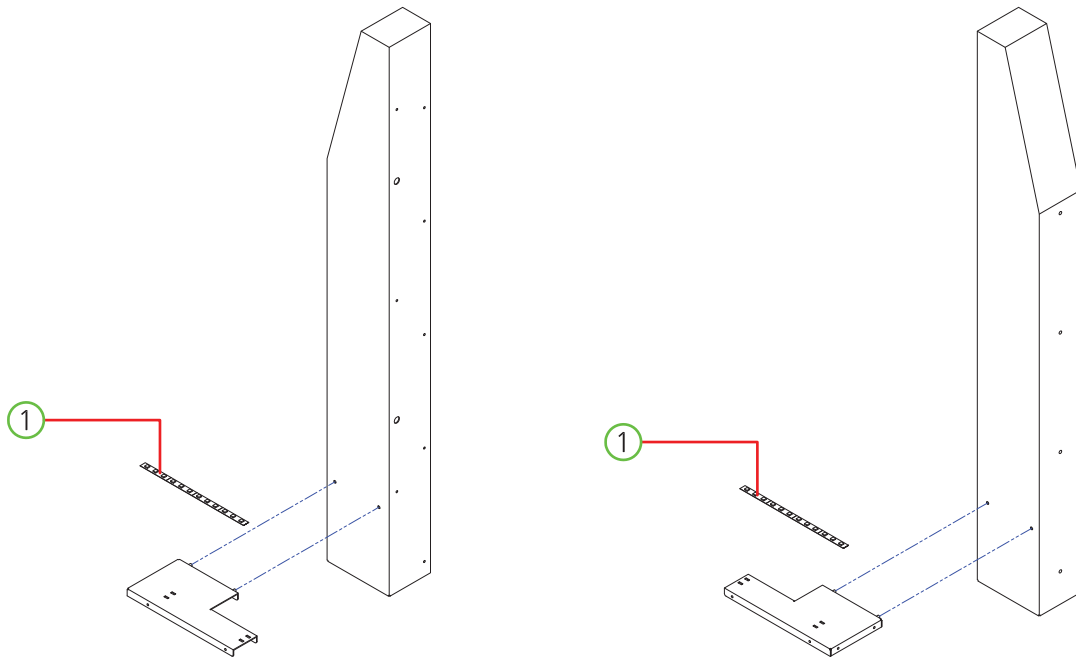

NO.	PART NAME	SPEC.	QUANTITY	CODE NO.
1	BILLBOARD RED PCB ASS'Y	FLEX_3528_RED_200	2	MELE0LED069

(3) DOOR-L, R PART

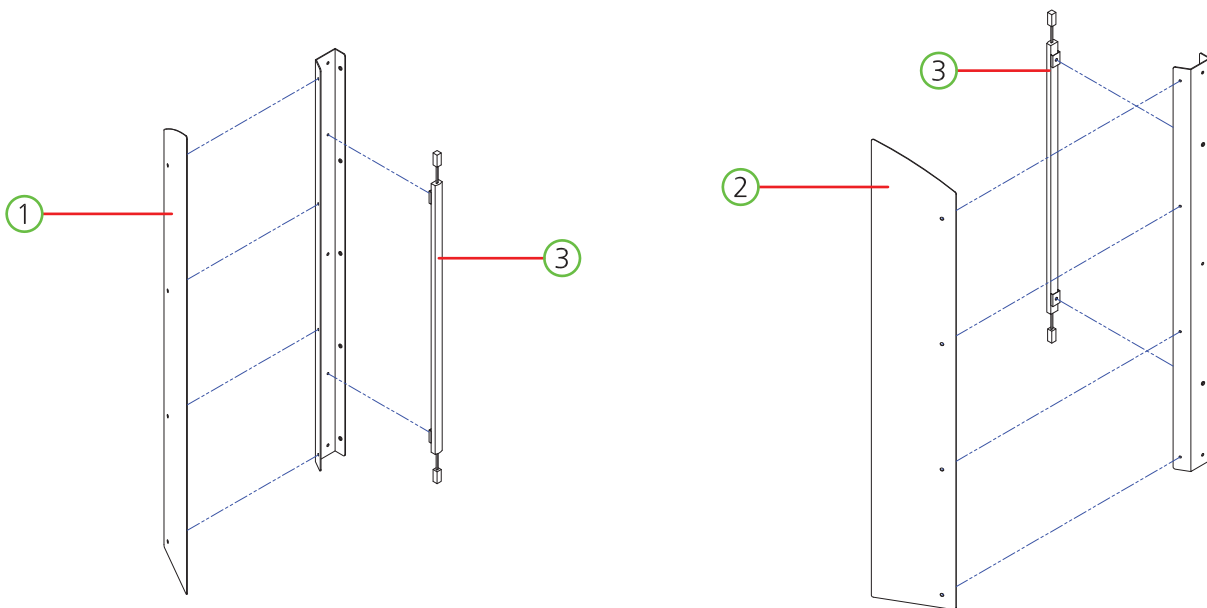

NO.	PART NAME	SPEC.	QUANTITY	CODE NO.
1	UPPER CABINET SIDE DOOR DECO ACRYL-L	PET-1.0t	1	AJIE0ACP002
2	UPPER CABINET SIDE DOOR DECO ACRYL-R	PET-1.0t	1	AJIE0ACP003
3	LED BAR PCB ASS'Y	CW500	2	AZZZ0PCB124

5-3. FRONT CABINET PART

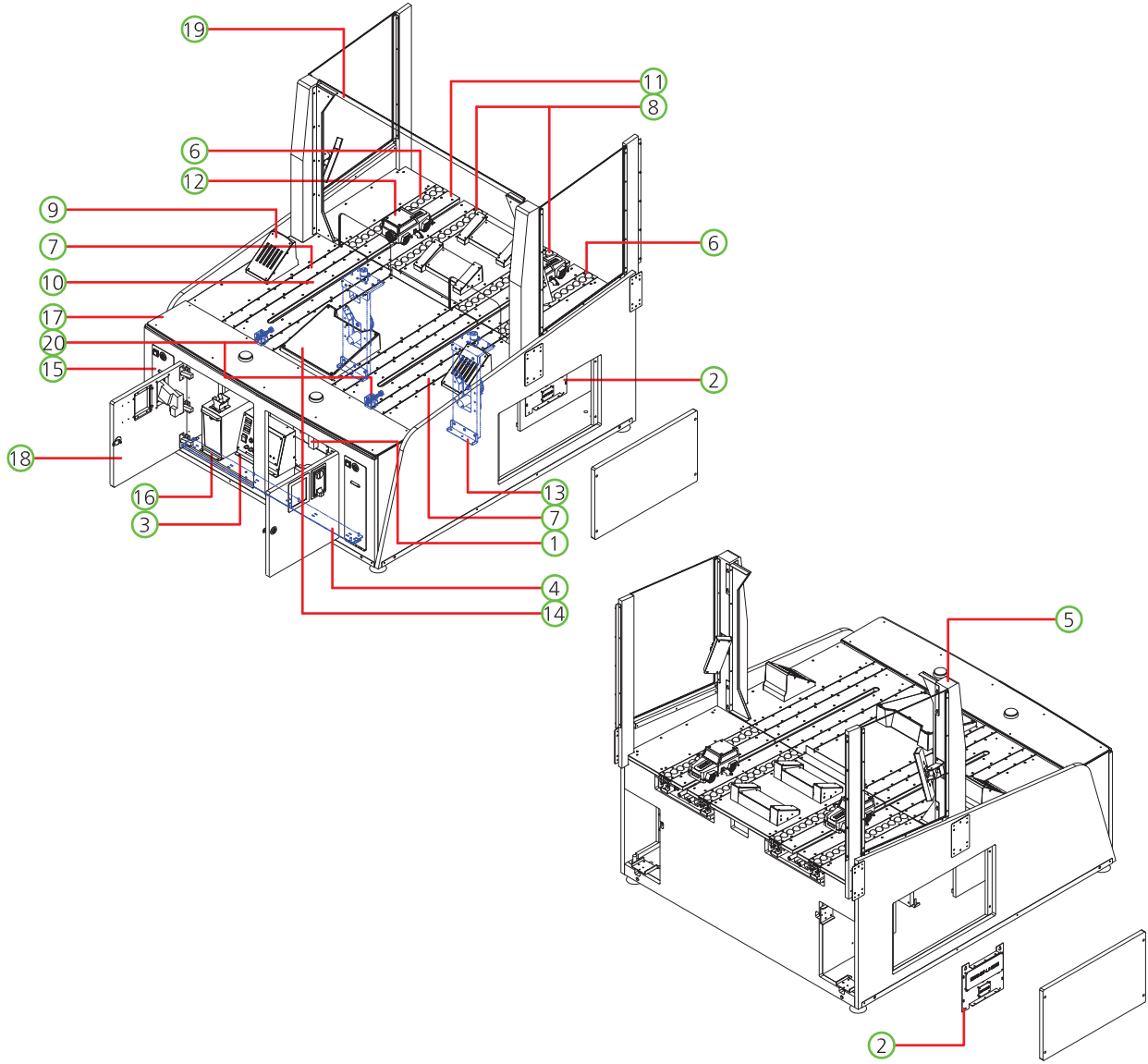

NO.	PART NAME	SPEC.	QUANTITY	CODE NO.
1	MAIN BOARD BOX PART	-	1	-
2	FRONT SIDE PCB PART	-	1	-
3	CONTROL PANEL PART	-	1	-
4	FRONT CABINET BOTTOM FLEX LED PART	-	1	-
5	FRONT DECO-L, R PART	-	2	-
6	SIDE LED SENSOR-L, R PART	-	2	-
7	SIDE GO LED-L, R PART	-	2	-
8	SIDE LED NO SENSOR-L, R PART	-	2	-
9	SPEAKER COVER PART-L, R PART	-	2	-
10	RAIL COVER FRONT-L, R PART	-	2	-
11	RAIL COVER REAR-L, R PART	-	2	-
12	CAR MOVING PART	-	2	-
13	CAR STOPPER PART	-	2	-
14	FRONT CENTER COVER PART	-	1	-
15	TICKET DOOR PART	-	2	-
16	COIN BOX PART	-	2	-
17	BUTTON PART	-	1	-
18	FRONT DOOR-L, R PART	-	2	-
19	FRONT CABINET PROTECT ACRYL PART	-	1	-
20	FRONT DAMPER PART	-	2	-

(1) MAIN BOARD BOX PART

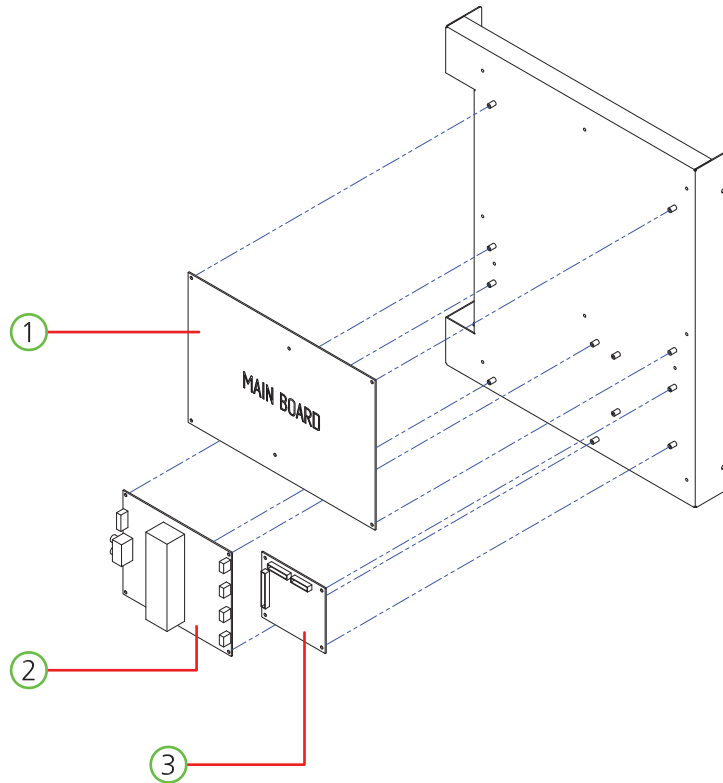

NO.	PART NAME	SPEC.	QUANTITY	CODE NO.
1	MAIN IO PCB ASS'Y	-	1	AJIEOPCB007
2	DIGITAL AMP PCB ASS'Y	2.1CH	1	APUJ0PCB002
3	WS2812B IO PCB ASS'Y	-	1	AZZZ0PCB185

(2) FRONT SIDE PCB PART

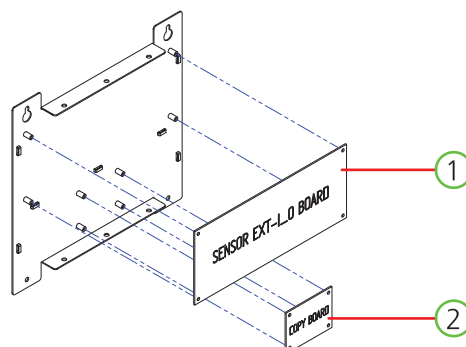

NO.	PART NAME	SPEC.	QUANTITY	CODE NO.
1	SLOPE SENSOR EXT IO PCB ASS'Y	64 PORT	1	AJIEOPCB001
2	DISPLAY COPY PCB ASS'Y	-	1	AGST0PCB008

(3) CONTROL PANEL PART

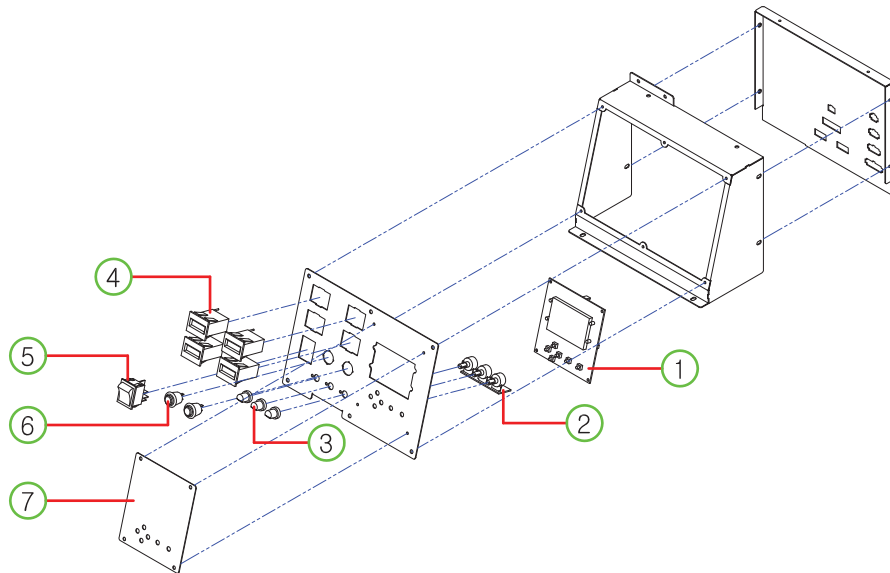

NO.	PART NAME	SPEC.	QUANTITY	CODE NO.
1	SETUP LCD PCB ASS'Y	-	1	AZZZ0PCB113
2	VOLUME PCB ASS'Y	3CH	1	APUJ0PCB005
3	VOLUME KNOB	CAP BLUE	3	MELE0VOL007
4	COUNTER	OA127CL	4	MZZZ0COU002
5	ROCKER SWITCH	T-125 4P	1	MELE0SWI004
6	PUSH BUTTON SWITCH	DS 412R	2	MELE0PUS006
7	CONTROL PANEL COVER ACRYL	PET-1.0t	1	AJIE0ACP034

(4) FRONT CABINET BOTTOM FLEX LED PART

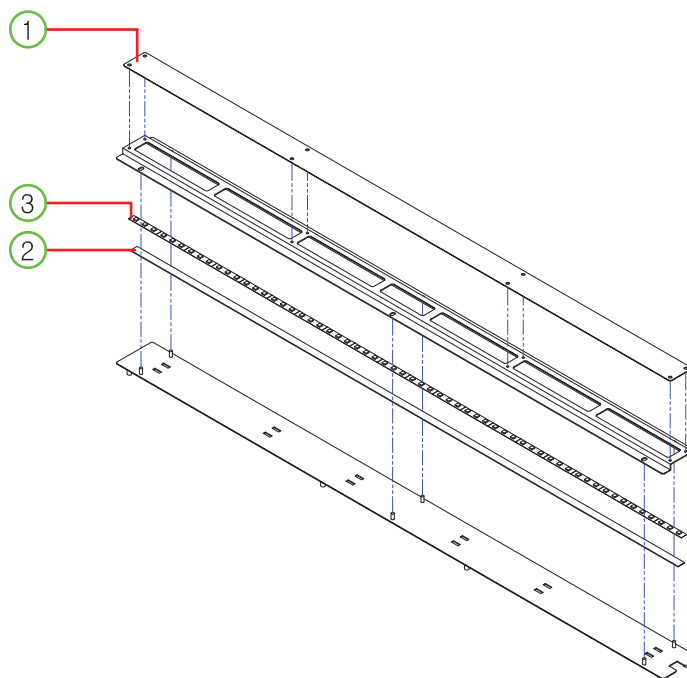

NO.	PART NAME	SPEC.	QUANTITY	CODE NO.
1	FRONT BOTTOM LED COVER PET	PET-1.0t	1	MJIE0ACR010
2	CABINET BOTTOM LED PET	PET-1.0t	1	MJIE0ACR004
3	CABINET BOTTOM FLEXIBLE LED PCB ASS'Y	FLEX_3528_RED_1000_NWP_L	1	MELE0LED070

(5) FRONT DECO-L, R PART

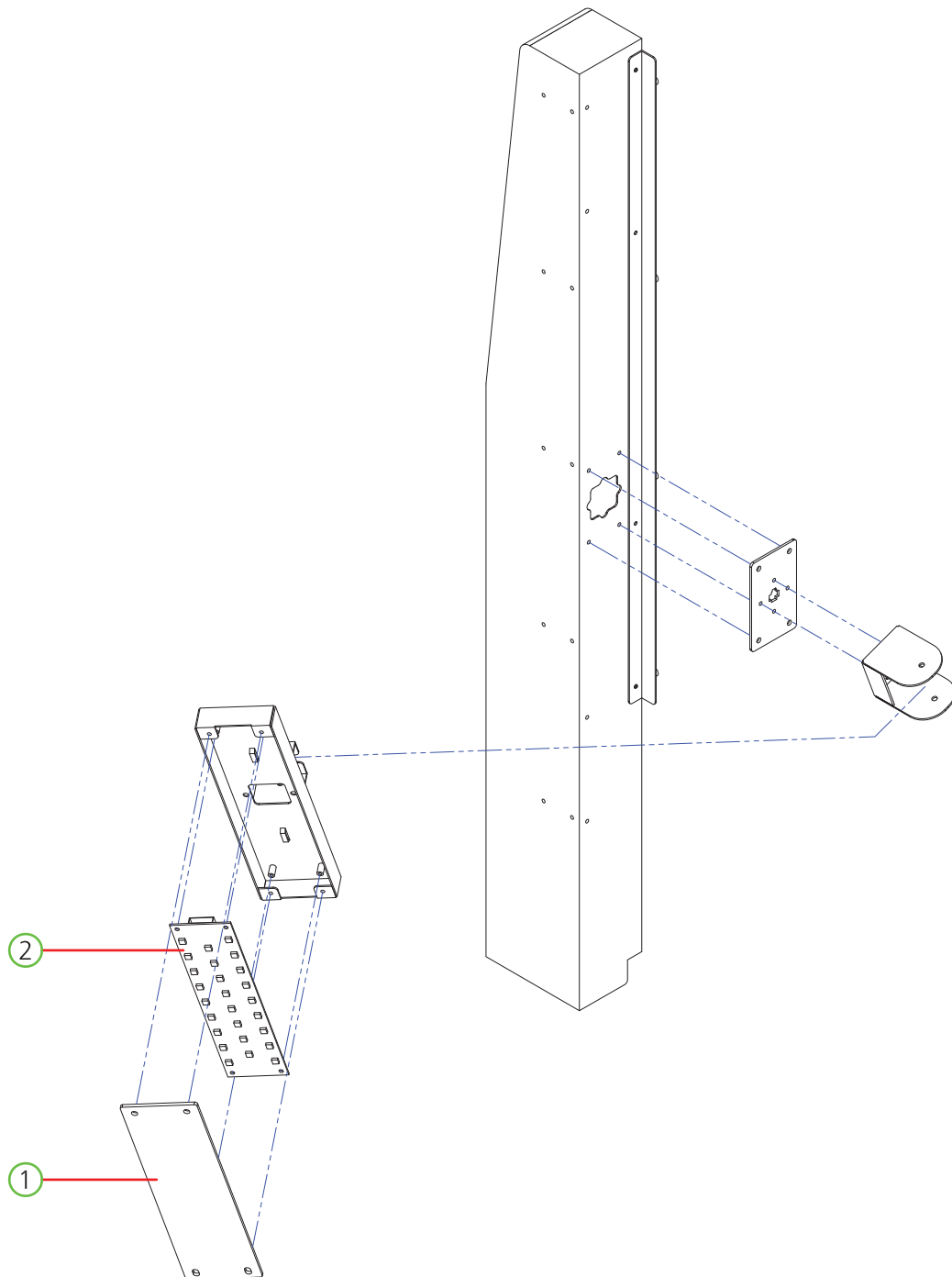

NO.	PART NAME	SPEC.	QUANTITY	CODE NO.
1	CAR POINT LIGHT COVER ACRYL	ACRYL-2.7t	1	MJIE0ACR007
2	SPOT LED PCB ASS'Y	WHITE	1	ABAP0PCB008

(6) SIDE LED SENSOR-L, R PART

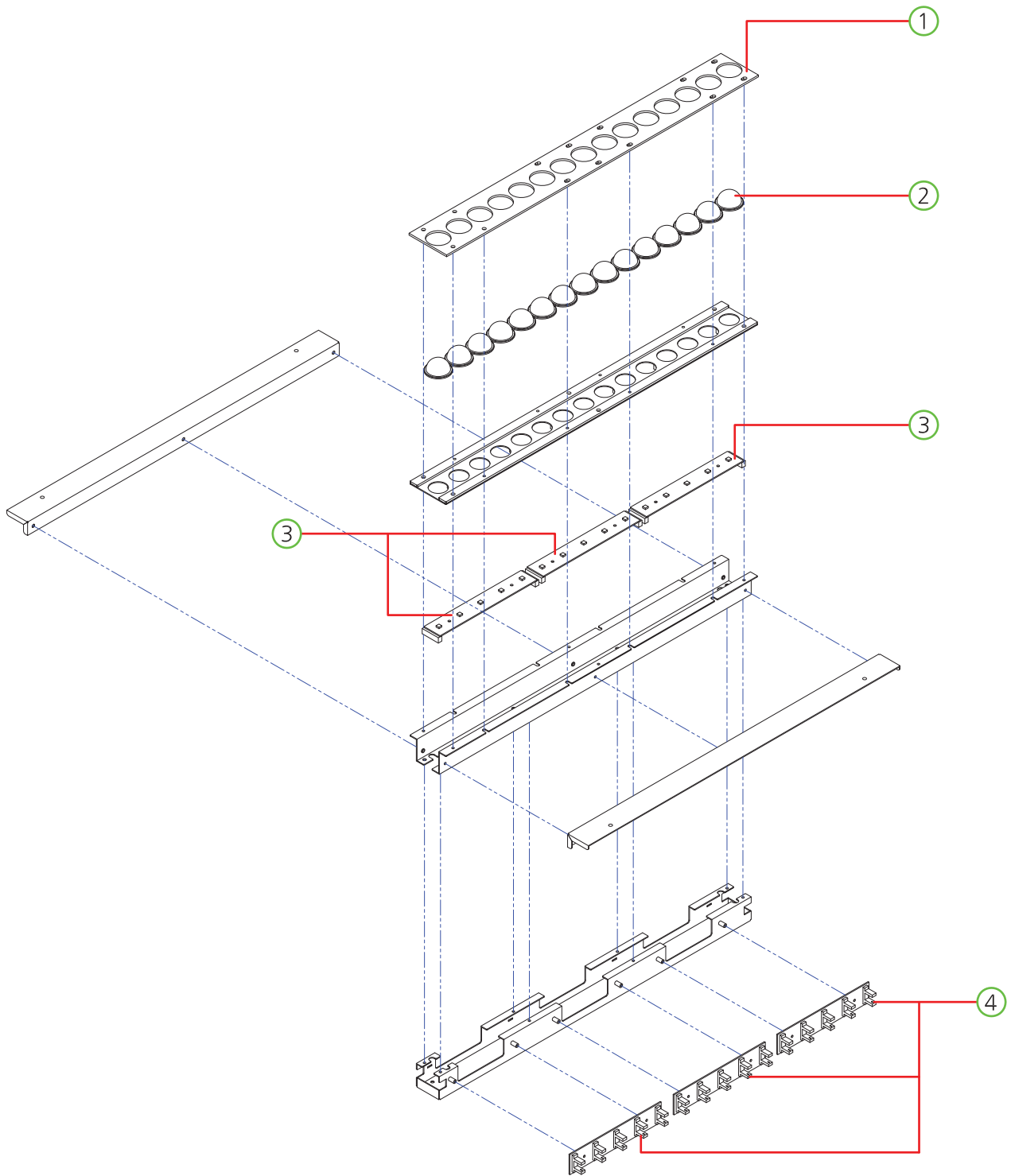

NO.	PART NAME	SPEC.	QUANTITY	CODE NO.
1	FRONT RAIL DOME COVER ACRYL	ACRYL-2.7t	1	MJIE0ACR022
2	DOME ACRYL CAP	φ30	15	MJIE0PLA001
3	SIDE LED PCB ASS'Y	RGB 5EA	3	AJIE0PCB003
4	SLOPE SENSOR (INT1x5) PCB ASS'Y	-	3	AJIE0PCB002

(7) SIDE GO LED-L, R PART

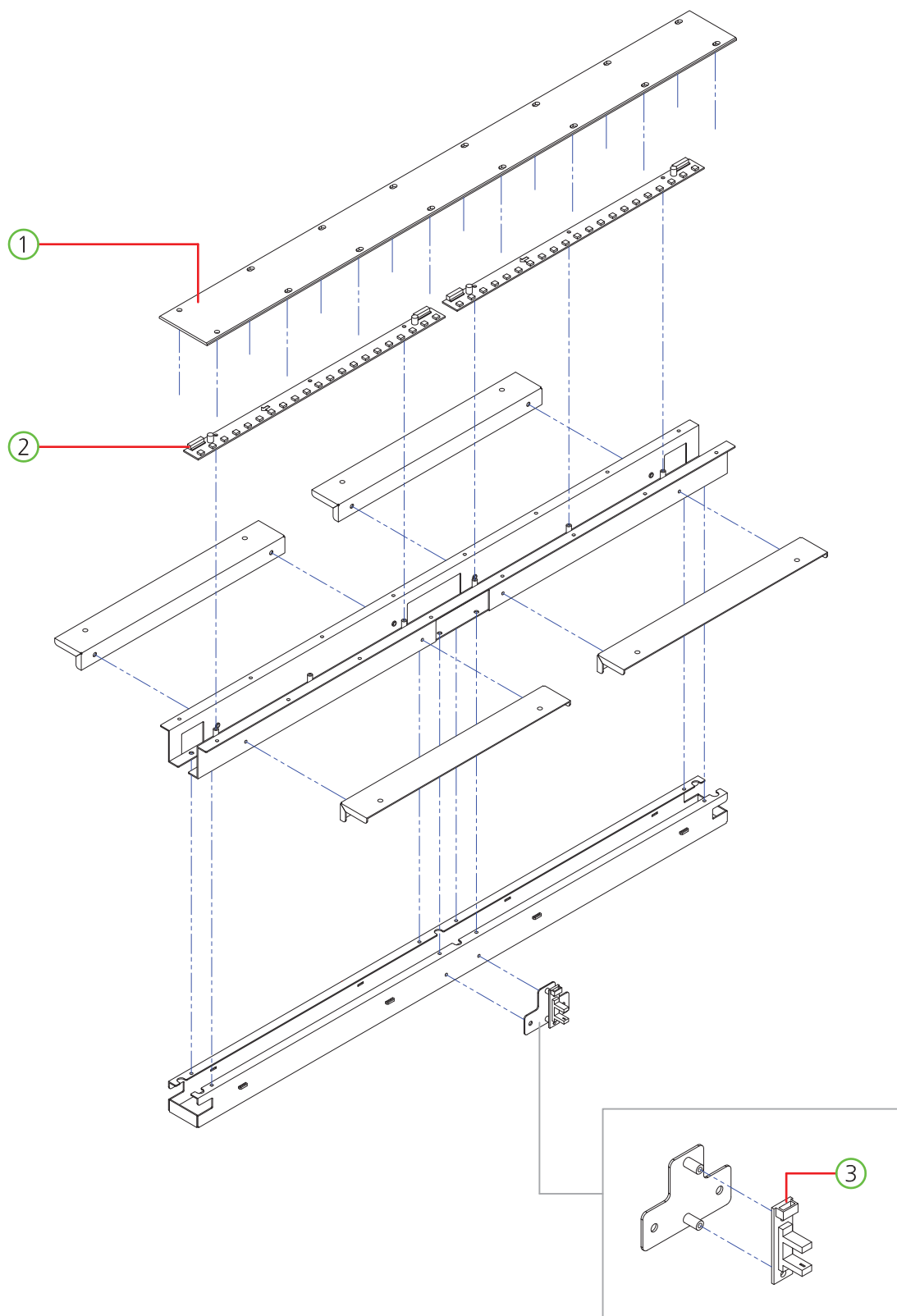

NO.	PART NAME	SPEC.	QUANTITY	CODE NO.
1	GO COVER ACRYL	ACRYL-2.7t	1	AJIE0ACP027
2	WS2813B LED PCB 21EA-R ASS'Y	21EA-R	2	APLX0PCB008
3	PHOTO INT-1 PCB ASS'Y	-	1	AZZZ0PCB103

(8) SIDE LED NO SENSOR-L, R PART

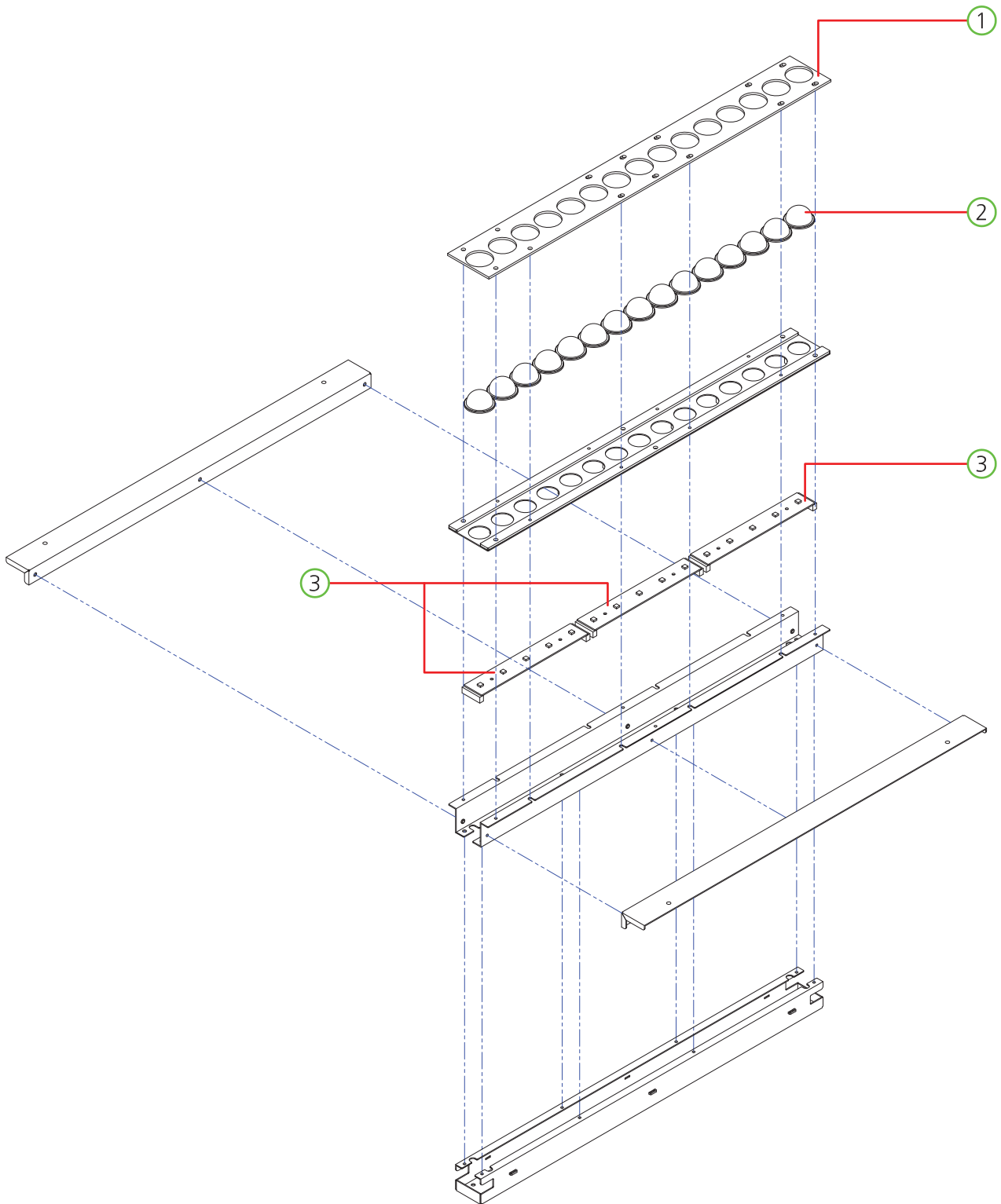

NO.	PART NAME	SPEC.	QUANTITY	CODE NO.
1	FRONT RAIL DOME COVER ACRYL	ACRYL-2.7t	1	MJIE0ACR022
2	DOME ACRYL CAP	φ30	15	MJIE0PLA001
3	SIDE LED PCB ASS'Y	RGB 5EA	3	AJIE0PCB003

(9) SPEAKER COVER PART-L, R PART

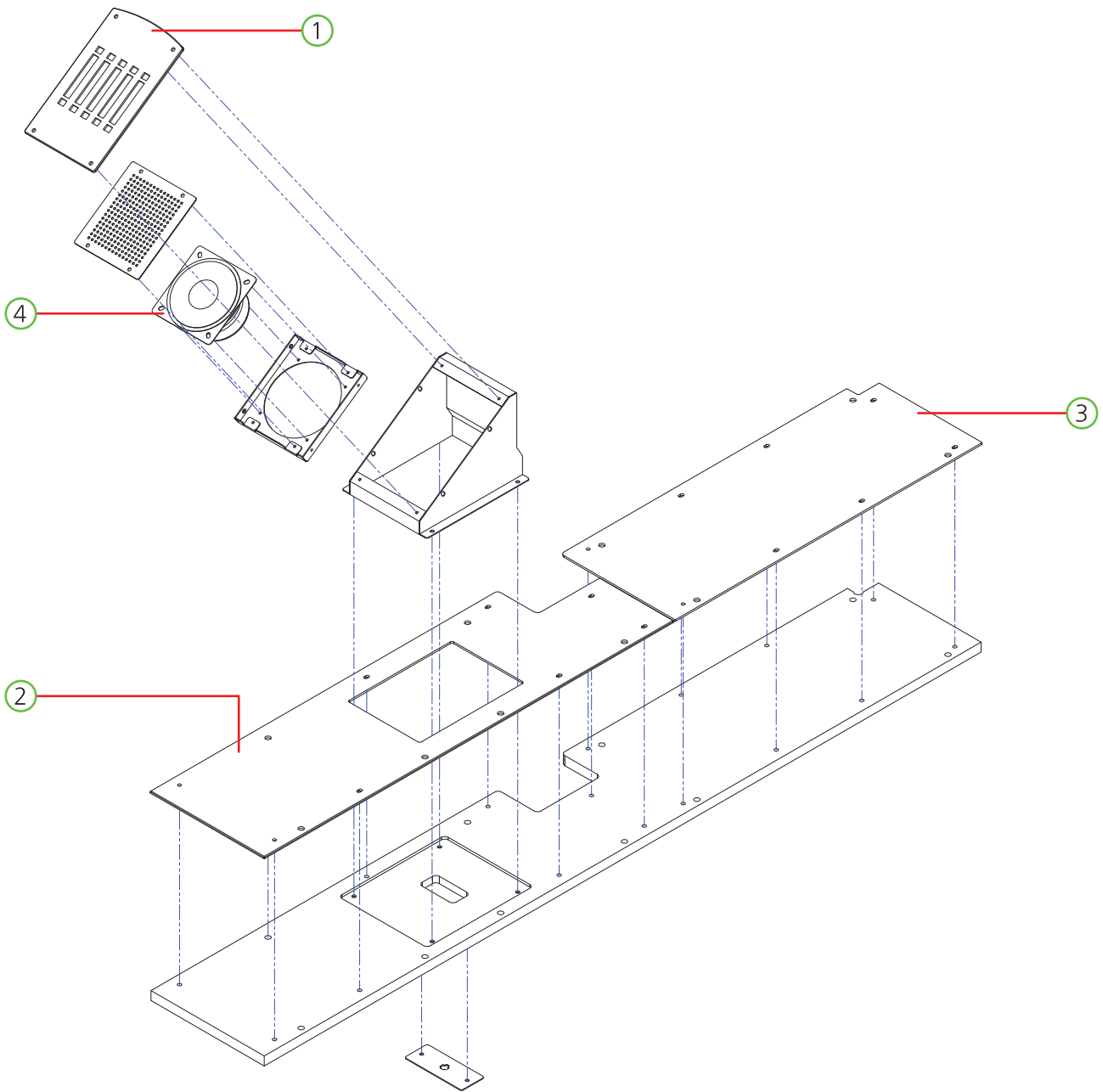

NO.	PART NAME	SPEC.	QUANTITY	CODE NO.
1	FRONT CABINET SPEAKER COVER ACRYL	ACRYL-2.7t	1	AJIE0ACP028
2	FRONT CABINET SPEAKER COVER FRONT ACRYL-L	ACRYL-2.7t	1	AJIE0ACP009
3	FRONT CABINET SPEAKER COVER REAR ACRYL-L	ACRYL-2.7t	1	AJIE0PCB003
4	SPEAKER	MID4"+TW1/2" 8OHM	1	MZZZ0SPE021

(10) RAIL COVER FRONT-L, R PART

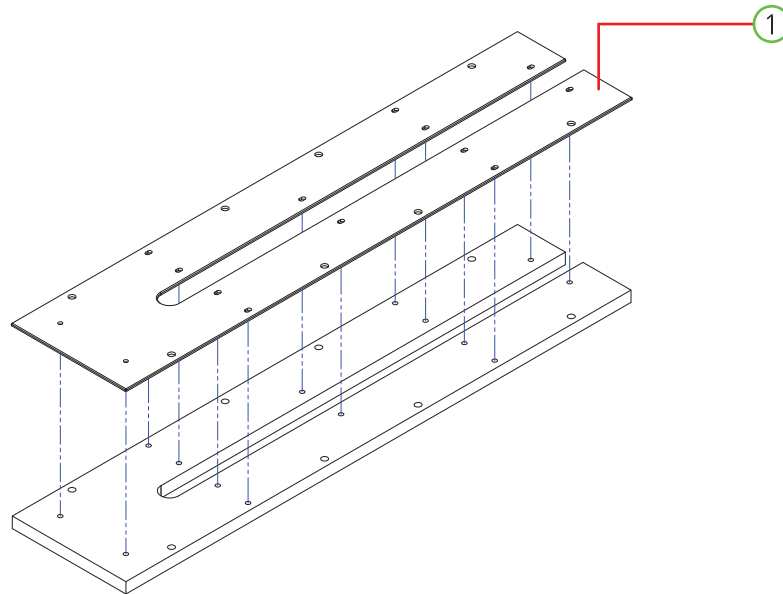

NO.	PART NAME	SPEC.	QUANTITY	CODE NO.
1	FRONT CABINET RAIL COVER FRONT ACRYL	ACRYL-2.7t	1	AJIE0ACP024

(11) RAIL COVER REAR-L, R PART

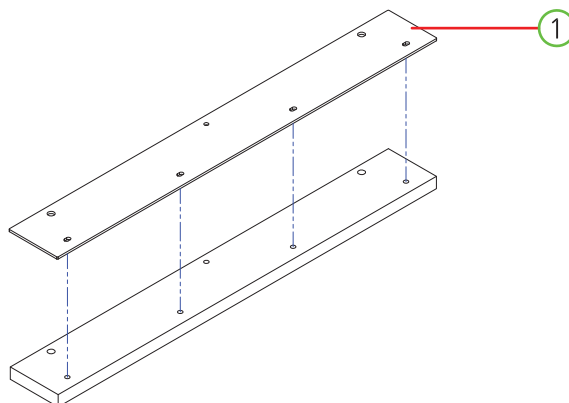

NO.	PART NAME	SPEC.	QUANTITY	CODE NO.
1	CABINET RAIL COVER ACRYL	ACRYL-2.7t	1	AJIE0ACP016

(12) CAR MOVING PART

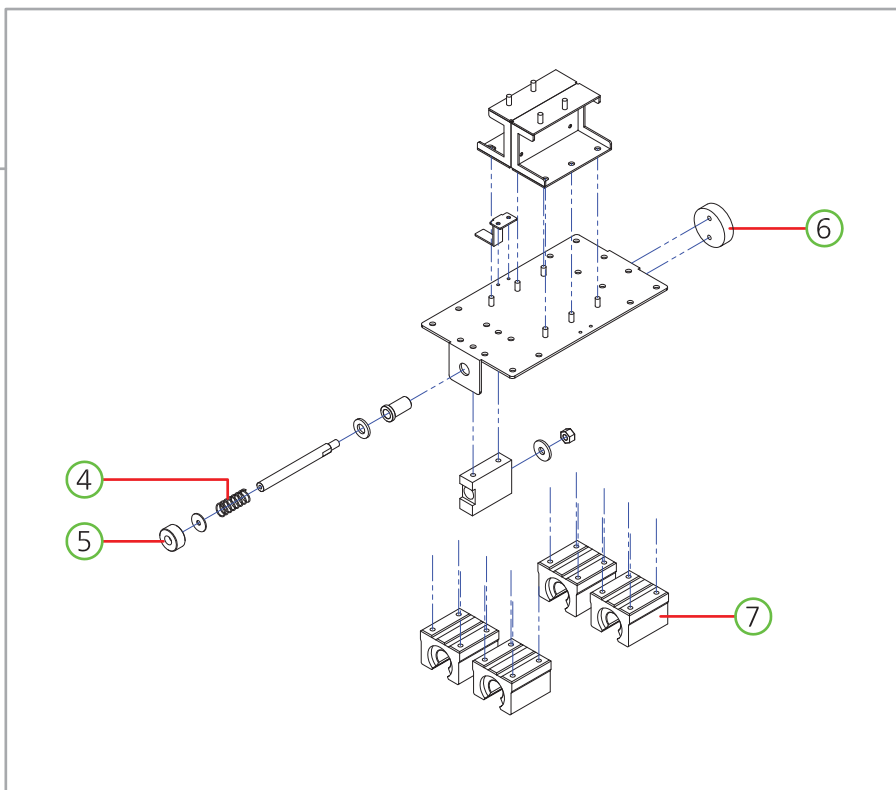
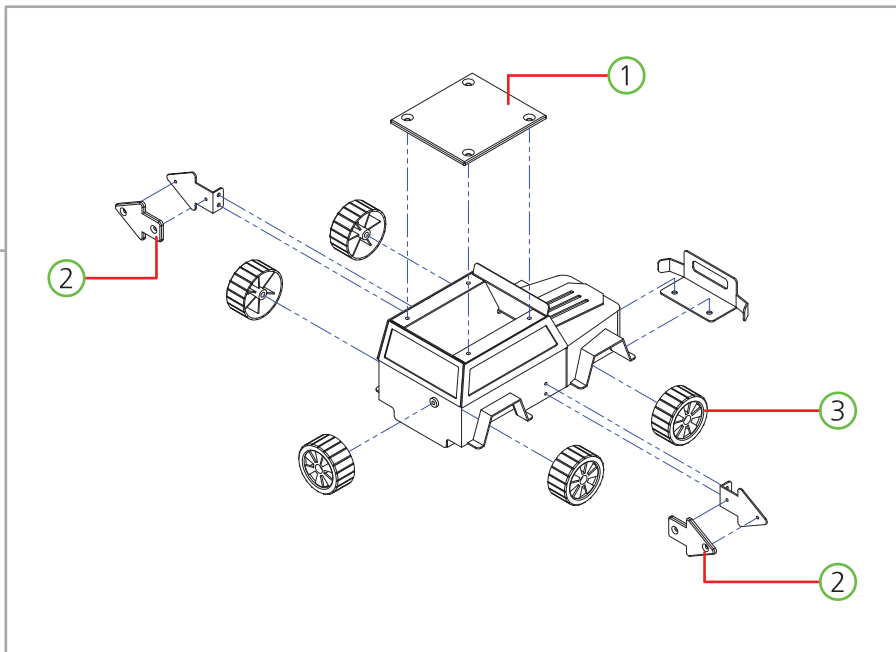
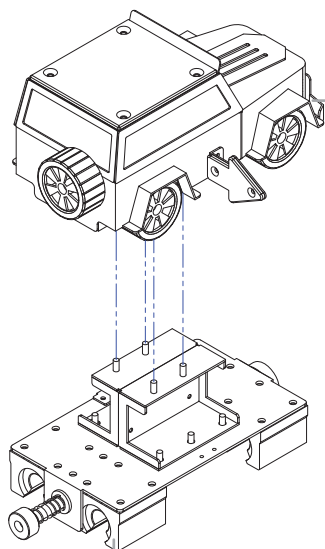

NO.	PART NAME	SPEC.	QUANTITY	CODE NO.
1	CAR TOP COVER ACRYL	ACRYL-3t	1	AJIE0ACP030
2	CAR ARROW ACRYL	ACRYL-3t	2	MJIE0ACR006
3	WHEEL	ABS / BLACK	5	MJIE0PLA002
4	CAR MOVING STOPPER TENSION SPRING	0.8t	1	MJIE0SPR001
5	DAMPER URETAN	URETHAN	1	MJIE0PRO009
6	CAR SUPPORT DAMPER URETHAN	URETHAN	1	MJIE0PRO024
7	LM BEARING UNIT	SHO 16UU	4	MZZZ0BEA135

(13) CAR STOPPER PART

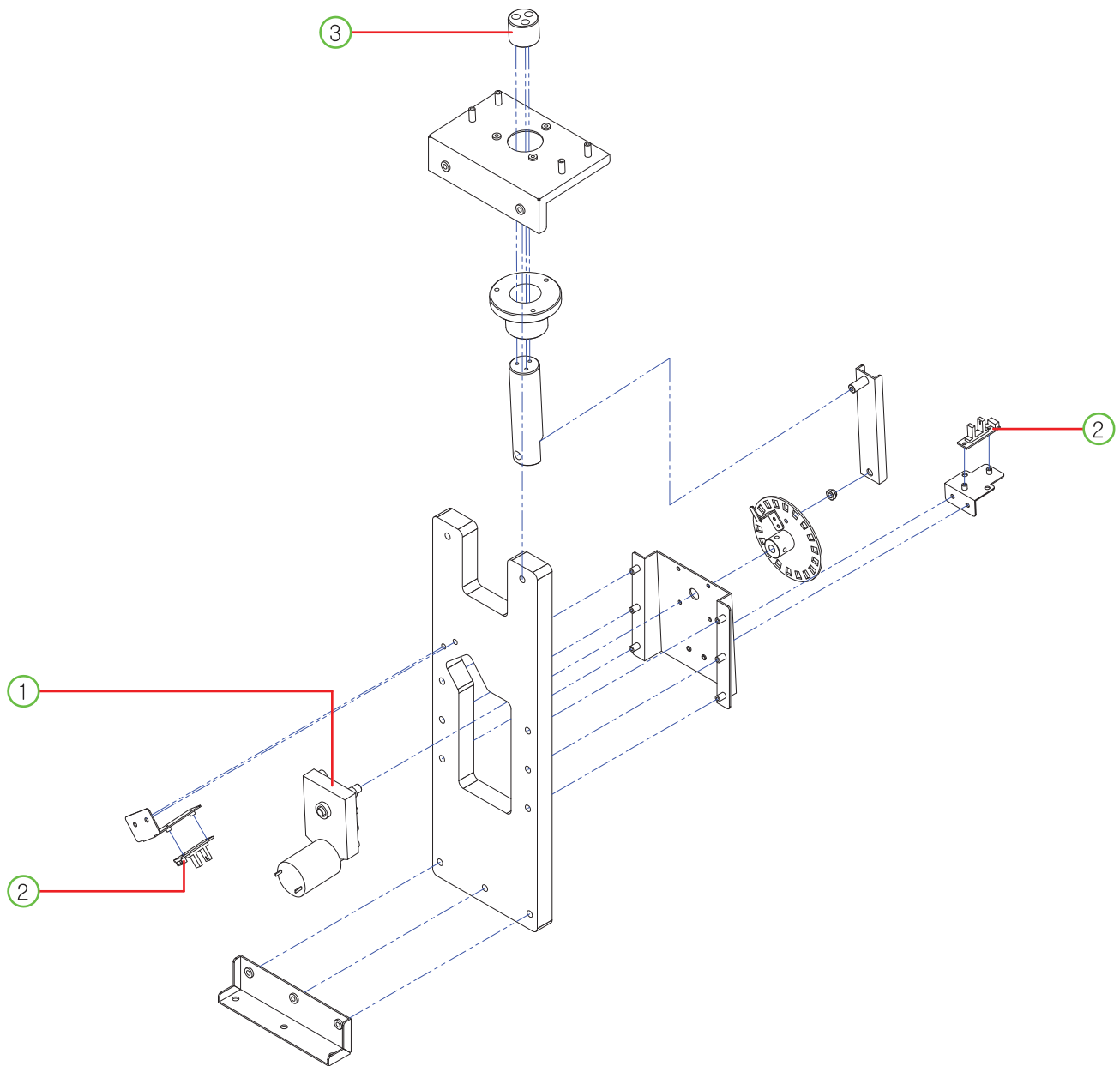

NO.	PART NAME	SPEC.	QUANTITY	CODE NO.
1	MOTOR	KGE-3448S1, 62:1	1	MZZ0MOT157
2	PHOTO-INT1_ANGLE PCB ASS'Y	-	2	AZZ0PCB103
3	CAR STOPPER SHAFT DAMPER URETHAN	URETHAN	1	MJIE0PRO007

(14) FRONT CENTER COVER PART

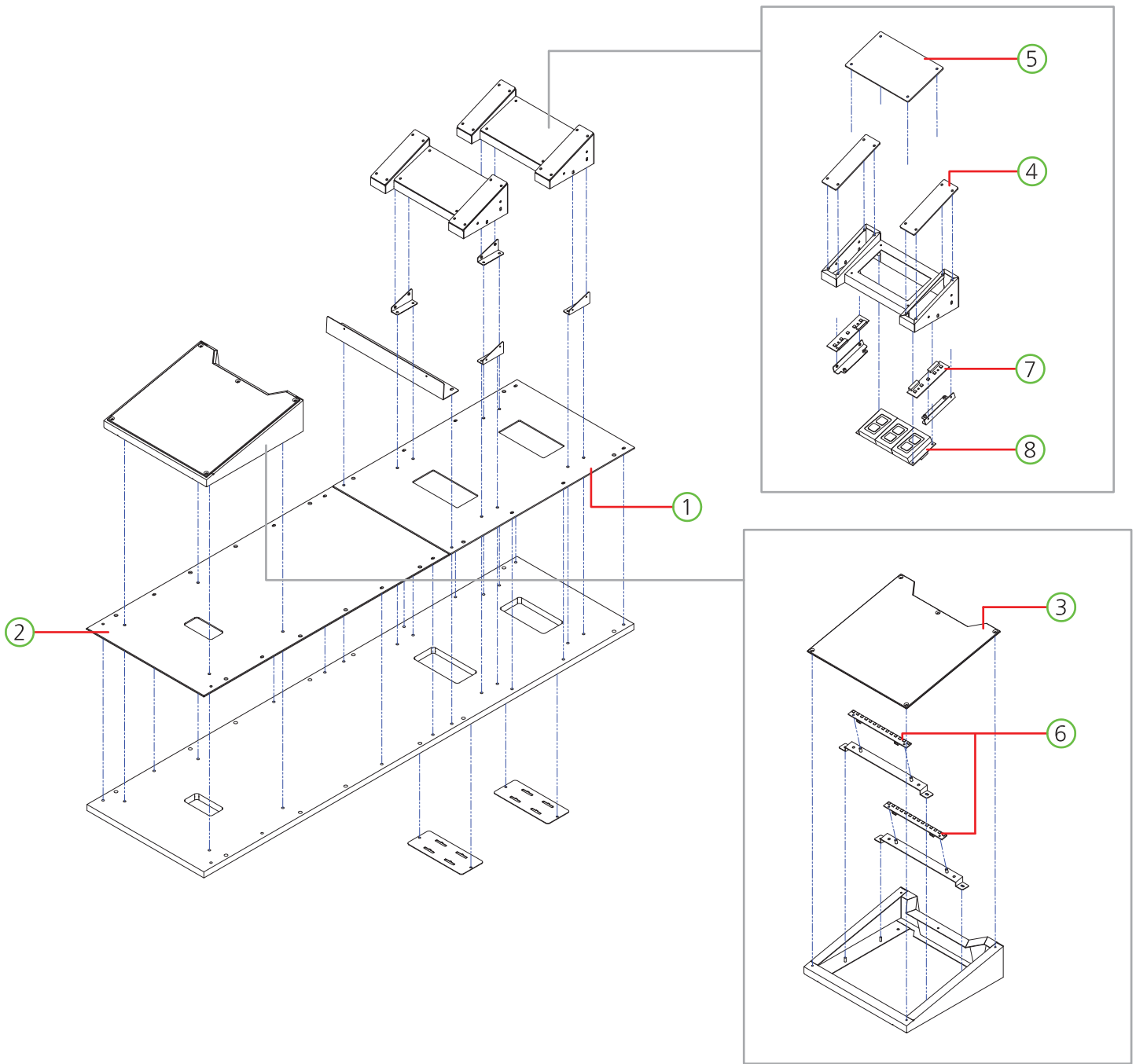

NO.	PART NAME	SPEC.	QUANTITY	CODE NO.
1	FRONT CABINET CENTER COVER FRONT ACRYL	ACRYL-2.7t	1	AJIE0ACP026
2	FRONT CABINET CENTER COVER REAR ACRYL	ACRYL-2.7t	1	AJIE0ACP025
3	HOW TO PLAY ACRYL	ACRYL-3t	1	AJIE0ACP032
4	SCORE FND SIDE COVER ACRYL	ACRYL-2.7t	4	MJIE0ACR037
5	SCORE FND COVER ACRYL	ACRYL-2.7t	2	AJIE0ACP029
6	JWIE LED PCB ASS'Y	WHITE 14EA	2	AJIE0PCB006
7	SCORE LED PCB ASS'Y	RGB 5EA	4	AJIE0PCB004
8	FND PCB ASS'Y	4870-3(STRAIGHT)	2	AFND0PCB027

(15) TICKET DOOR PART

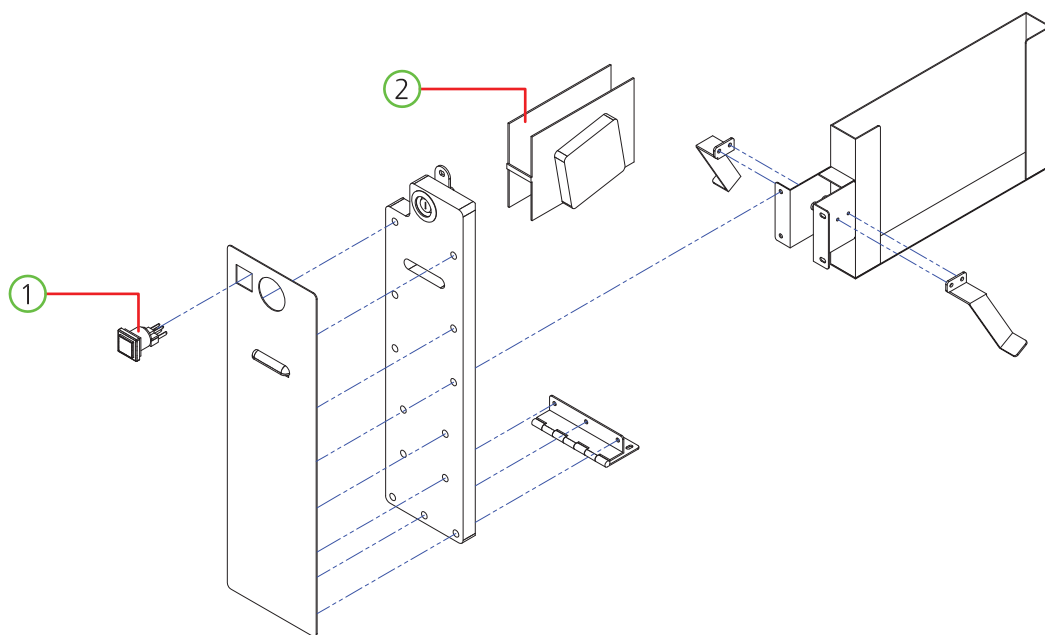

NO.	PART NAME	SPEC.	QUANTITY	CODE NO.
1	TICKET BUTTON SWITCH	AMIPB-26HS-R12D	1	MMUM0BUT002
2	TICKET DISPENSER	CLE CL-002Q_270	1	MZZZ0TID010

(16) COIN BOX PART

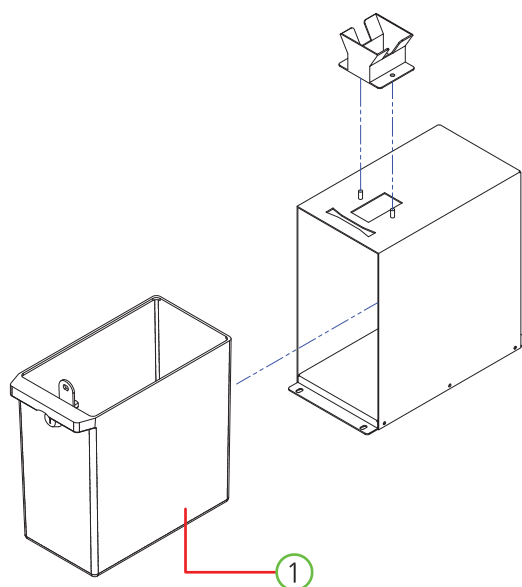

NO.	PART NAME	SPEC.	QUANTITY	CODE NO.
1	COIN BOX ASS'Y_WITH 6001	SMALL_200*198*107	1	AZZZ0ASS002

(17) BUTTON PART

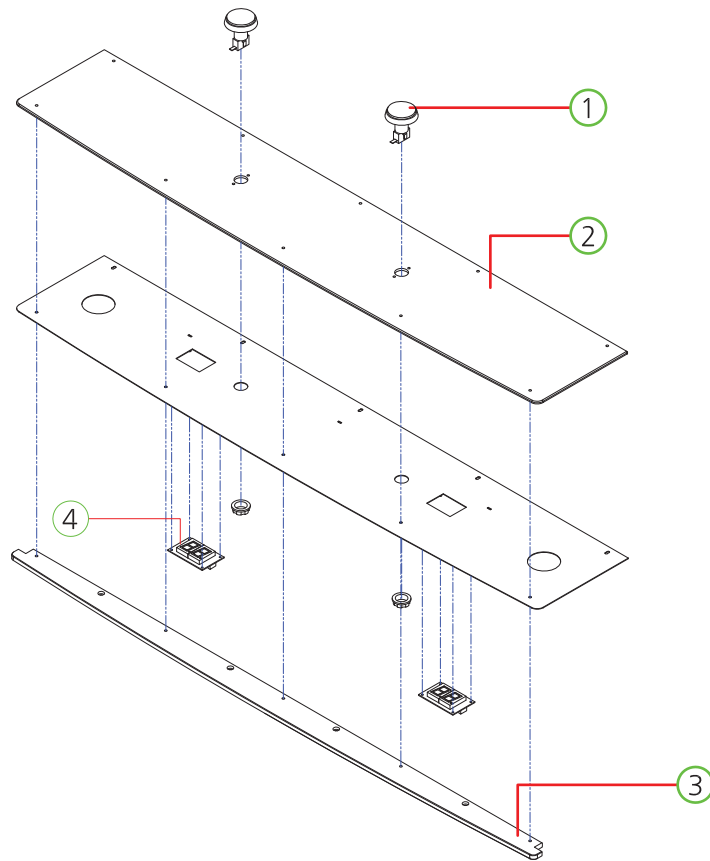

NO.	PART NAME	SPEC.	QUANTITY	CODE NO.
1	BUTTON SWITCH	AMIPB-60HR-W12D	1	MZZZ0BUT054
2	BUTTON COVER ACRYL	ACRYL-4.5t	1	MJIE0ACR003
3	FRONT BUTTON ACRYL	ACRYL-10t	1	MJIE0ACR011
4	FND PCB ASS'Y	2941-2(STRAIGHT)	2	AFND0PCB003

(18) FRONT DOOR-L, R PART

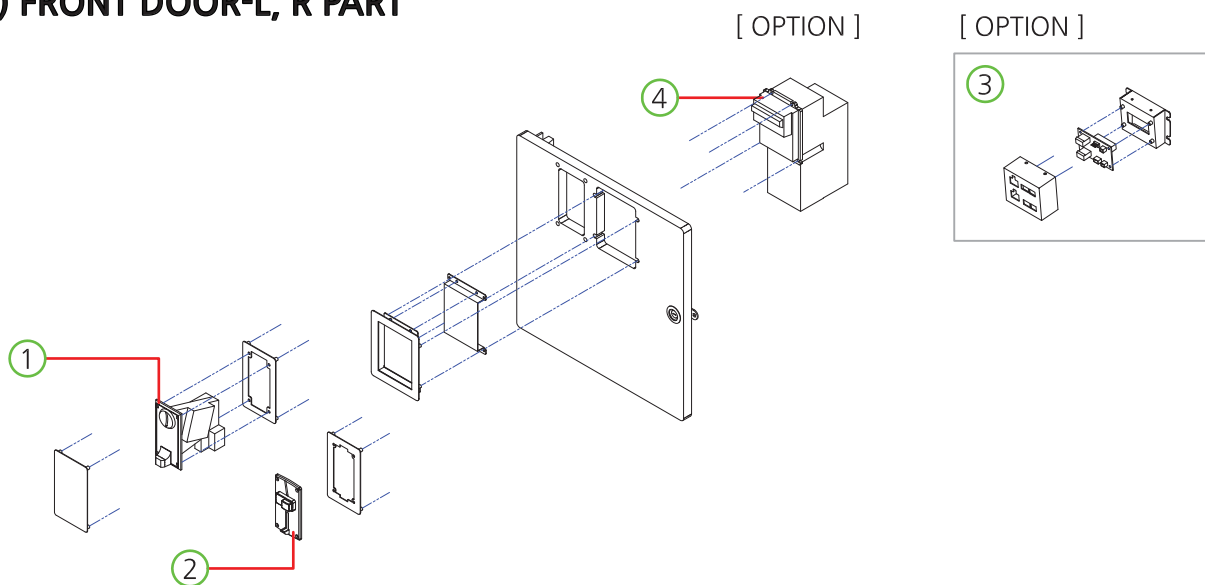

NO.	PART NAME	SPEC.	QUANTITY	CODE NO.
1	[INT] COIN SELECTOR	TW-389	1	MZZZ0COS052
2	[NAMCO] COIN SELECTOR	-	1	-
3	[OPTION] MEI BILL AC SSR PCB ASS'Y	-	1	ASBP0PCB015
4	[OPTION] BILL ACCEPT	-	1	-

(19) FRONT CABINET PROTECT ACRYL PART

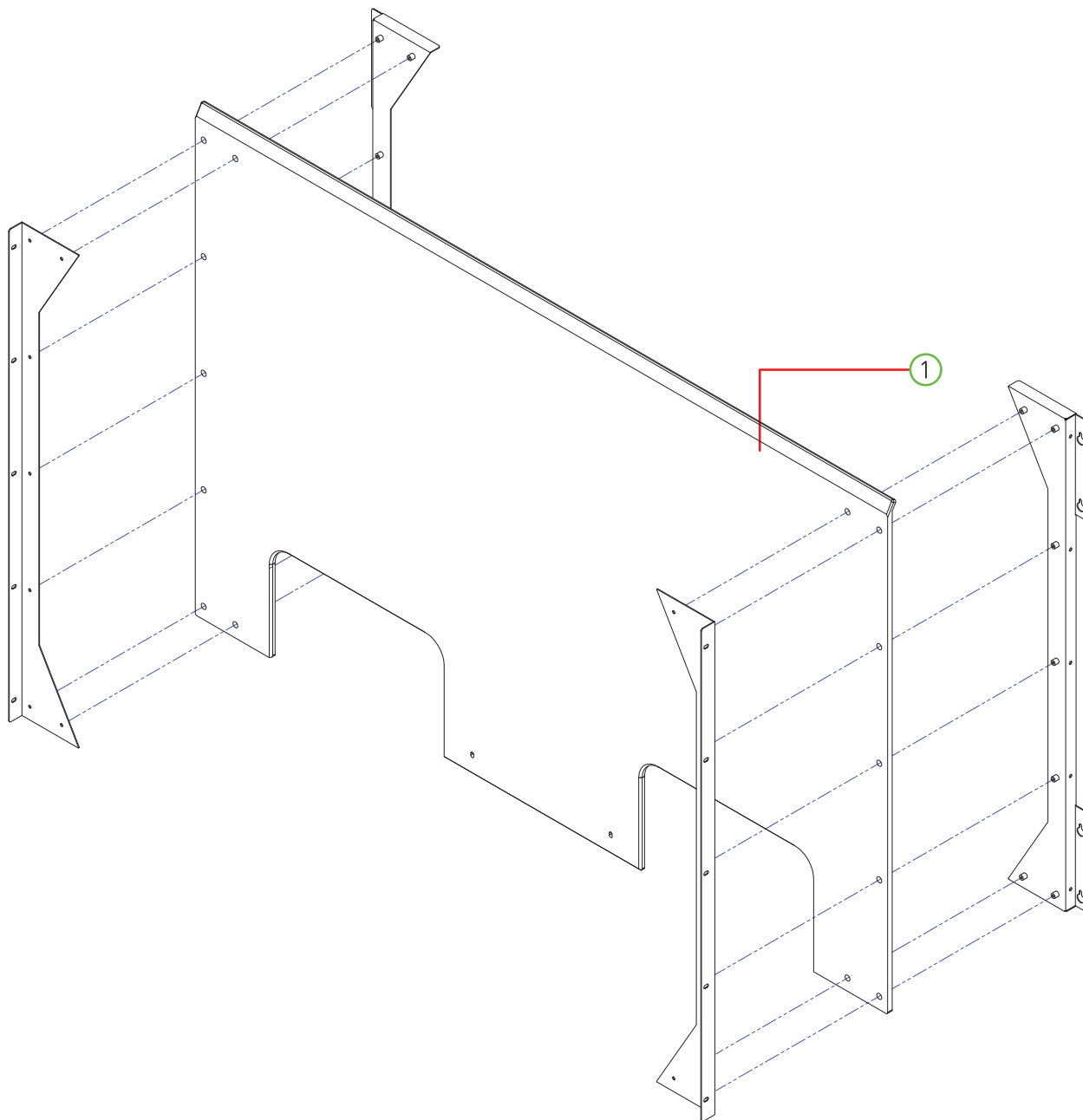

NO.	PART NAME	SPEC.	QUANTITY	CODE NO.
1	FRONT CABINET PROTECT ACRYL	ACRYL-8.0t	1	MJIE0ACR014

(20) FRONT DAMPER PART

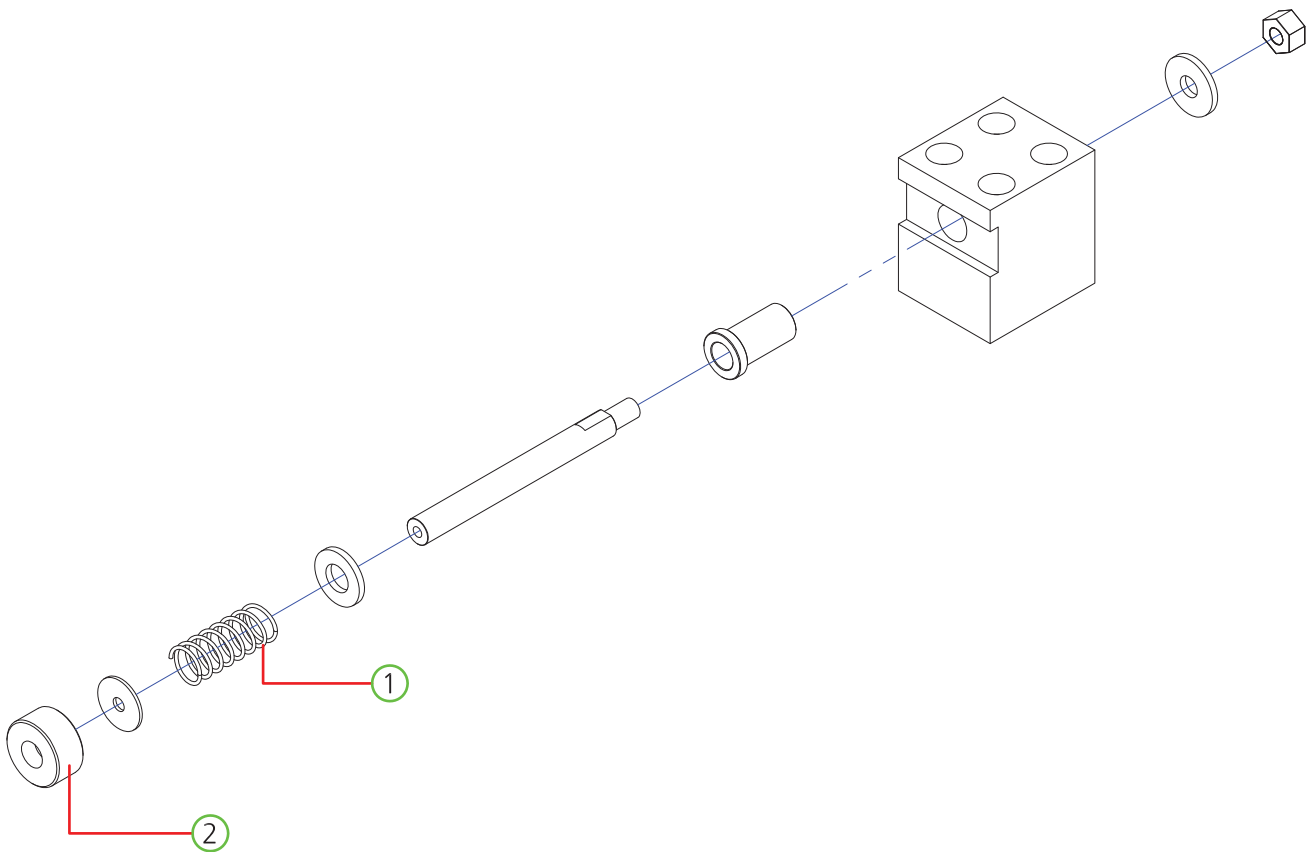

NO.	PART NAME	SPEC.	QUANTITY	CODE NO.
1	FRONT DAMPER TENSION SPRING	SUS304-1.0t	1	MJIE0SPR002
2	DAMPER URETAN	URETHAN	1	MJIE0PRO009

5-4. REAR CABINET PART

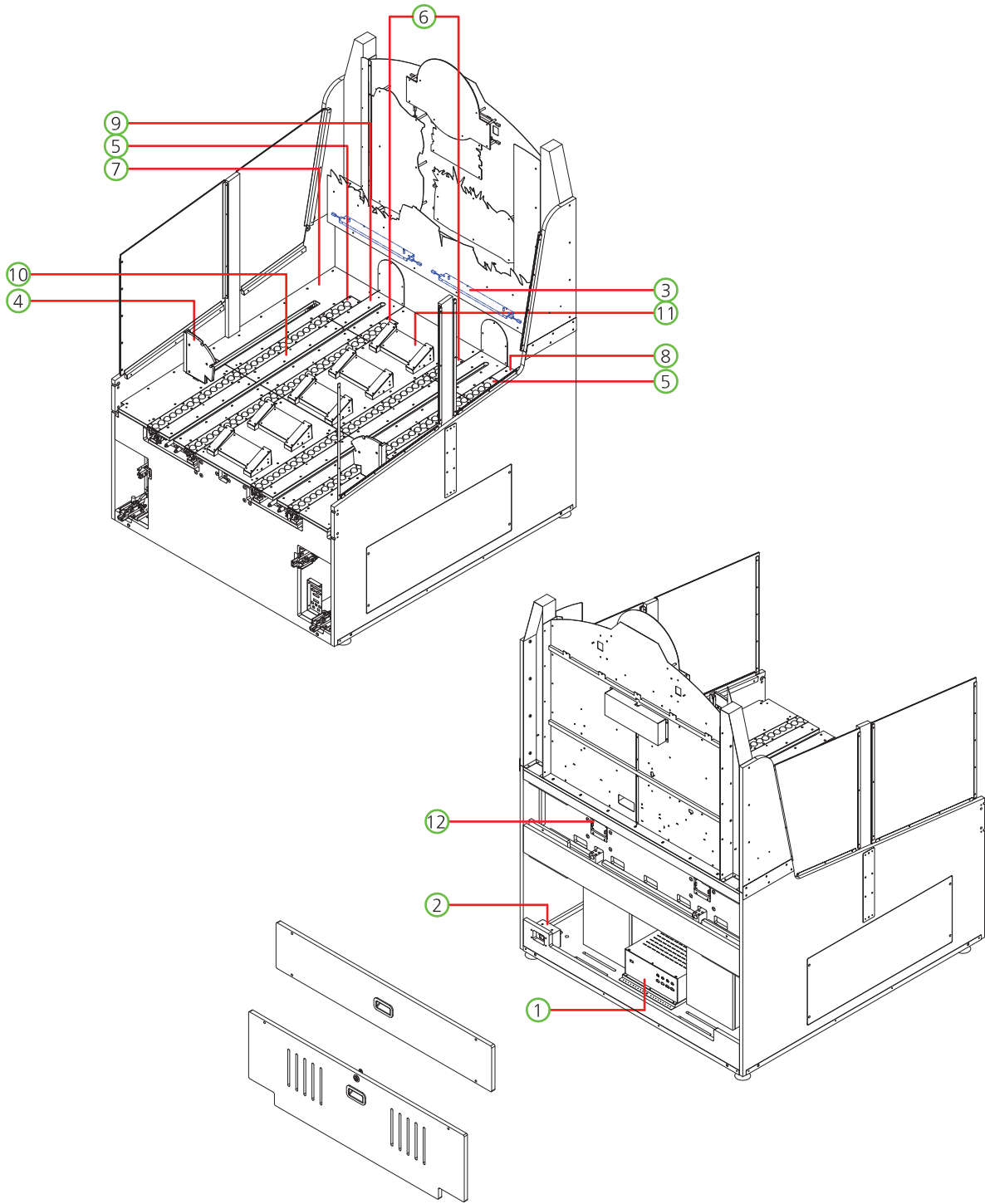

NO.	PART NAME	SPEC.	QUANTITY	CODE NO.
1	SMPS POWER PART	-	1	-
2	AC INPUT PART	-	1	-
3	UPPER CABINET FOREST BOTTOM LED PART	-	2	-
4	BIGWIN MOVEMENT-L, R PART	-	2	-
5	SIDE LED-L, R SENSOR LAST PART	-	2	-
6	SIDE LED-L, R NO SENSOR LAST PART	-	2	-
7	BIGWIN COVER PART-L PART	-	1	-
8	BIGWIN COVER PART-R PART	-	1	-
9	RAIL COVER REAR PART	-	2	-
10	RAIL COVER FRONT L, R PART	-	4	-
11	REAR CENTER COVER PART	-	1	-
12	FND PART	-	2	-

(1) SMPS POWER PART

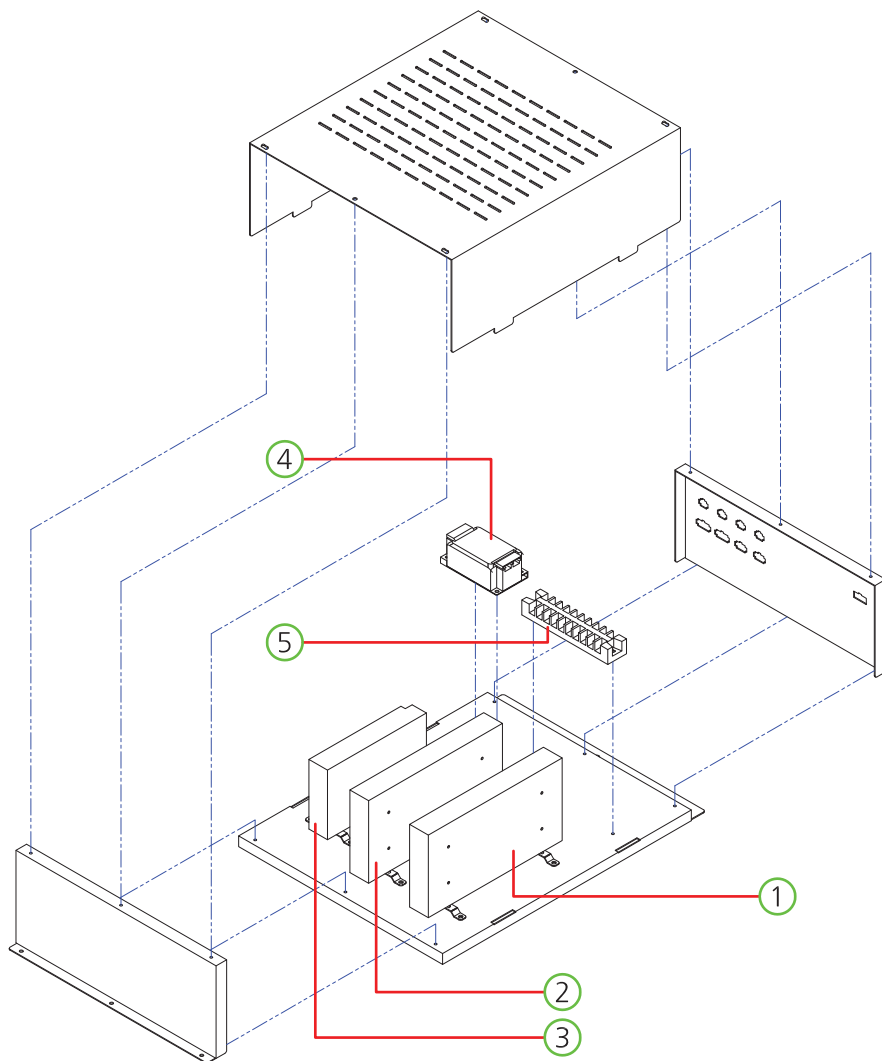

NO.	PART NAME	SPEC.	QUANTITY	CODE NO.
1	POWER SMPS	RSP-320-5V	1	MELE0SMP126
2	POWER SMPS	RSP-320-12V	1	MELE0SMP109
3	POWER SMPS	LRS-150F-24V	1	MELE0SMP085
4	NOISE FILTER	RNS-2Series	1	MELE0NOI009
5	TERMINAL BLOCK	250V 10P	1	MELE0TEB003

(2) AC INPUT PART

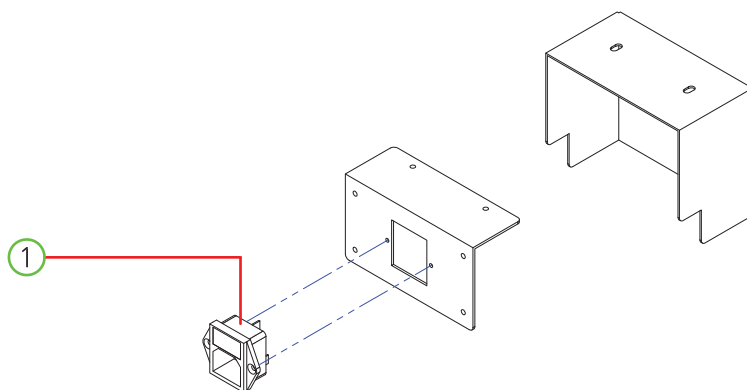

NO.	PART NAME	SPEC.	QUANTITY	CODE NO.
1	AC INPUT	DAC-13H WITH FUSE	1	MELE0SWI015

(3) UPPER CABINET FOREST BOTTOM LED PART

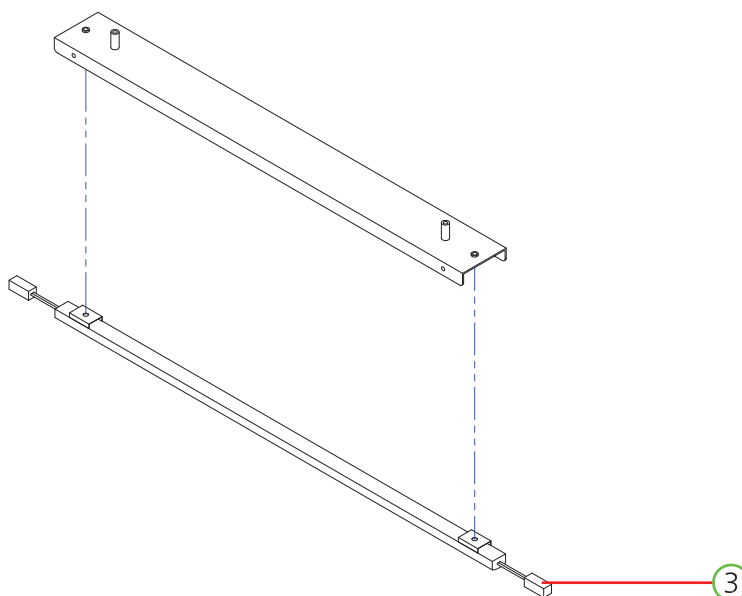

NO.	PART NAME	SPEC.	QUANTITY	CODE NO.
1	LED BAR 12V ASS'Y	460MM	1	AZZZ0PCB124

(4) BIGWIN MOVEMENT-L, R PART

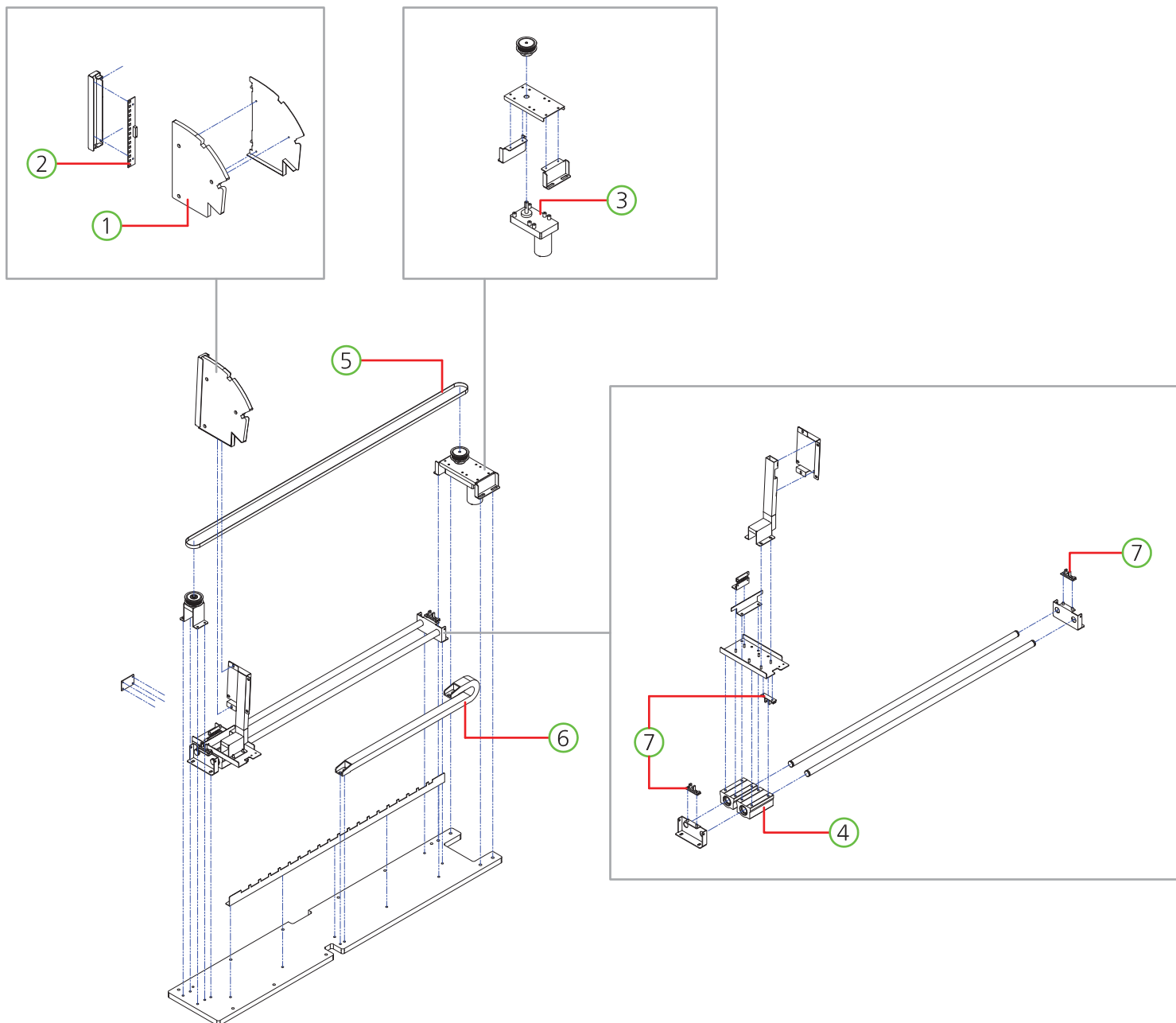

NO.	PART NAME	SPEC.	QUANTITY	CODE NO.
1	BIGWIN ACRYL-L, R	ACRYL-10t	1	AJIE0ACP009, 010
2	BIG WIN MAKER RGB LED PCB ASS'Y	-	1	AJIE0PCB005
3	MOTOR	KGV-ND3657U1, 60:1	1	MZZZ0MOT156
4	LM BEARING UNIT	SL16UU	2	MZZZ0BEA136
5	TIMMING BELT	828XL-037	1	MZZZ0BEL045
6	CABLE CHAIN	KJP-0180-1B-R18*32LINK	1	MZZZ0CBC017
7	PHOTO-INT1_ANGLE PCB ASS'Y	-	3	AZZZ0PCB103

(5) SIDE LED-L, R SENSOR LAST PART

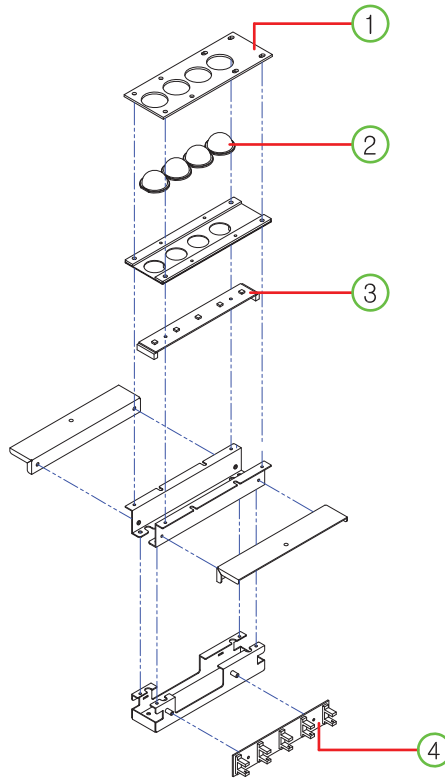

NO.	PART NAME	SPEC.	QUANTITY	CODE NO.
1	RAIL DOME COVER ACRYL	ACRYL-2.7t	1	MJIE0ACR025
2	DOME ACRYL CAP	∅30	4	MJIE0PLA001
3	SLOPE SENSOR PCB ASS'Y	INT1x5	1	AJIE0PCB002
4	SIDE LED PCB ASS'Y	RGB 5EA	1	AJIE0PCB003

(6) SIDE LED-L, R NO SENSOR LAST PART

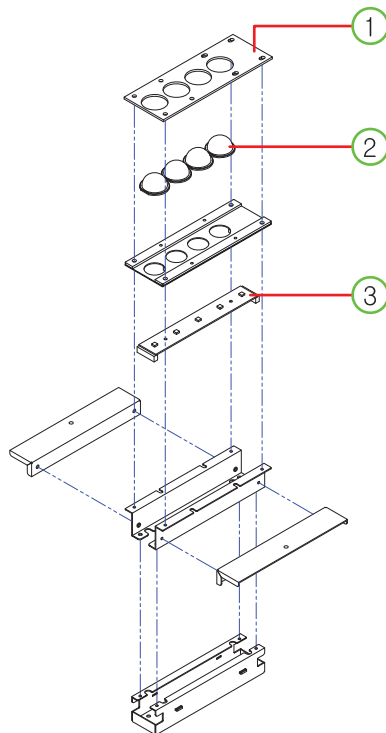

NO.	PART NAME	SPEC.	QUANTITY	CODE NO.
1	RAIL DOME COVER ACRYL	ACRYL-2.7t	1	MJIE0ACR025
2	DOME ACRYL CAP	∅30	4	MJIE0PLA001
3	SLOPE SENSOR PCB ASS'Y	INT1x5	1	AJIE0PCB002

(7) BIGWIN COVER PART-L PART

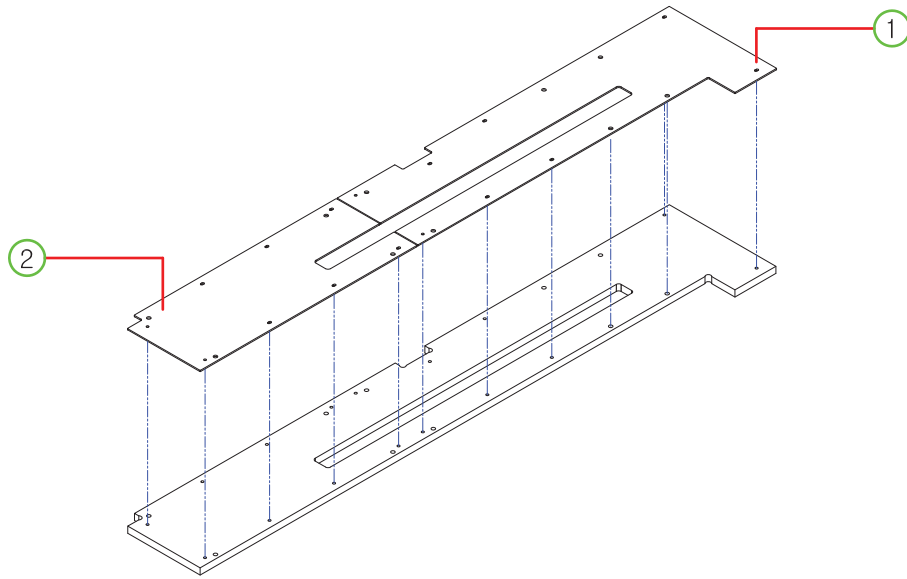

NO.	PART NAME	SPEC.	QUANTITY	CODE NO.
1	REAR CABINET BIGWIN COVER REAR ACRYL-L	ACRYL-2.7t	1	AJIE0ACP011
2	REAR CABINET BIGWIN COVER FRONT ACRYL-L	ACRYL-2.7t	1	AJIE0ACP012

(8) BIGWIN COVER PART-R PART

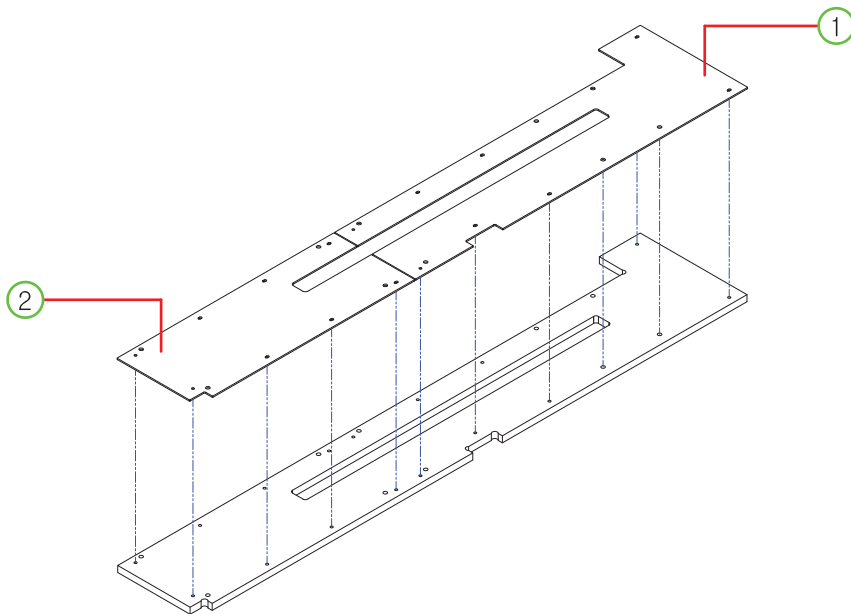

NO.	PART NAME	SPEC.	QUANTITY	CODE NO.
1	REAR CABINET BIGWIN COVER REAR ACRYL-R	ACRYL-2.7t	1	AJIE0ACP013
2	REAR CABINET BIGWIN COVER FRONT ACRYL-R	ACRYL-2.7t	1	AJIE0ACP014

(9) RAIL COVER REAR PART

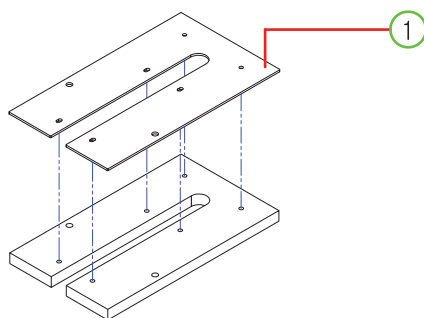

NO.	PART NAME	SPEC.	QUANTITY	CODE NO.
1	REAR CABINET RAIL COVER REAR ACRYL	ACRYL-2.7t	1	AJIE0ACP015

(10) RAIL COVER FRONT L, R PART

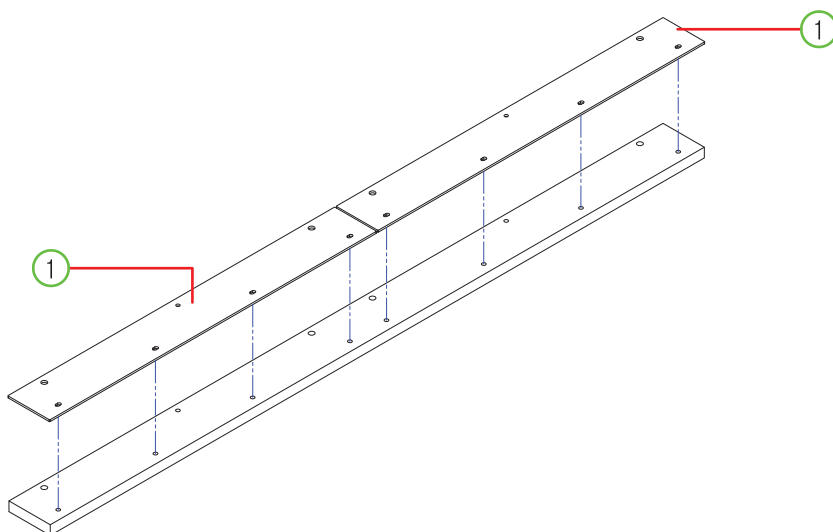

NO.	PART NAME	SPEC.	QUANTITY	CODE NO.
1	CABINET RAIL COVER ACRYL	ACRYL-2.7t	2	AJIE0ACP016

(11) REAR CENTER COVER PART

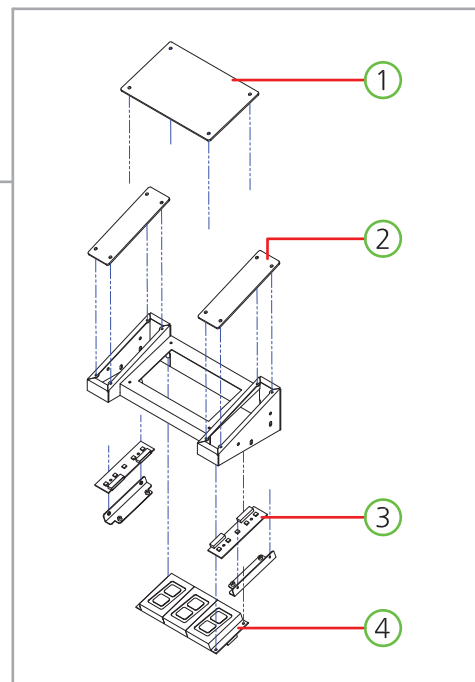
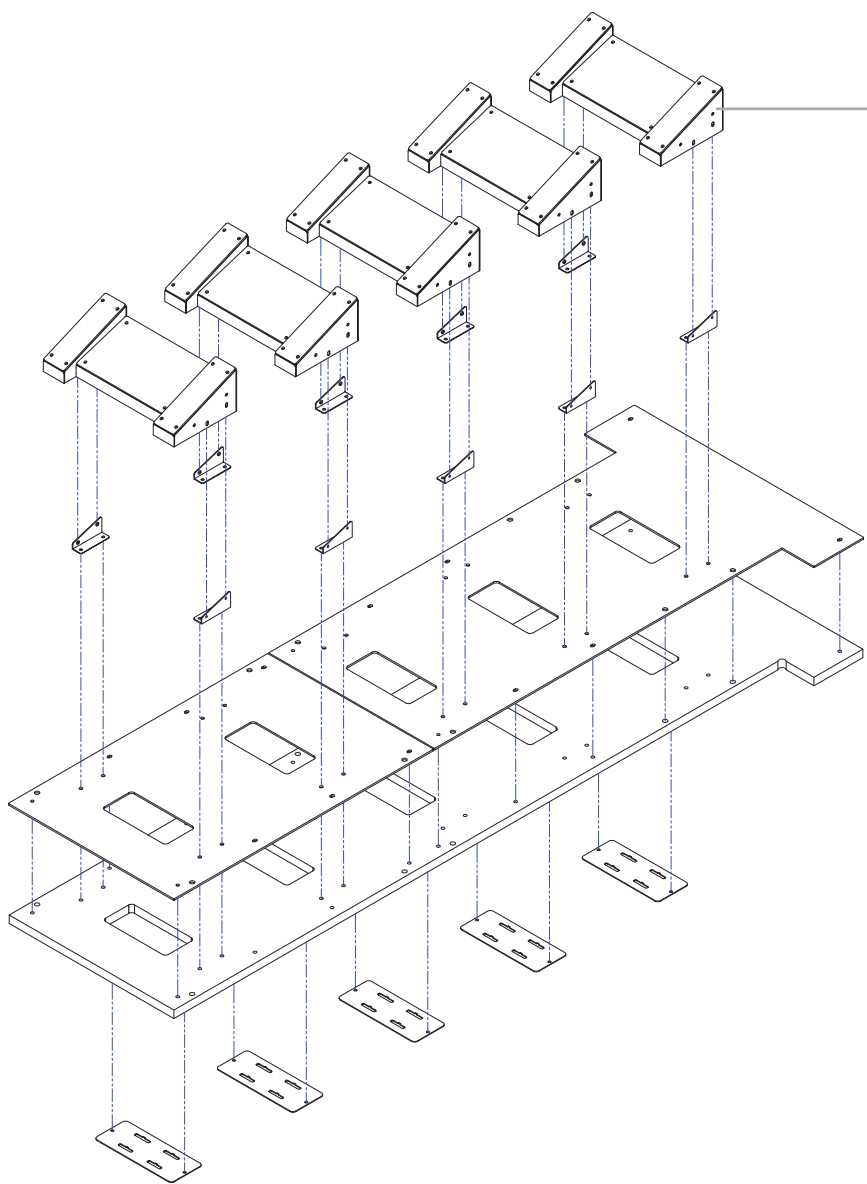

NO.	PART NAME	SPEC.	QUANTITY	CODE NO.
1	SCORE FND COVER ACRYL	ACRYL-2.7t	5	AJIE0ACP029
2	SCORE FND SIDE COVER ACRYL	ACRYL-2.7t	10	MJIE0ACR037
3	SCORE LED PCB ASS'Y	RGB 5EA	2	AJIE0PCB004
4	FND PCB ASS'Y	4870-3(STRAIGHT)	5	AFND0PCB027

(12) FND PART

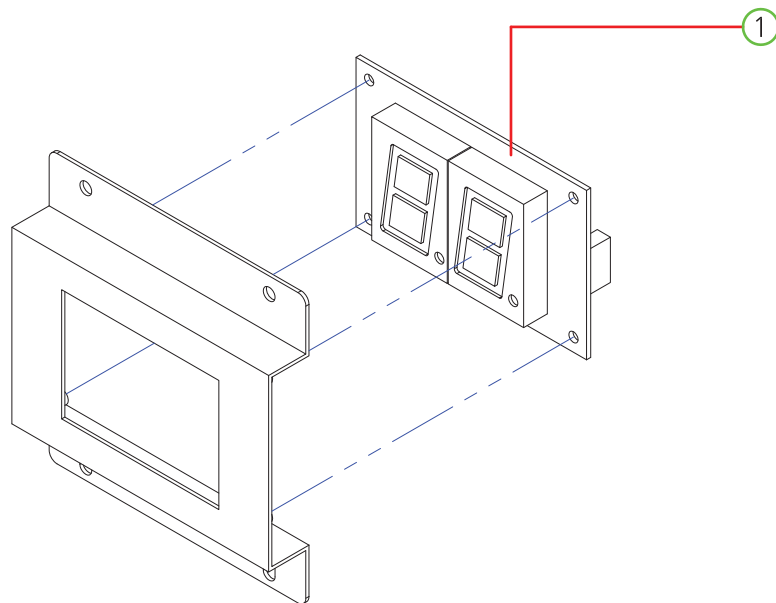

NO.	PART NAME	SPEC.	QUANTITY	CODE NO.
1	FND PCB ASS'Y	2941-2(STRAIGHT)	1	AFND0PCB003

6. WARRANTY ITEM & PART PICTURE

- BACKGROUND PART

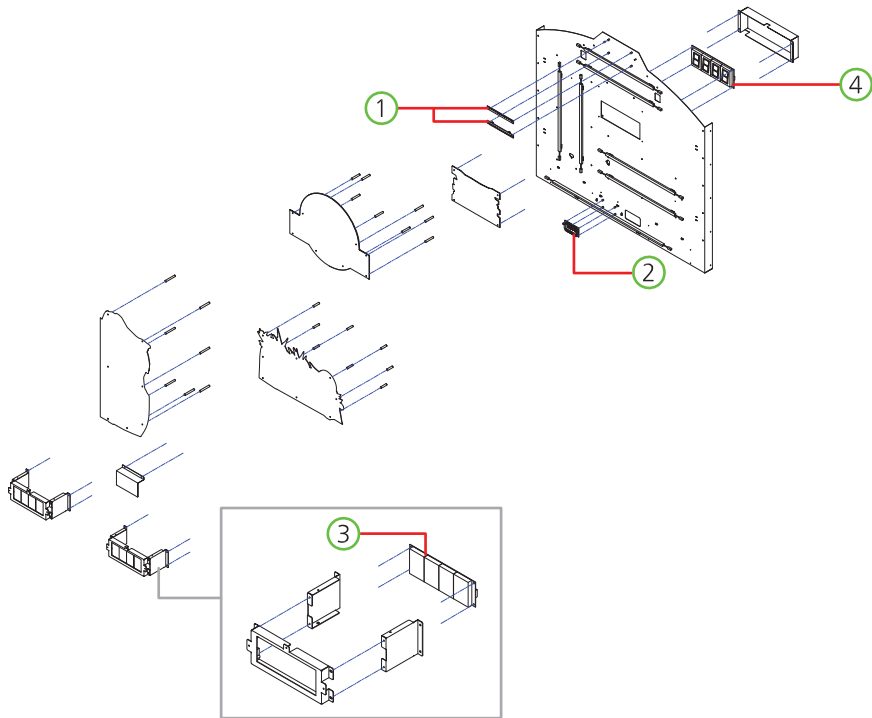

- MAIN BOARD BOX PART

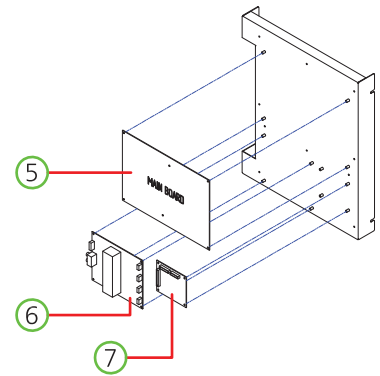

- FRONT SIDE PCB PART

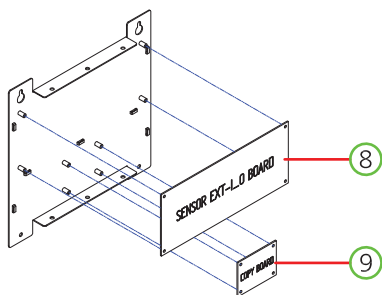

- CONTROL PANEL PART

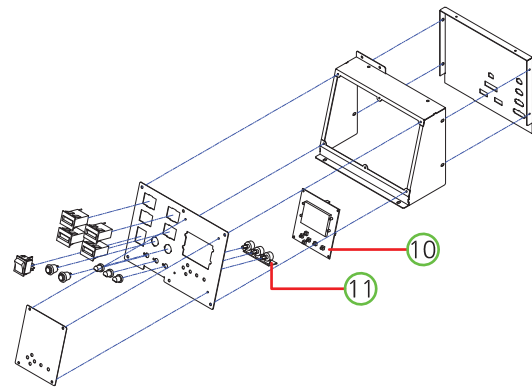

- FRONT DECO-L, R PART

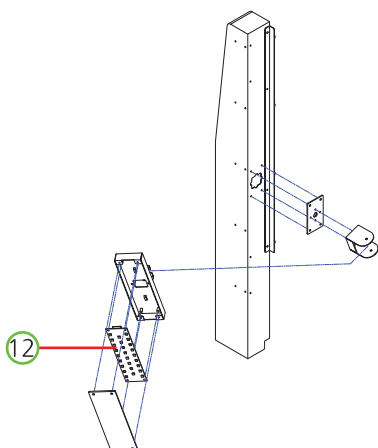

- SIDE LED SENSOR-L, R PART

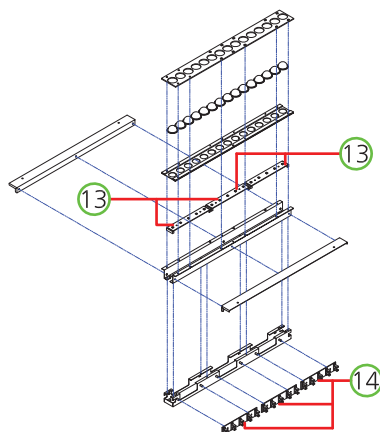

- SIDE GO LED-L, R PART

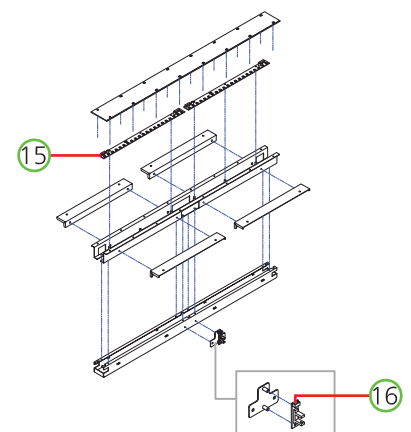

- SIDE LED NO SENSOR-L, R PART

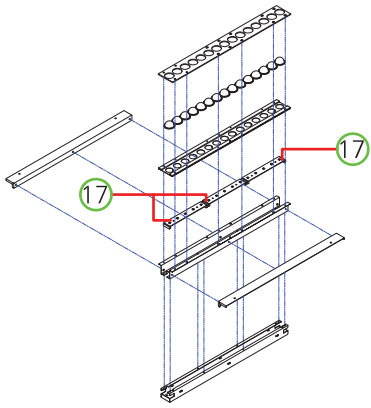

- CAR STOPPER PART

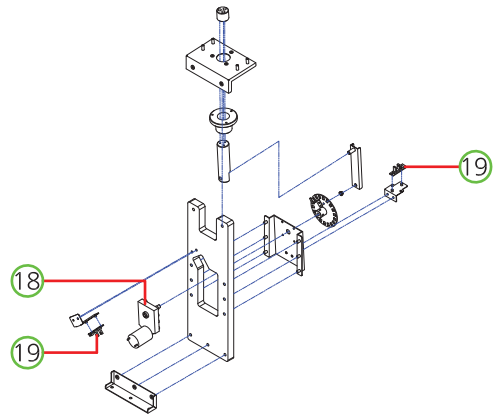

- FRONT CENTER COVER PART

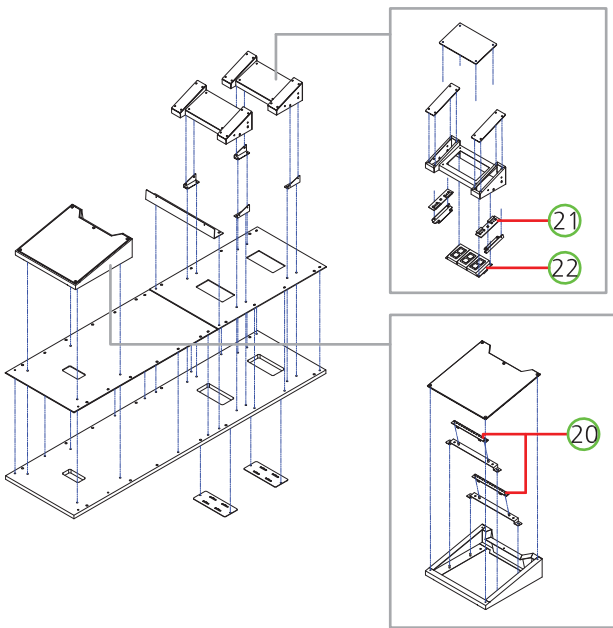

- BUTTON PART

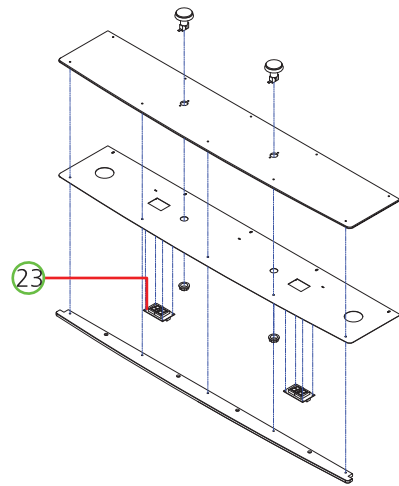

- SMPS POWER PART

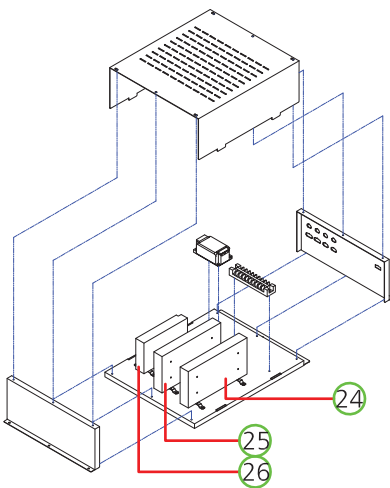

- BIGWIN MOVEMENT-L, R

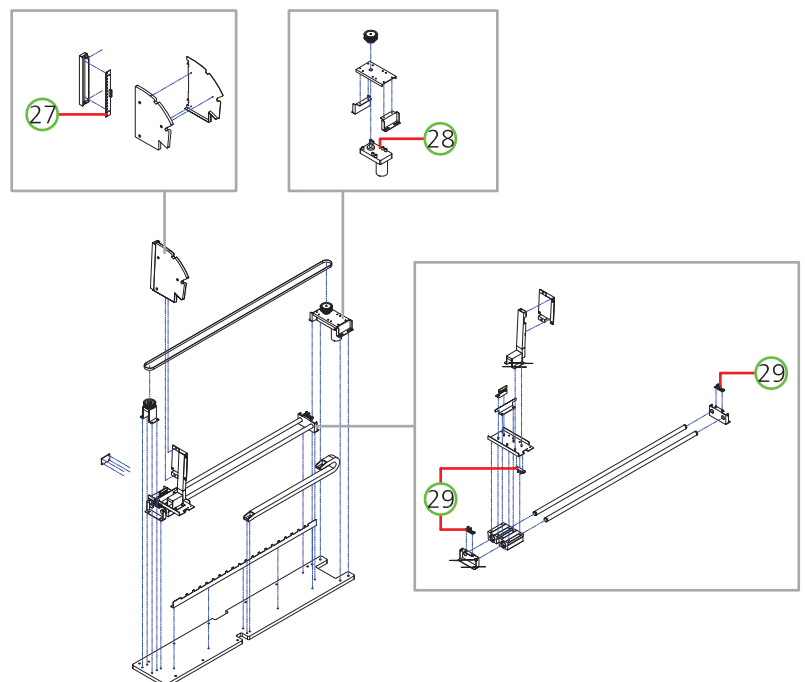

- SIDE LED-L, R SENSOR LAST PART

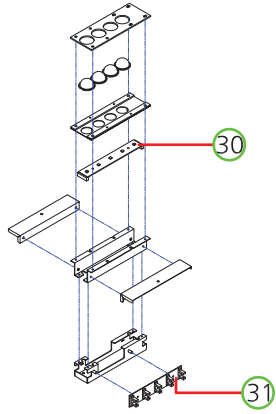

- SIDE LED-L, R NO SENSOR LAST PART

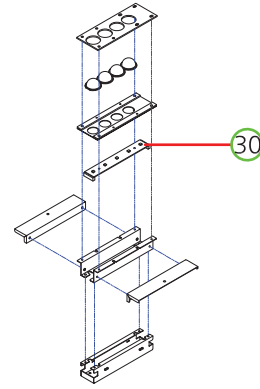

- REAR CENTER COVER PART

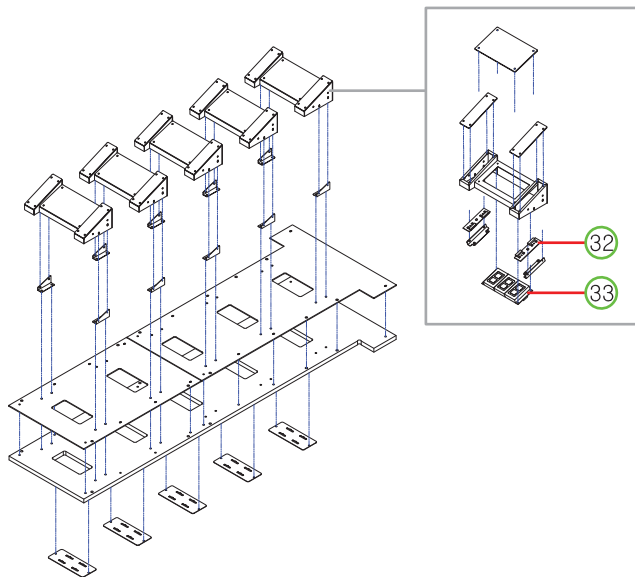



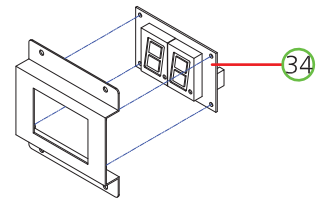







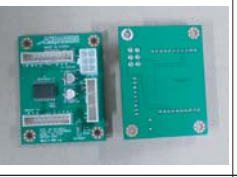

- FND PART









NO.	PIC	PART NAME	SPEC.	QTY	CODE NO.	WARRANTY	
						6 Month	One Year
①	○	JWIE LED PCB ASS'Y	WHITE 14EA	2	AJIE0PCB006		○
②	○	FND EXT IO PCB ASS'Y	90x50 16BIT EXT	1	ABSP0PCB005		○
③	○	FND PCB ASS'Y	4870-4(STRAIGHT)	1	AFND0PCB009		○
④	○	FND PCB ASS'Y	6390-4(STRAIGHT)	1	AFND0PCB011		○
⑤	○	MAIN IO PCB ASS'Y	-	1	AJIE0PCB007		○
⑥	○	DIGITAL AMP PCB ASS'Y	2.1CH	1	APUJ0PCB002		○
⑦	○	WS2812B IO PCB ASS'Y	-	1	AZZZ0PCB185		○
⑧	○	SLOPE SENSOR EXT IO PCB ASS'Y	64 PORT	1	AJIE0PCB001		○
⑨	○	DISPLAY COPY PCB ASS'Y	-	1	AGST0PCB008		○
⑩	○	SETUP LCD PCB ASS'Y	-	1	AZZZ0PCB113		○
⑪	○	VOLUME PCB ASS'Y	3CH	1	APUJ0PCB005		○
⑫	○	SPOT LED PCB ASS'Y	WHITE	1	ABAP0PCB008		○
⑬	○	SIDE LED PCB ASS'Y	RGB 5EA	3	AJIE0PCB003		○
⑭	○	SLOPE SENSOR (INT1x5) PCB ASS'Y	-	3	AJIE0PCB002		○
⑮	○	WS2813B LED PCB 21EA-R ASS'Y	21EA-R	2	APLX0PCB008		○
⑯	○	PHOTO INT-1 PCB ASS'Y	-	1	AZZZ0PCB103		○
⑰	○	SIDE LED PCB ASS'Y	RGB 5EA	3	AJIE0PCB003		○
⑱	○	MOTOR	KGE-3448S1, 62:1	1	MZZZ0MOT157	○	
⑲	○	PHOTO-INT1_ANGLE PCB ASS'Y	-	2	AZZZ0PCB103		○
⑳	○	JWIE LED PCB ASS'Y	WHITE 14EA	2	AJIE0PCB006		○
㉑	○	SCORE LED PCB ASS'Y	RGB 5EA	4	AJIE0PCB004		○
㉒	○	FND PCB ASS'Y	4870-3(STRAIGHT)	2	AFND0PCB027		○
㉓	○	FND PCB ASS'Y	2941-2(STRAIGHT)	2	AFND0PCB003		○
㉔	○	POWER SMPS	RSP-320-5V	1	MELE0SMP126		○
㉕	○	POWER SMPS	RSP-320-12V	1	MELE0SMP109		○
㉖	○	POWER SMPS	LRS-150F-24V	1	MELE0SMP085		○
㉗	○	BIG WIN MAKER RGB LED PCB ASS'Y	-	1	AJIE0PCB005		○
㉘	○	MOTOR	KGV-ND3657U1, 60:1	1	MZZZ0MOT156	○	
㉙	○	PHOTO-INT1_ANGLE PCB ASS'Y	-	1	AZZZ0PCB103		○
㉚	○	SLOPE SENSOR PCB ASS'Y	INT1x5	2	AJIE0PCB002		○
㉛	○	SIDE LED PCB ASS'Y	RGB 5EA	1	AJIE0PCB003		○
㉜	○	SCORE LED PCB ASS'Y	RGB 5EA	2	AJIE0PCB004		○
㉝	○	FND PCB ASS'Y	4870-3(STRAIGHT)	5	AFND0PCB027		○
㉞	○	FND PCB ASS'Y	2941-2(STRAIGHT)	2	AFND0PCB003		○



1	2	3	4	5	6
					
AJIE0PCB006	ABSP0PCB005	AFND0PCB009	AFND0PCB011	AJIE0PCB007	APUJ0PCB002

7	8	9	10	11	12
					
AZZZ0PCB185	AJIE0PCB001	AGST0PCB008	AZZZ0PCB113	APUJ0PCB005	ABAP0PCB008

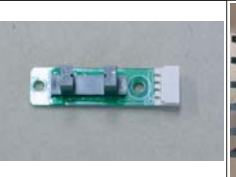
13	14	15	16	17	18
					
AJIE0PCB003	AJIE0PCB002	APLX0PCB008	AZZZ0PCB103	AJIE0PCB003	MZZZ0MOT157

19	20	21	22	23	24
					
AZZZ0PCB103	AJIE0PCB006	AJIE0PCB004	AFND0PCB027	AFND0PCB003	MELE0SMP126

25	26	27	28	29	30
					
MELE0SMP109	MELE0SMP085	AJIE0PCB005	MZZZ0MOT156	AZZZ0PCB103	AJIE0PCB002

31	32	33	34
			
AJIE0PCB003	AJIE0PCB004	AFND0PCB027	AFND0PCB003

* HOW TO CONNECT THE CARD SWIPE



[BUTTON COVER ACRYL]

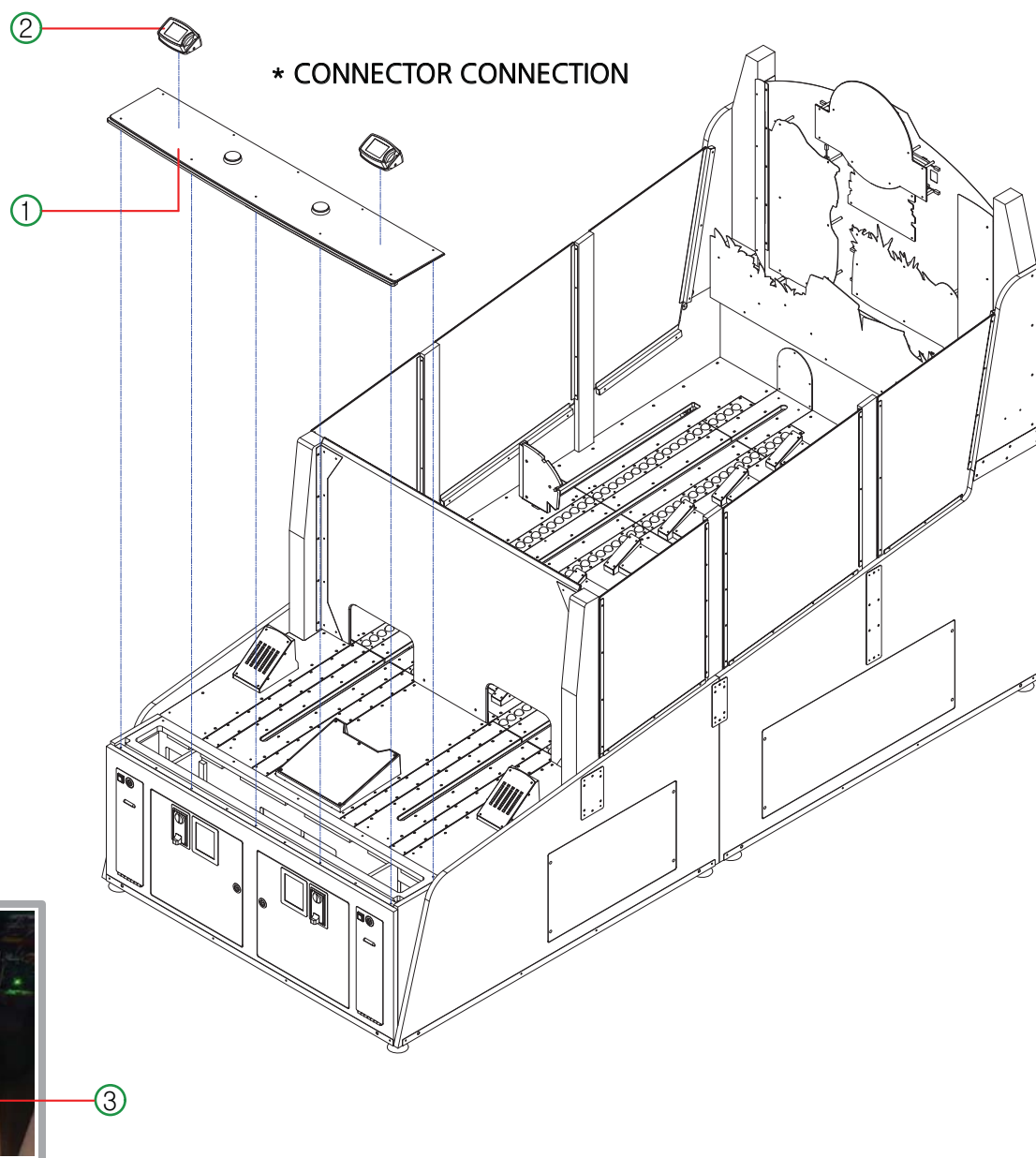

- Power off the machine, detach ① BUTTON COVER ACRYL. (M4 Bolt, 10ea) And make the hole by using proper tool.

- Install ② CARD SWIPE as the picture.

* Connect CARD SWIPE connector inside of TABLE ACRYLIC.

- And then, open FRONT DOOR and power on ③ power switch.

MARK	DATE	REVISION

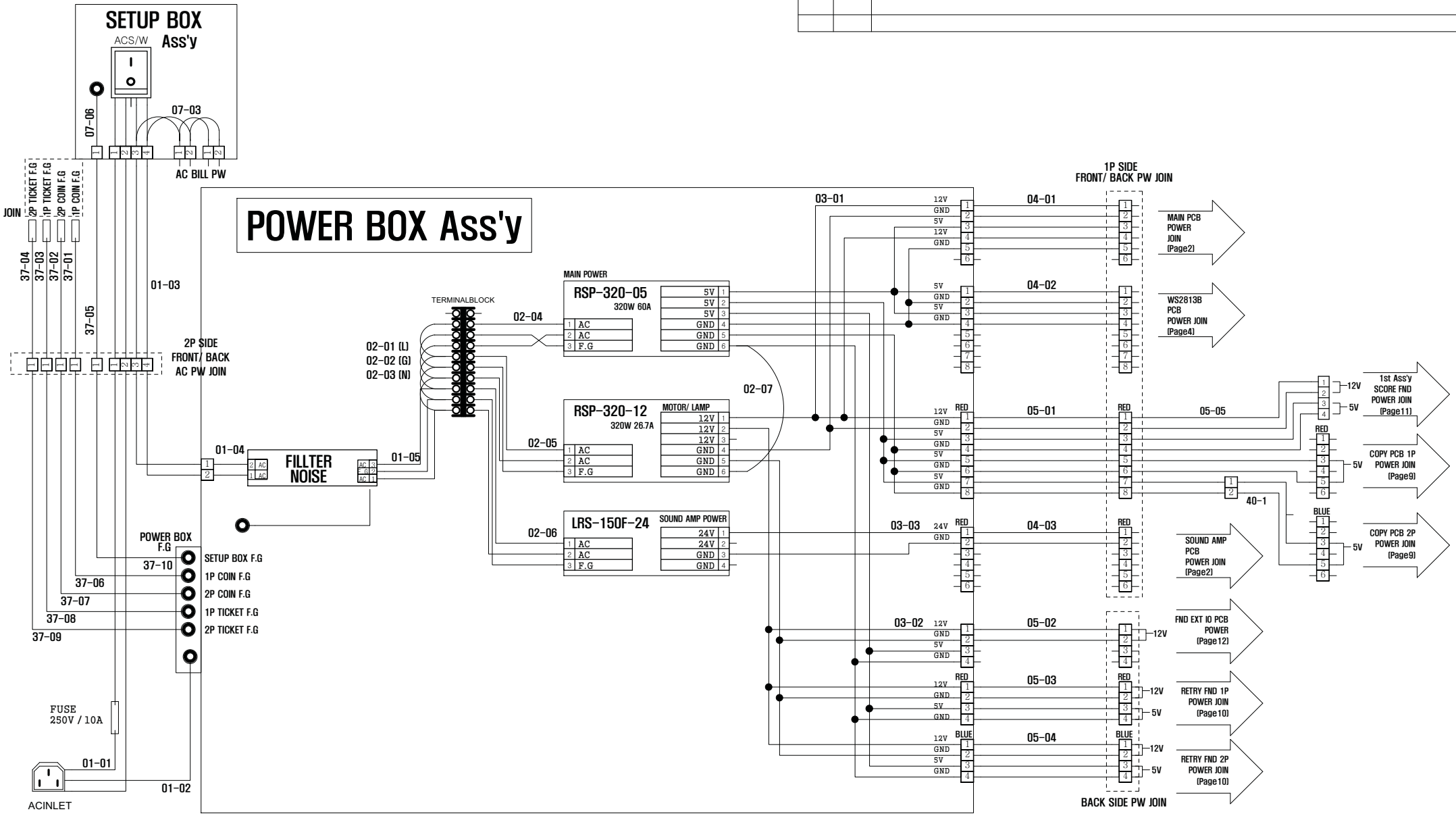

POWER PART

DRAWN BY	EXAMINATION	APPROVED BY	ITEM	JWFK
S.J.LEE			NAME	POWER BOX
			DWG.NO	1 of 12
			CODE.NO	
			DATE	

ANDAMIRO

MARK	DATE	REVISION

SETUP BOX Ass'y

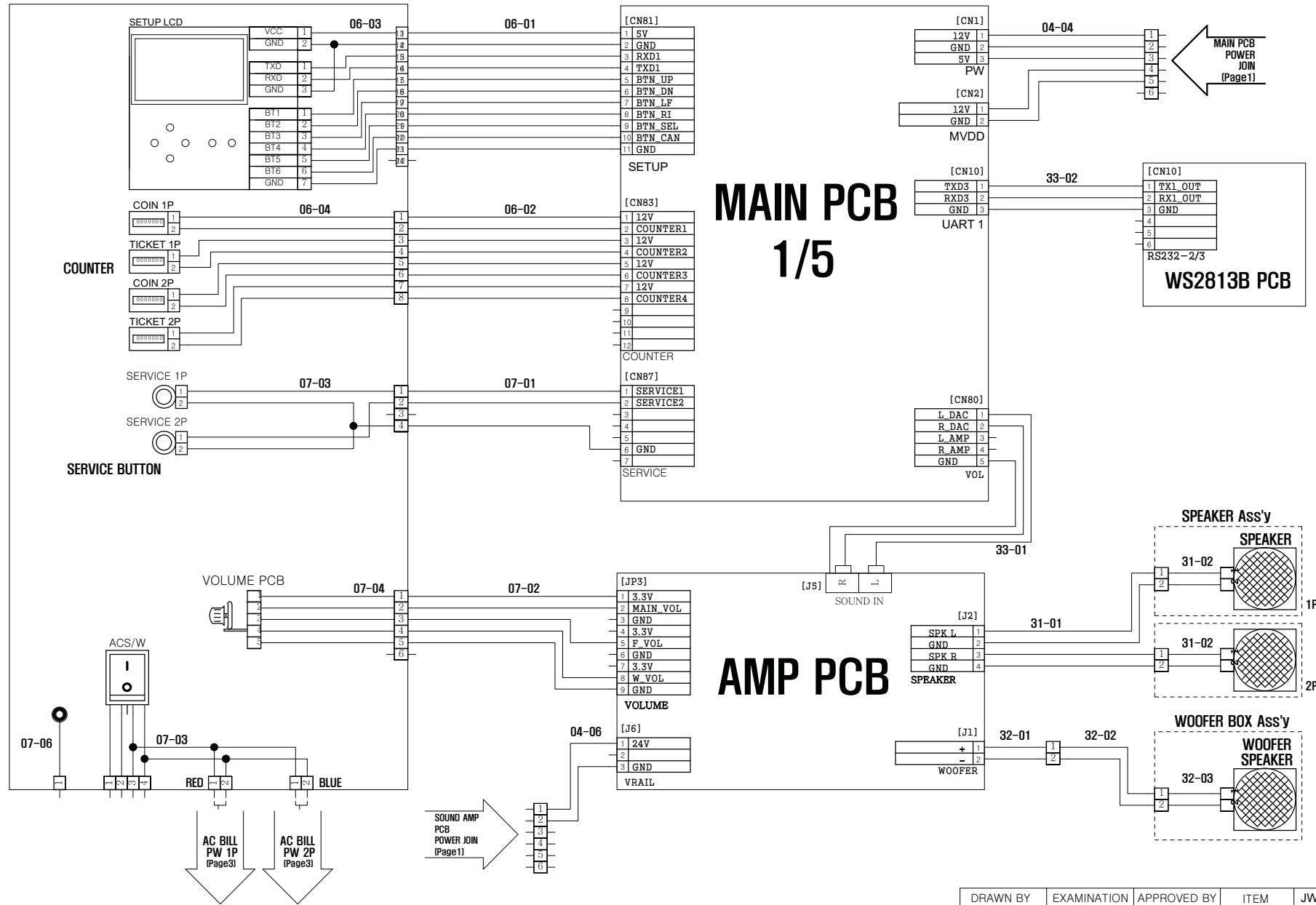

DRAWN BY	EXAMINATION	APPROVED BY	ITEM NAME	JWFK
S.J.LEE			NAME	SETUP
			DWG.NO	2 of 13
			CODE.NO	
			DATE	

ANDAMIRO

FRONT DOOR

MARK	DATE	REVISION

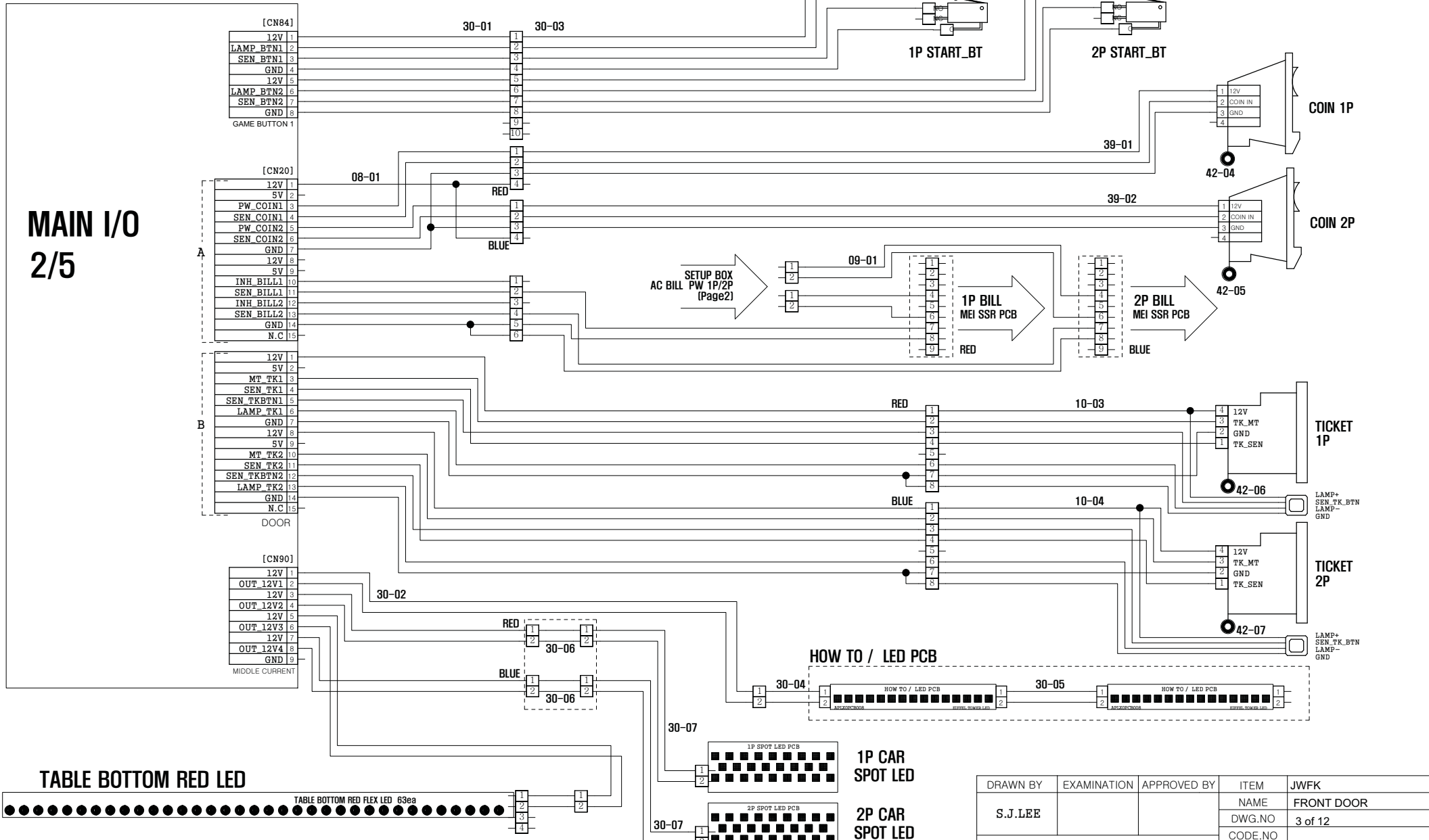

DRAWN BY	EXAMINATION	APPROVED BY	ITEM	JWFK
S.J.LEE			NAME	FRONT DOOR
			DWG.NO	3 of 12
			CODE.NO	
			DATE	

ANDAMIRO

MARK	DATE	REVISION

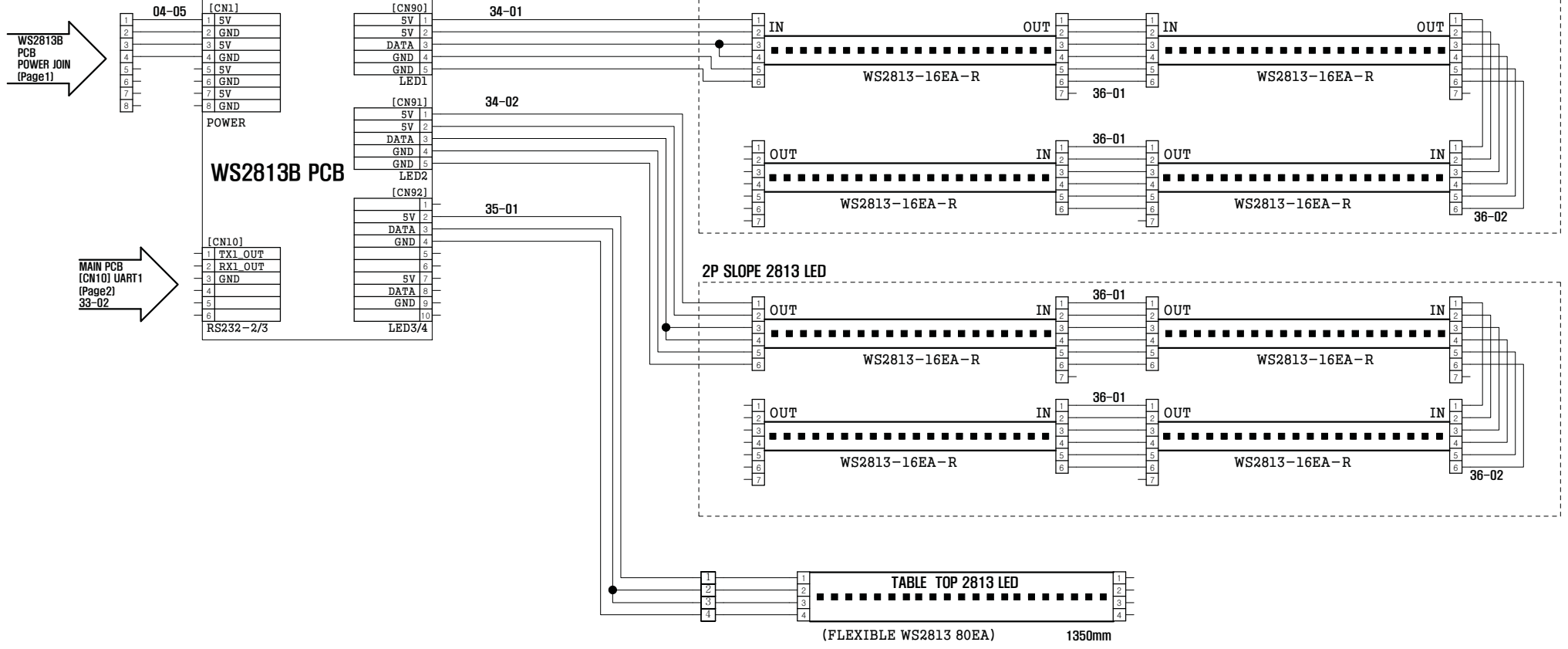

DRAWN BY	EXAMINATION	APPROVED BY	ITEM	JWFK
S.J.LEE			NAME	TABLE WS2813
ANDAMIRO			DWG.NO	4 of 12
			CODE.NO	
			DATE	

1P SLOPE SENSOR EXT-IO

MARK	DATE	REVISION

MAIN I/O 3/5

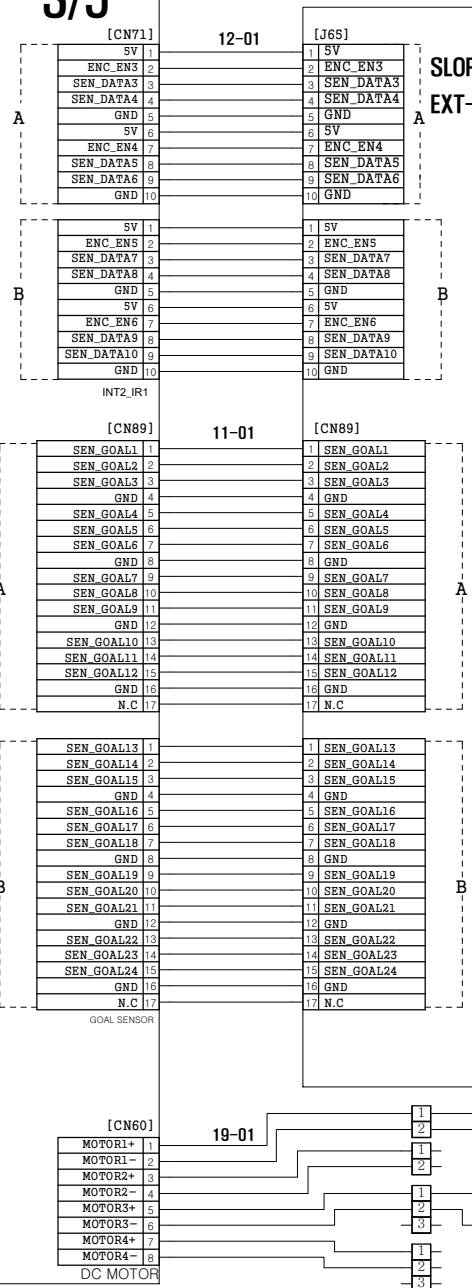

SLOPE SENSOR 1~3 Ass'y

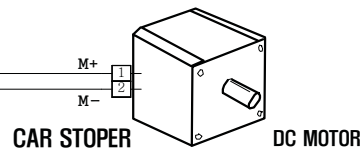
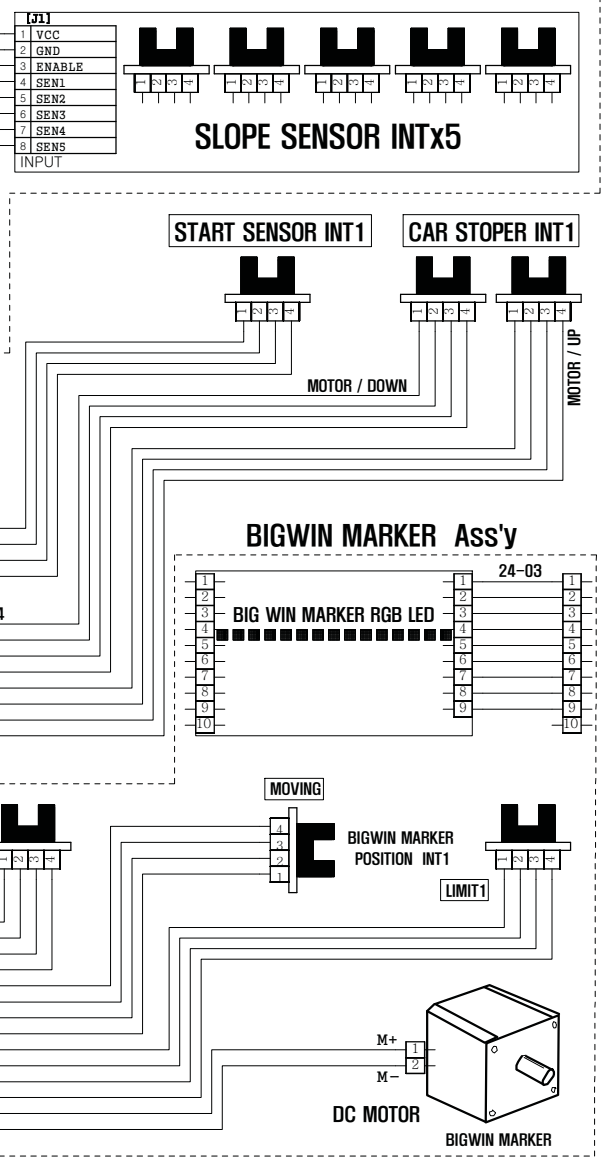
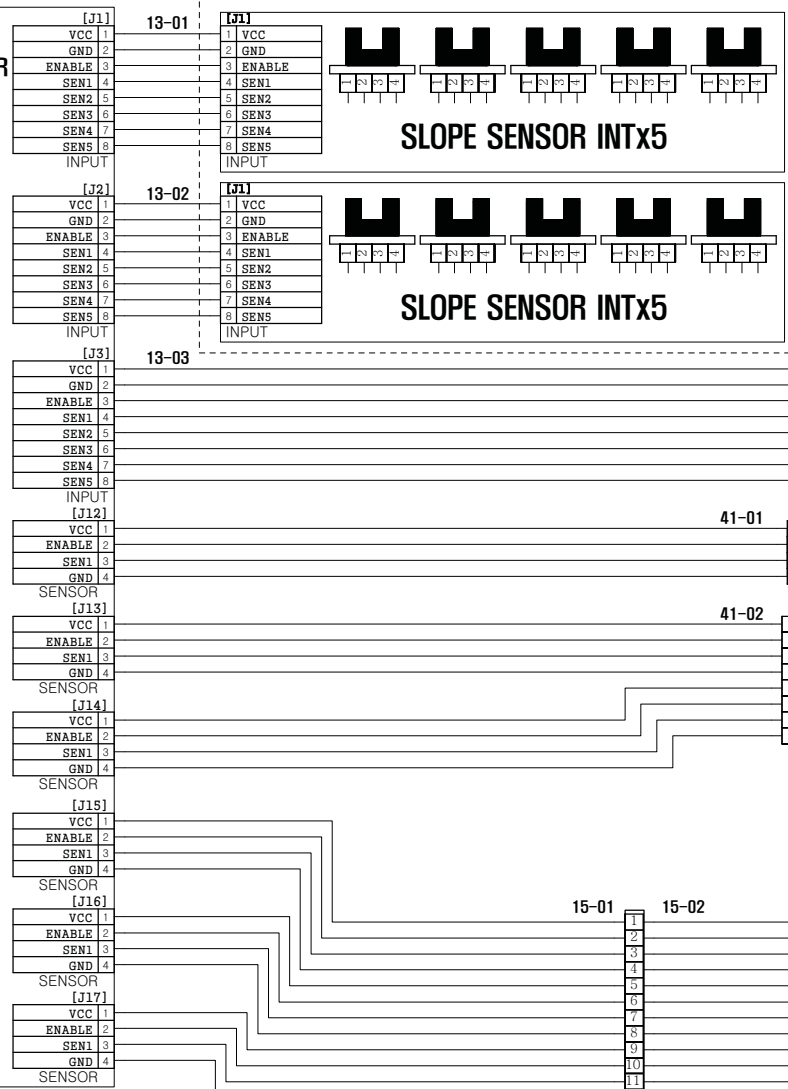

DRAWN BY	EXAMINATION	APPROVED BY	ITEM	JWFK
S.J.LEE			NAME	1P SLOPE SENSOR FRONT SIDE
			DWG.NO	5 of 12
			CODE.NO	
			DATE	

ANDAMIRO

2P SLOPE SENSOR EXT-IO

MARK	DATE	REVISION

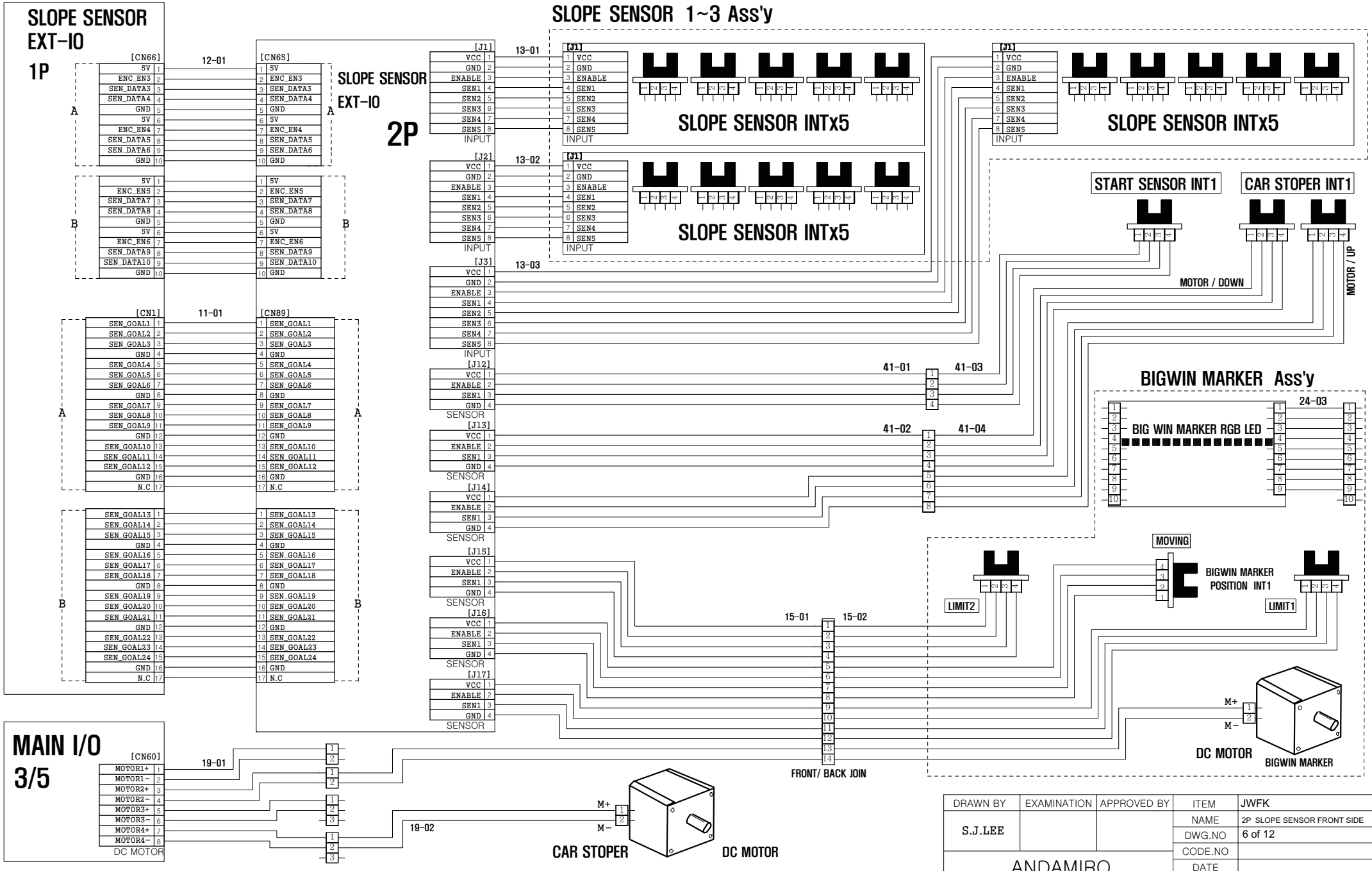

DRAWN BY	EXAMINATION	APPROVED BY	ITEM	JWFK
S.J.LEE			NAME	2P SLOPE SENSOR FRONT SIDE
			DWG.NO	6 of 12
			CODE.NO	
			DATE	

ANDAMIRO

MARK	DATE	REVISION

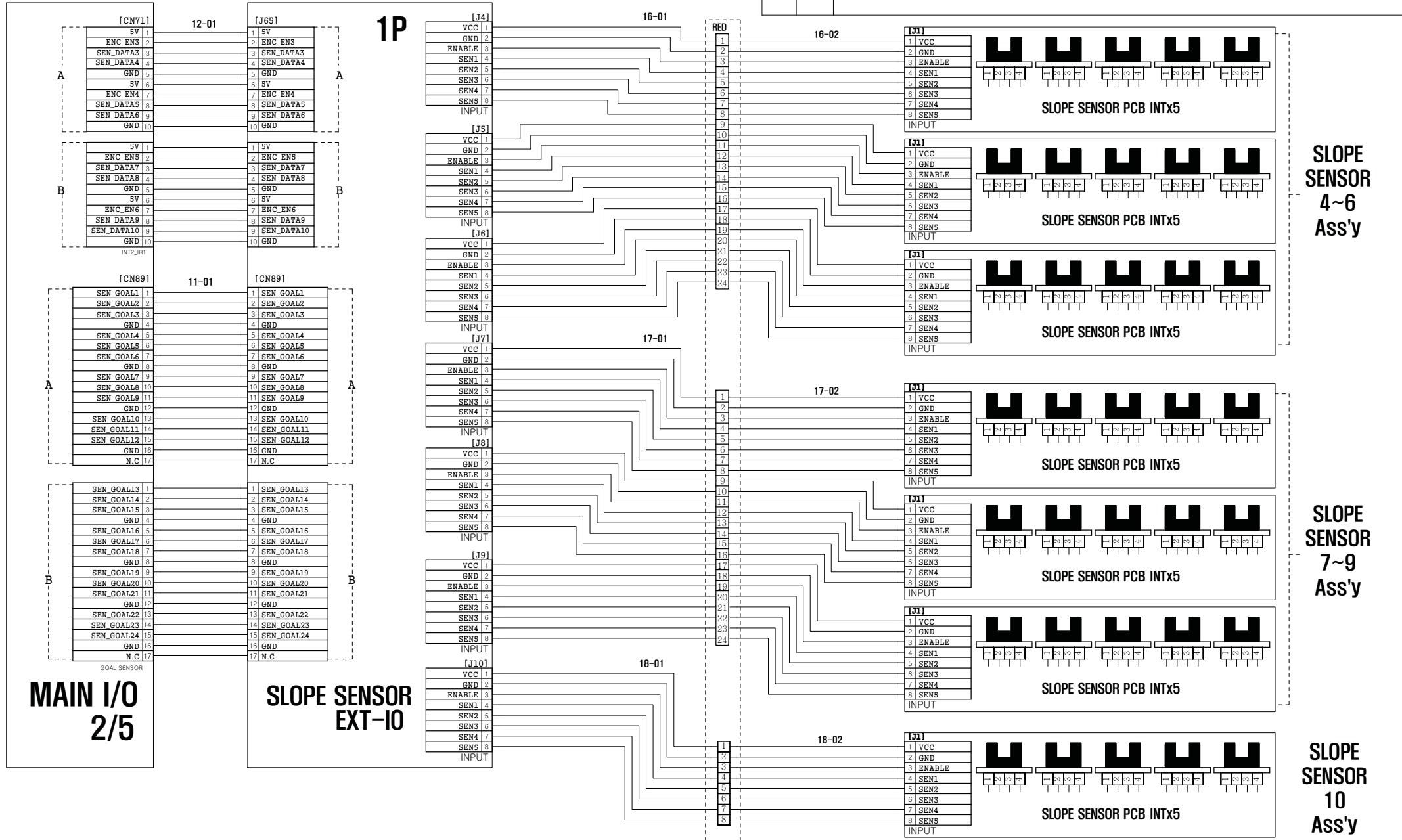

MAIN I/O
2/5

SLOPE SENSOR
EXT-I/O

SLOPE SENSOR
4~6
Ass'y

SLOPE SENSOR
7~9
Ass'y

SLOPE SENSOR
10
Ass'y

1P SLOPE SENSOR REAR PART

DRAWN BY	EXAMINATION	APPROVED BY	ITEM	JWFK
S.J.LEE			NAME	1P SLOPE SENSOR REAR PART
			DWG.NO	7 of 12
			CODE.NO	
			DATE	

ANDAMIRO

MARK	DATE	REVISION

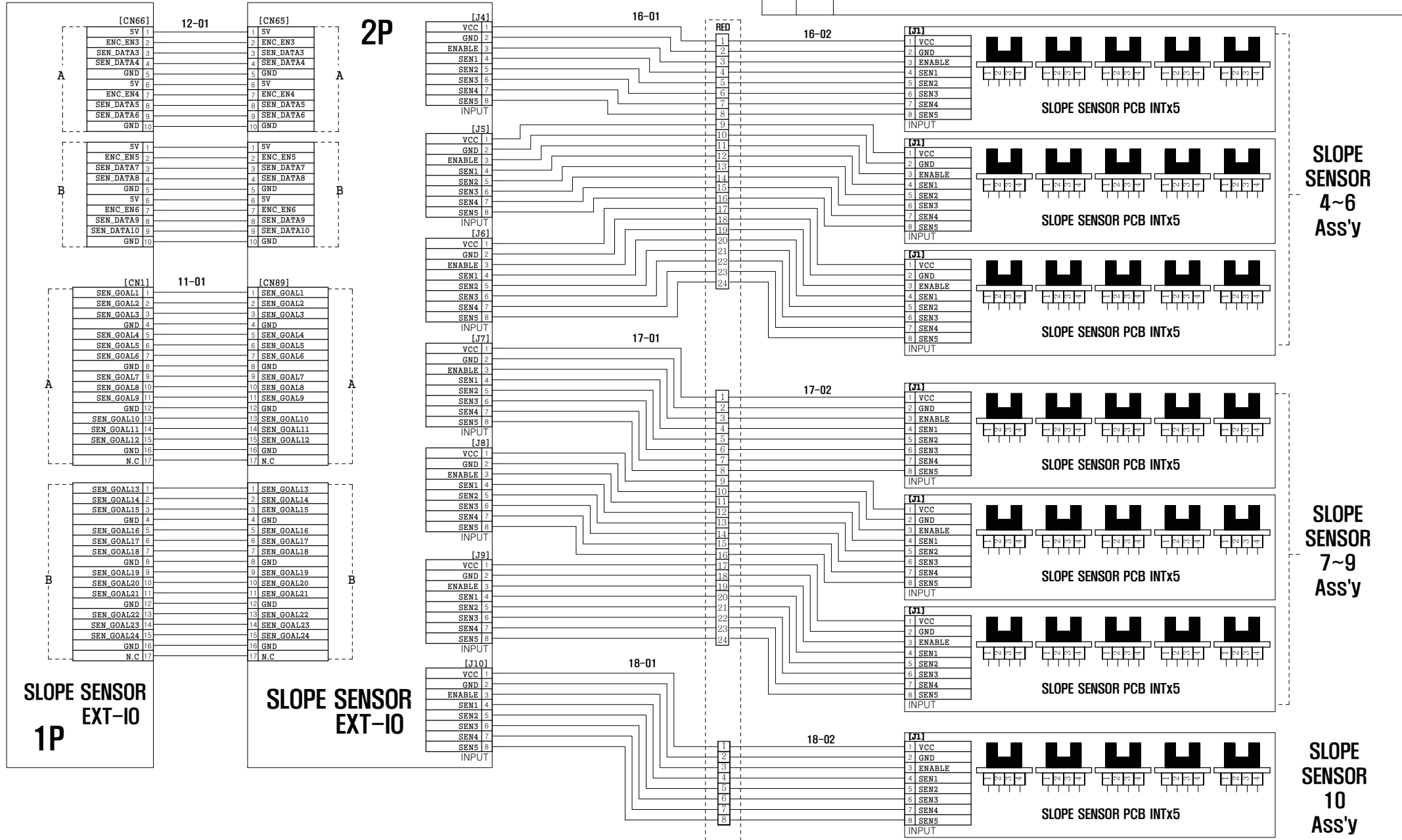

2P SLOPE SENSOR REAR PART

DRAWN BY	EXAMINATION	APPROVED BY	ITEM	JWFK
S.J.LEE			NAME	2P SLOPE SENSOR REAR PART
			DWG.NO	8 of 12
			CODE.NO	
			DATE	

ANDAMIRO

SLOPE LED Ass'y FRONT

MARK	DATE	REVISION

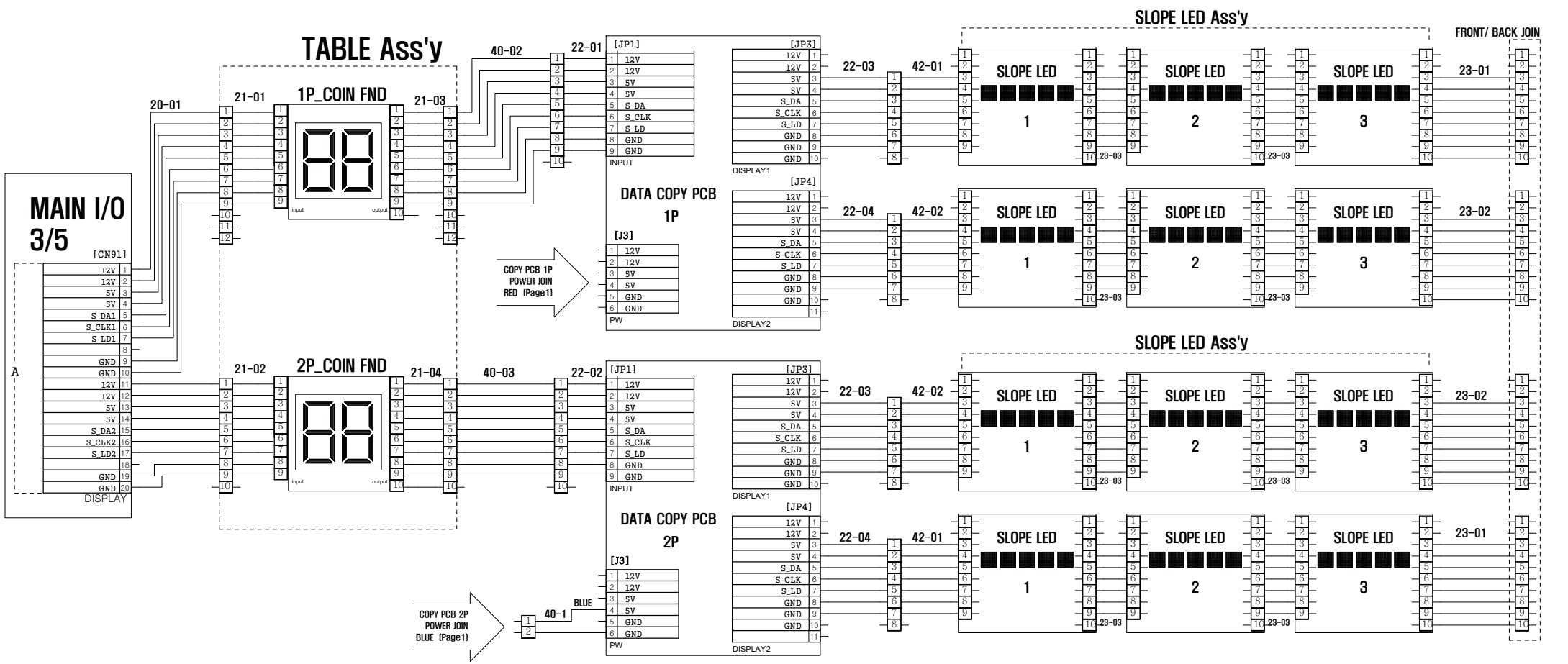

DRAWN BY	EXAMINATION	APPROVED BY	ITEM	JWFK
S.J.LEE			NAME	SLOPE LED FRONT SIDE
			DWG.NO	9 of 12
			CODE.NO	
			DATE	

ANDAMIRO

SLOPE LED Ass'y REAR PART

MARK	DATE	REVISION

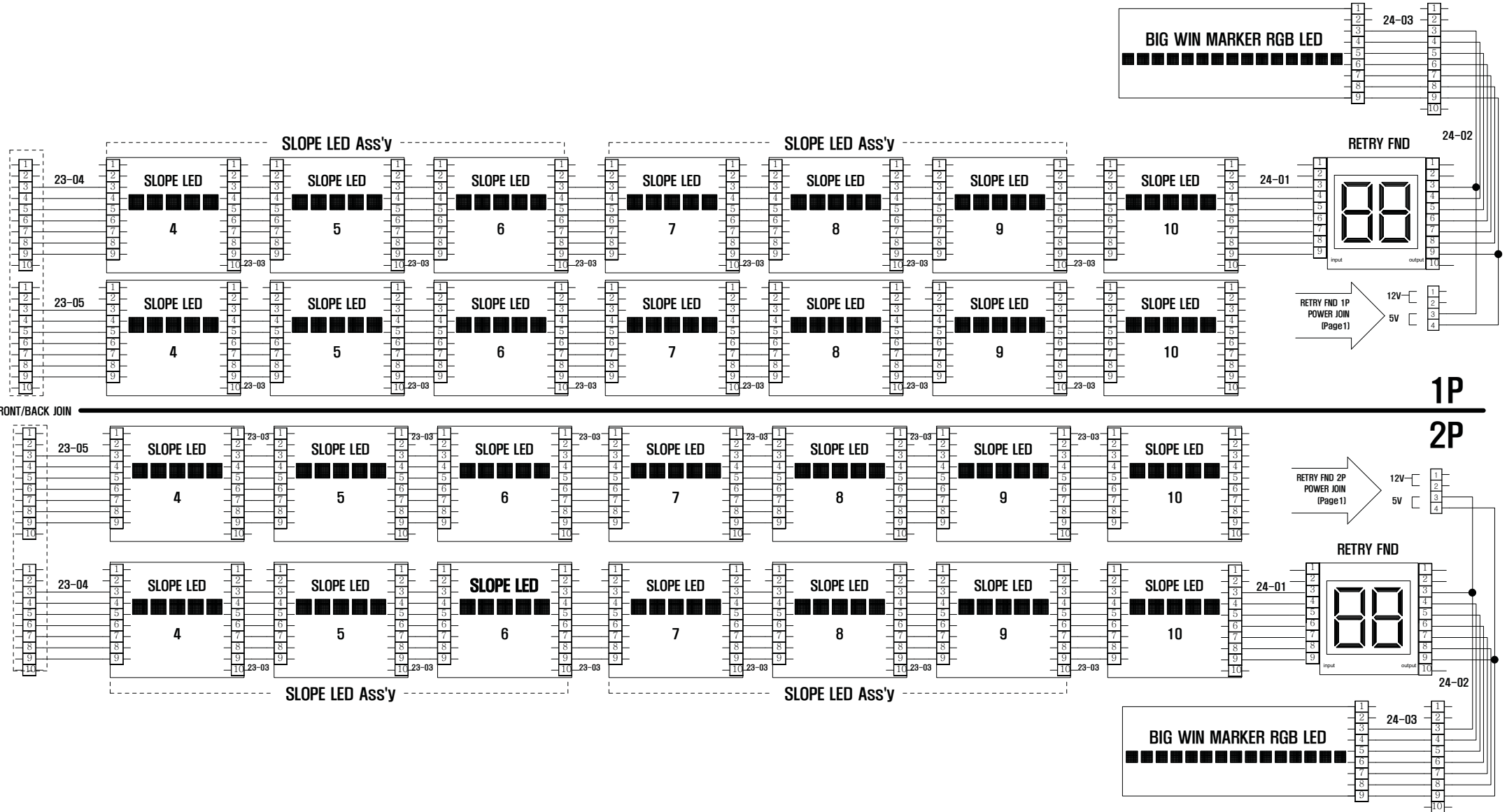

FRONT/BACK JOIN

DRAWN BY	EXAMINATION	APPROVED BY	ITEM	JWIE
S.J.LEE			NAME	SLOPE LED REAR PART
ANDAMIRO			DWG.NO	10 of 12
			CODE.NO	
			DATE	

MARK	DATE	REVISION

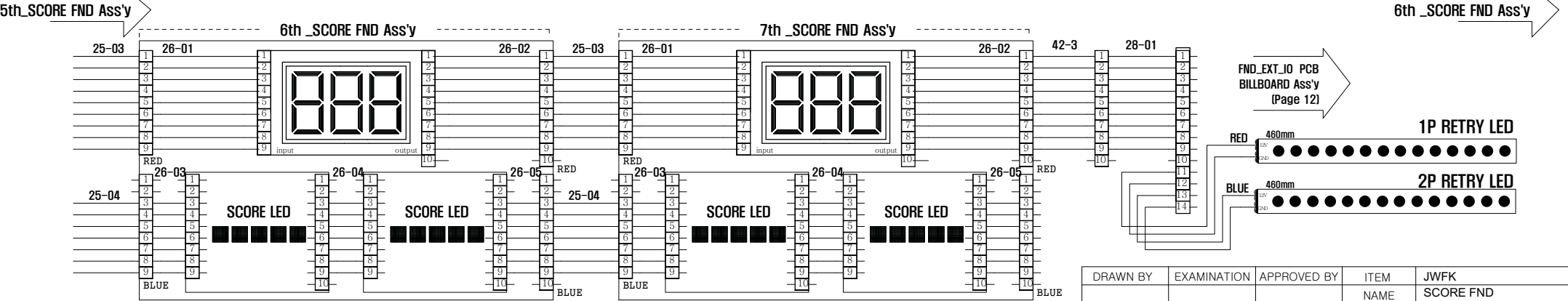
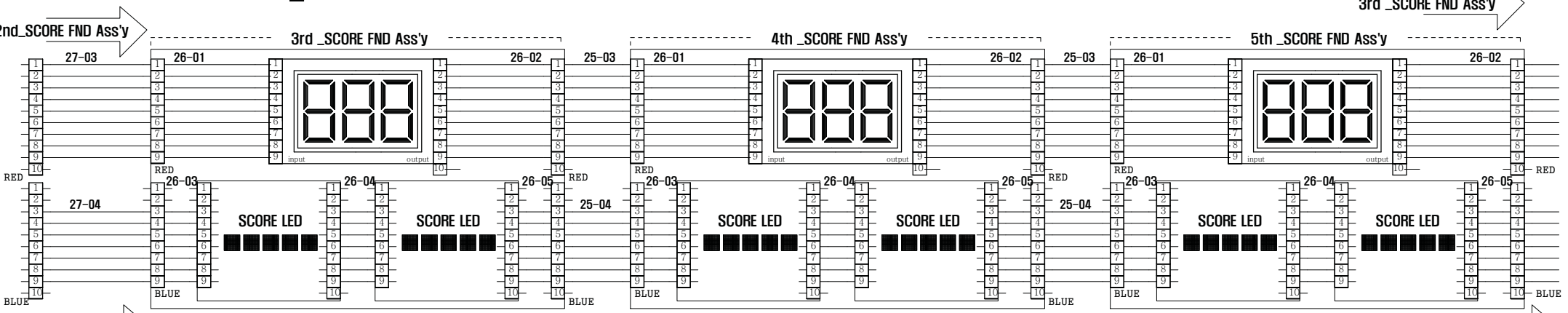
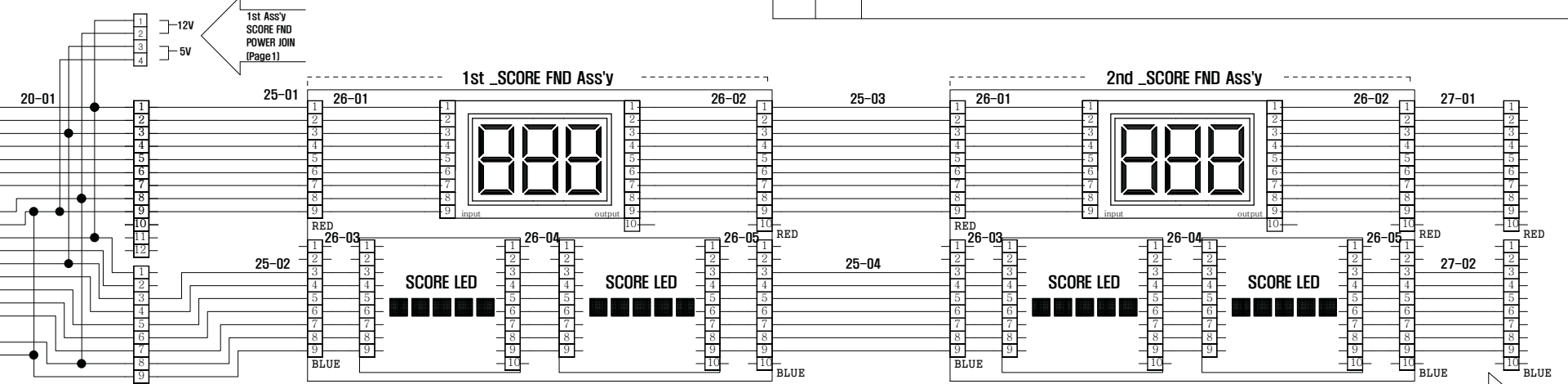
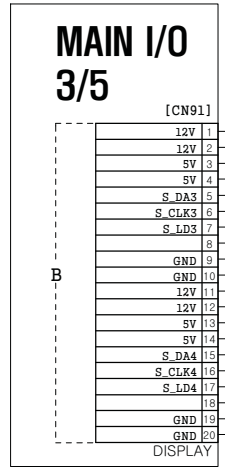

FND_EXT_IO PCB
BILLBOARD Ass'y
(Page 12)

DRAWN BY	EXAMINATION	APPROVED BY	ITEM	JWFK
S.J.LEE			NAME	SCORE FND
			DWG.NO	11 of 12
			CODE.NO	
			DATE	

ANDAMIRO

MARK	DATE	REVISION

BILLBOARD Ass'y

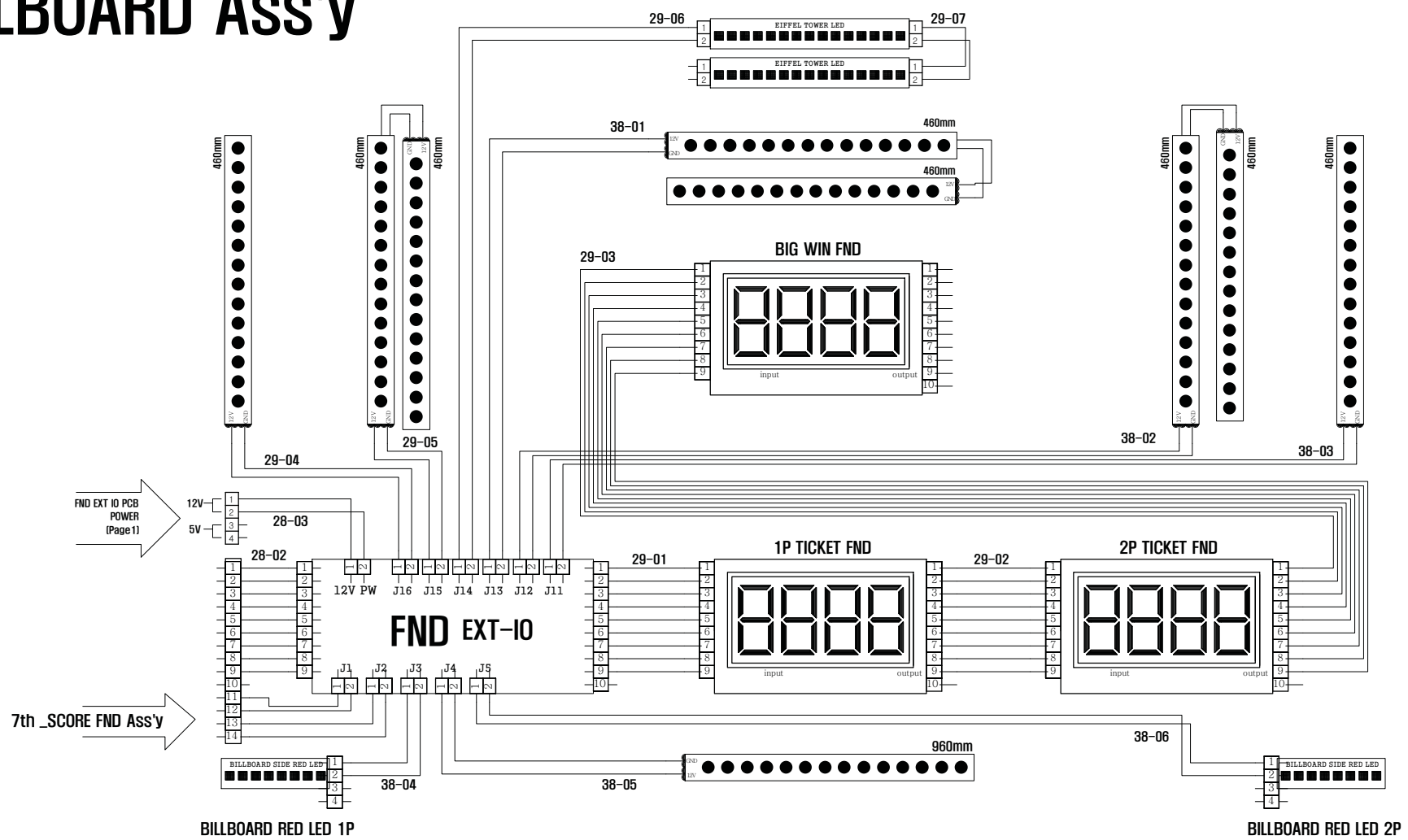

FND EXT IO PCB POWER (Page 1)

7th _SCORE FND Ass'y

DRAWN BY	EXAMINATION	APPROVED BY	ITEM	JWFK
S.J.LEE			NAME	BILLBOARD
			DWG.NO	12 of 12
ANDAMIRO			CODE.NO	
			DATE	



ANDAMIRO WARRANTY POLICY



Andamiro warrants to the original purchaser that all of its products will be free from defects in material and workmanship.

Andamiro warrants the parts from date of shipment as follows.

- **One Year Limited Warranty : Electronic Boards**
- **6 Months Limited Warranty : Moving Parts**

For any key components within the warranty period, Andamiro will repair or replace defective components free of charge.

When placing a warranty request, the customer is requested to furnish the following information:

1. Name of the game.
2. Serial Number of the game.
3. A Detailed Description of the defect/s experienced.

This warranty does not apply to the defects caused due to misuse or abuse of the product.

Any alterations made to game or game parts will void this warranty.

For warranty details on our product range please visit our website, www.andamiro.com.

ANDAMIRO CO., LTD.
www.andamiro.com





ANDAMIRO CO., LTD.
TEL : 82-31-909-2123~5

[ADDRESS OFFICE] 704-1 Techno Town, 138, Ilsan-ro, Ilsandong-gu, Goyang-si,
Gyeonggi-do, Republic of Korea 10442
[FACTORY] 72 Nochemgil, Ilsan-donggu Goyang-si, Gyonggi-do, 410-834 korea

USA BRANCH
ANDAMIRO USA CORP.
TEL : 1-310-767-5800

[ADDRESS] 2222 Century Cir, Irving TX 75062 U.S.A

Homepage <http://www.andamiro.com/>