



※IMPORTANT

- ▶ Please read the manual carefully and keep it in mind before using this machine.
- ▶ Put this manual within touch of your reference in anytime.

PRECAUTIONS FOR USE

The following safety precautions are given throughout this manual. They must be strictly followed to protect those who install, use or maintain this product as well as to protect players, visitors and property.

For safety reasons.

- The following suggestions should be adhered to:

WARNING

Disregarding could result in serious injury.

CAUTION

Disregarding could result in injury or product damage.

- The following graphic suggestions describe the types of precautions to be followed.



Indicates a care should be taken.



Forbidden.



Indicates a matter which must be performed.

- Precautions to be followed:

Certain procedures require a qualified in-shop maintenance person or industry specialist. For such instructions, a qualified person must take care of the jobs.

- Otherwise an electric shock, machine trouble, or a serious accident may result.
- Replacing the machine parts, inspecting and maintaining the machines, and troubleshooting must be assigned only to a qualified in-shop maintenance person or industry specialist. This booklet gives instructions that hazardous jobs in particular must be handled by an industry specialist. Qualified in-shop maintenance person and industry specialist are defined as follows.

Qualified in-shop maintenance person

- A service staff shall have experience in operations of game machines. The staff shall be responsible for assembly, installation, inspection and maintenance of the machine.

Industry specialist

- An industry specialist must be engaged in designing, manufacturing, inspecting and servicing amusement machines. He or she must have an education in electrical, electronic and mechanical engineering, and routinely maintain and repair amusement machines.

♣ PRECAUTIONS FOR USE

⚠ WARNING

Be sure to consult an industry specialist when setting up, moving or transporting this product.

- This product should not be set up, moved or transported by any one other than an industry specialist.
- When installing this product, set the 4 leg levelers evenly on the floor and make sure that the product is installed stably in a horizontal position. Unstable installation may result in injury or accident.
- When installing this product, do not apply undue force on movable parts. Otherwise, injury and accident may result, or the product may be damaged.

The machine for indoor usage only does not install outside.



Do not set the game machine up near emergency exits.



Protect the game machine from:

- Rain or moisture.
- Direct sunlight.
- Direct heat from air-conditioning and heating equipment, etc..
- Hazardous flammable substances.
- Otherwise an accident or malfunction may result.



Do not place containers holding chemicals or water on or near the game machine.



Do not place objects near the ventilating holes.



Do not bend the power cord by force or place heavy objects on it.



Never plug or unplug the power cord with wet hands.



Never unplug the game machine by pulling the power cord.



⚠ CAUTION

Be sure to use indoor wiring within the specified voltage requirements. For extension cord, use the specified rating or more.

Be sure to use the attached power cord.

Never plug more than one cord at a time into the electrical receptacle.



Do not lay the power cord where people walk through.



Be sure to ground this product.



Do not exert excessive force when moving the machine.



For proper ventilation, keep the game machine 100mm(4") away from the walls.

Do not alter the system related dipswitch settings.

♣ PRECAUTIONS FOR USE

⚠ WARNING

If there is any abnormality such as smoke, bad smell or abnormal noise being emitted from the machine, immediately turn OFF the main power switch and unplug the power cord from the receptacle to stop operating it. 

- Using the machine in abnormal conditions could result in fire or accidents.

In case of abnormality

1. Turn OFF the main power switch.
2. Unplug the power cord from the receptacle.
3. Contact your nearest dealer.

Do not leave the power cord plugged in improperly or covered with dust. 

- Doing so could result the power cord periodically.

⚠ CAUTION

Do not use this product anywhere other than industrial areas. 

- Using in a residential area or an area next to a residential area could affect signal reception of radios, television sets, telephones, etc..

- Do not give shock the surface of glass products.

- Please do not play this game if
 - When you do drinking;
 - When your physical condition is not normal;
 - When you are in pregnancy;
 - When you have on a pulse controller;
 - When you have recently experienced a cramp or fainting away while watching TV.
- Avoid excessive force/shock while playing/moving the game.
- While do games, pay attention to surrounding.

Do not plug or unplug the power cord with wet hands. 

In handling the power cord, follow the instructions below. 

- | | |
|---|--|
| • Do not damage the power cord. | • Do not modify the power cord. |
| • Do not bend the power cord excessively. | • Do not twist the power cord. |
| • Do not heat the power cord. | • Do not pull the power cord. |
| • Do not bind the power cord. | • Do not stand on the power cord. |
| • Do not sandwich the power cord. | • Do not drive a nail into the power cord. |

If the power cord or power plug becomes damaged, stop using the machine immediately and ask your nearest dealer to replace the parts.

♣ PRECAUTIONS FOR USE

⚠ WARNING

Be sure to turn OFF the main power switch and unplug the power cord from the receptacle before inspecting or cleaning the machine. 

When replacing parts, be sure to use parts of the correct specifications. Never use parts other than the specified ones. 

Opening inside the machine shall be done by machine specialist only as high electric current is being sent inside. For game machine with monitor, a care should be taken while opening its back door. If not, a damage to the inside parts or the monitor may occur. 

If the sub power switch of the service panel is turned OFF without turning OFF the main power switch of the power supply unit, some parts in the units remain live. When opening the back door, be sure to turn OFF the main power switch and unplug the power cord from the receptacle. 

Strictly refrain from disassembly and repair of parts which are not indicated in this manual, as well as settings and remodeling. 

To clean the game machine, wipe it with a soft cloth dampened in a neutral detergent.

- Using thinner or other organic solvent or alcohol may decompose the material.
- Electrical shock or equipment failure could be caused by water entering the inside of the machine.

⚠ CAUTION

Components in the game are sensitive to vibrations and impact. Care should be used when moving and transporting the game machine. 

Be sure not to let the machine tip over.

Before moving the machine, be sure to turn OFF the main power switch, unplug the power cord from the receptacle and remove the power cord from the machine. 

Before moving take the machine, off the levelers and move it on the casters.

Avoid excessive force while moving the machine.

.....

PRECAUTIONS IN HANDLING

- When setting up, inspecting, maintaining, moving or transporting this product, follow the procedures and instructions set forth in this manual and perform such work safely.
- Do not set up, handle, inspect, maintain, move or transport this product under conditions equivalent to the condition of "WARNING" or "CAUTION" specified in this manual.
- If a new owner is to have this product as a result of transfer, etc., be sure to give this manual to the new owner.

* CONTENTS

1. SPECIFICATION AND DIMENSIONS	8-5. MIDDLE BILLBOARD BOX ASSY
1-1. DIMENSIONS	8-6.ASSEMBLING COIN FND ASSY
1-2. SPECIFICATION	8-7.ASSEMBLINGPOWER SWITCH SETUP ASSY
2. NAME OF PARTS & STICKER LOCATION	8-8.ASSEMBLING FIRE LIGHT ASSY
2-1. NAME OF PARTS	8-9.ASSEMBLING 3 WAVES LAMP
2-2. STICKER LOCATION	8-10.ASSEMBLING MAIN PCB PW ASSY
3. COMPONENTS	8-11.ASSEMBLING COIN BOX ASSY
4. HOW TO ASSEMBLE	8-12.ASSEMBLING AC INPUT BRACKET
4-1. HOW TO ASSEMBLE	8-13.ASSEMBLING POWER MDF PANNEL
5. SETUP MODE, CLEAR MODE, ERROR NO	8-14.ASSEMBLING 4 JACKPOT FND
5-1. INNITIAL STAGE OF SETUP MODE	8-15.ASSEMBLING HEAD LIGHT
5-2. INNITIAL STAGE OF CLEAR MODE	8-16.ASSEMBLING MASK SIDE LIGHT
5-3. INNITIAL STAGE OF ERROR NO	8-18.ASSEMBLING TRAIN MASK VACUUM ELECTRONIC
6. TEST MODE	8-19.ASSEMBLING TRAIN MASK VACUUM REAR BOX
6-1. INNITIAL STAGE OF TEST	8-20.ASSEMBLING MOTOR PULLEY
6-2. SENSOR AND SWITCH TEST	8-21.ASSEMBLING WHEEL MAIN SHAFT
NAME OF PARTS (WHEEL ASSY)	8-22.ASSEMBLING MAIN WHEEL
7. TROUBLESHOOTING	8-23.ASSEMBLING WHEEL BASE
7-1. ERROR CODE [04]	8-24.ASSEMBLING WHEEL BASE ASSY 173
7-2. ERROR CODE [01,02,03]	8-25.ASSEMBLING THIRD ABOARD
8. ASSEMBLING	8-26.ASSEMBLING SIDE LIGHT ACRYL
8-1.ASSEMBLING COIN SEL MAIN ASSY	8-27.ASSEMBLING MIDDLE LIGHT ACRYL
8-2.ASSEMBLING TICKET DISPENSOR ASSY	8-28.ASSEMBLING SIDE MIDDLE ACRYL LIGHT
8-3.BUTTON LIGHT BACK COVER ASSY	8-29.ASSEMBLING MAIN CABINET
8-4. FRESNEL BUTTON ASSY	8-30.ASSEMBLING MAIN CABINET ELEC
	8-31.ASSEMBLING ALL ABOARD
	9. ALL ABOARD WIRE DIAGRAM
	10. ALL ABOARD SHEET

1. SPECIFICATION AND DIMENSIONS

1-1. DIMENSIONS

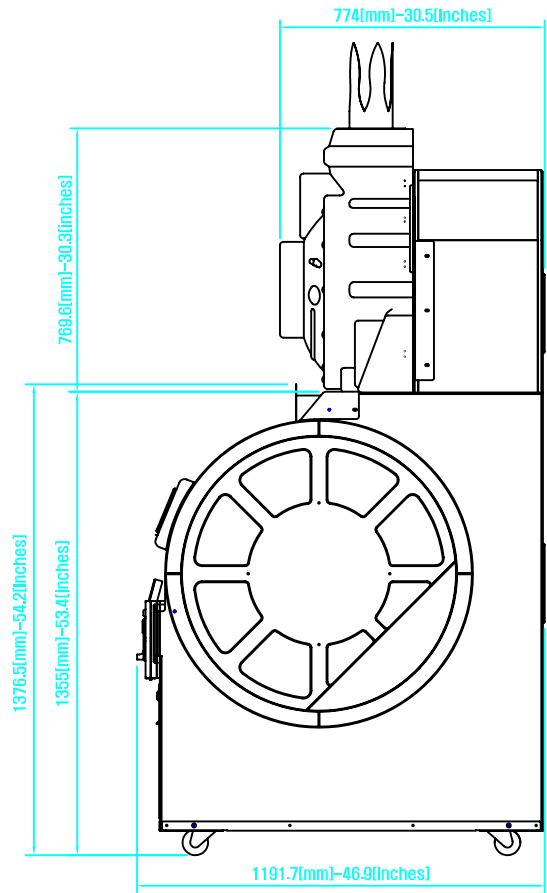
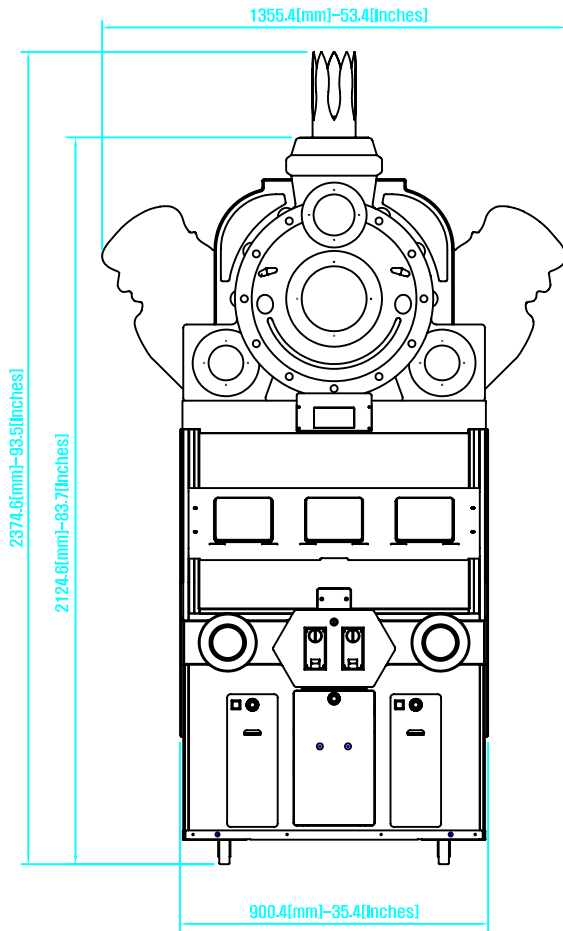

1-2. SPECIFICATION

NOMINATED VOLTAGE RANGE	AC 120V/220V
NOMINATED FREQUENCY RANGE	50Hz ~ 60Hz
POWER CONSUMPTION	230W
WEIGHT	222Kg(489Lb)

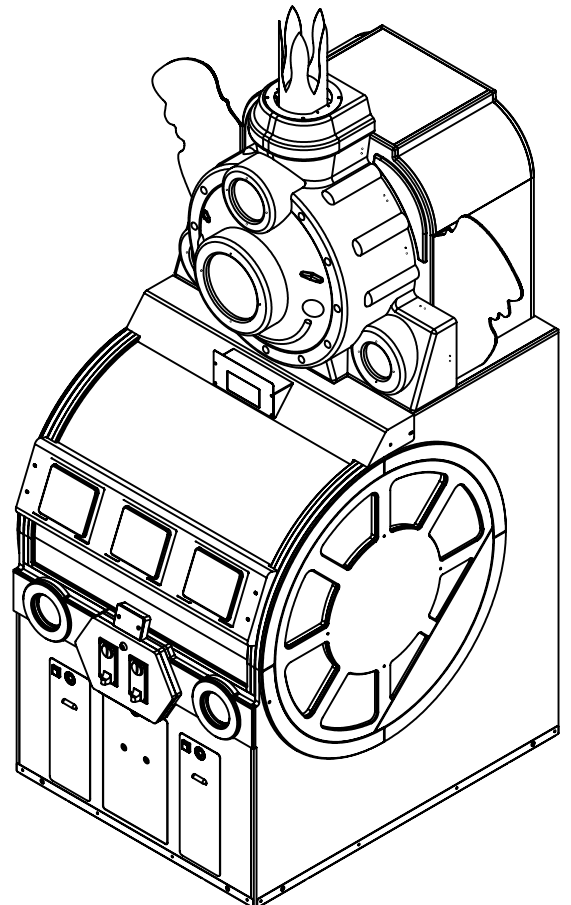

2. NAME OF PARTS & STICKER LOCATION

2-1. NAME OF PARTS

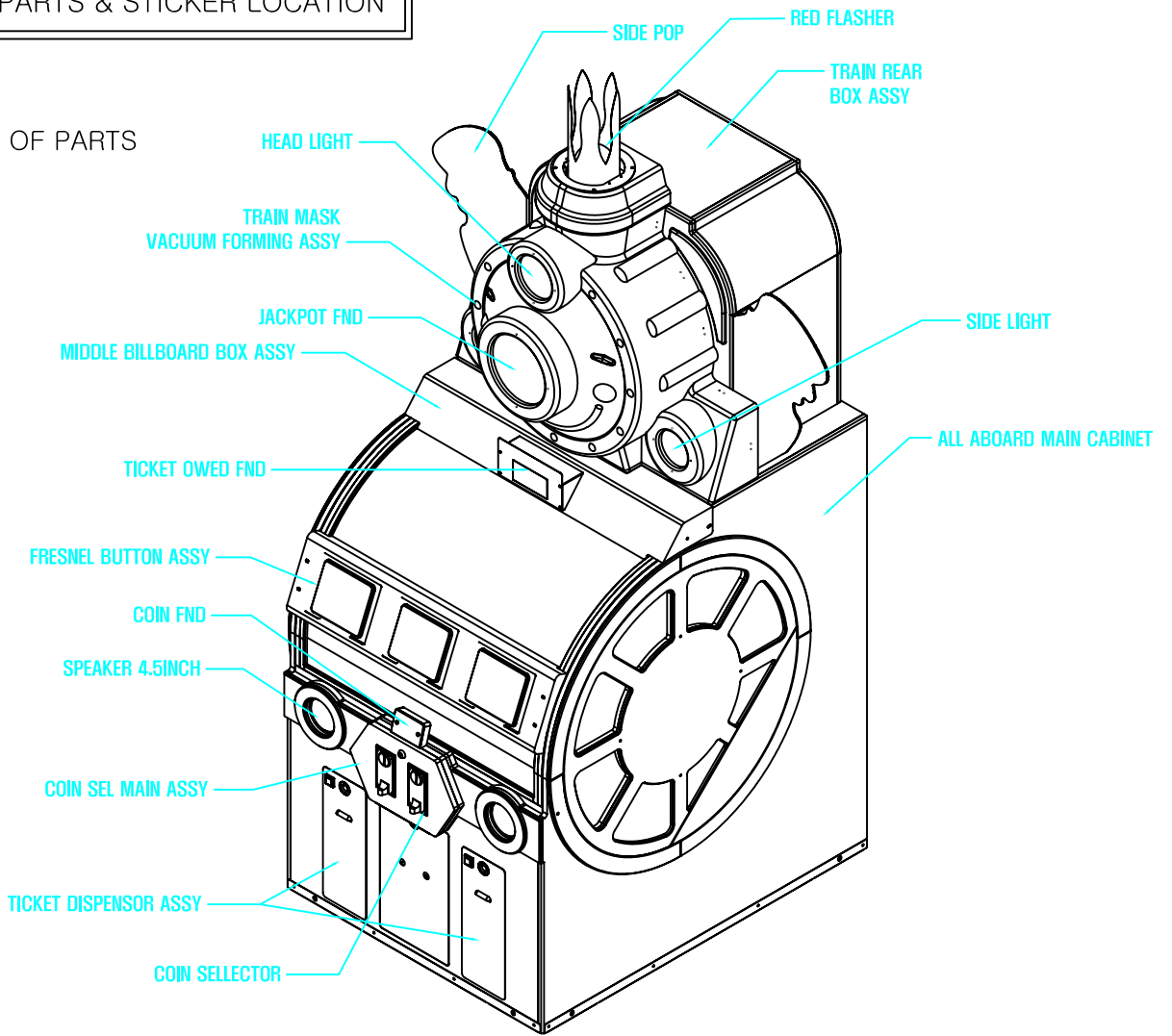

2-2. STICKER LOCATION

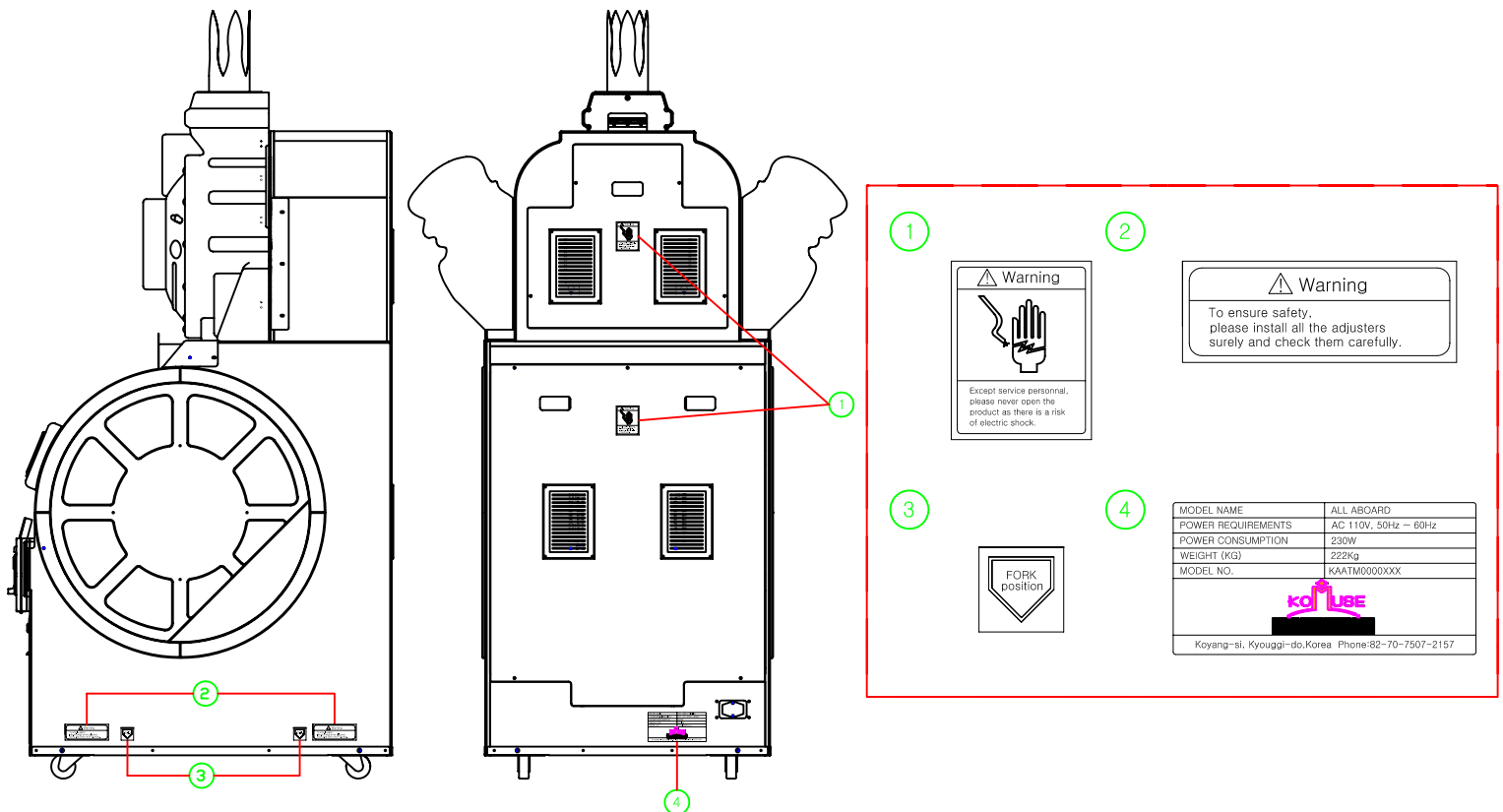

3. COMPONENTS

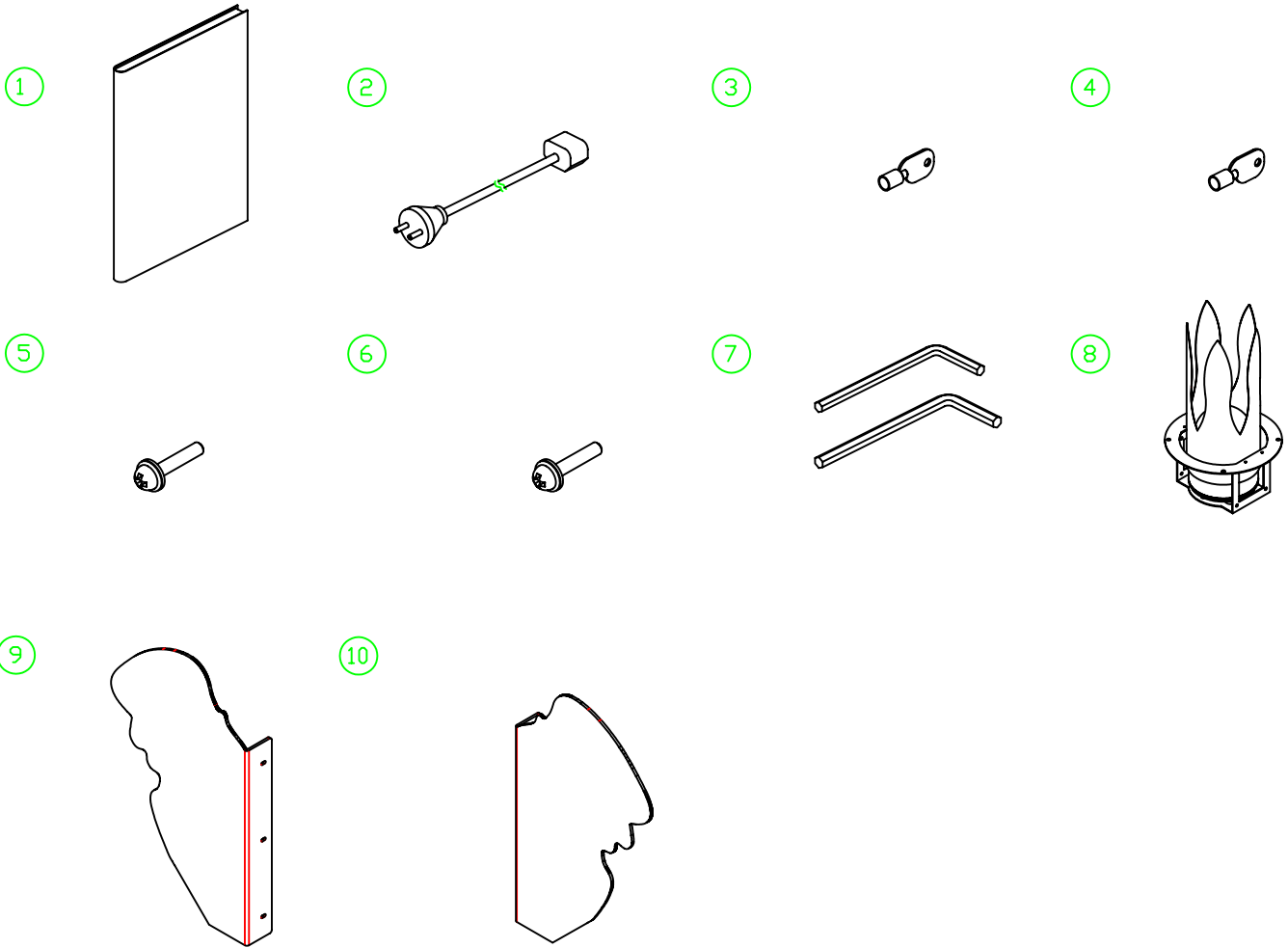

NO.	PART NAME	SPEC.	QUANTITY	CODE NO.
1	MANUAL	MANUAL	1	-
2	AC POWER CORD		1	-
3	FRONT DOOR, TOP DOOR, TICKET DOOR KEY	7001	2	-
4	MONEY BOX KEY	6001	2	-
5	BOLT	M4x15L	4	
6	BOLT	M4x25L	6	-
7	WRENCH	3mm, 4mm	1ea, 1ea	-
8	FIRE LIGHT ASSY	RED FLASHER	1ea	-
9	SIDE POP L		1ea	-
10	SIDE POP R		1ea	-

4-1. HOW TO ASSEMBLE

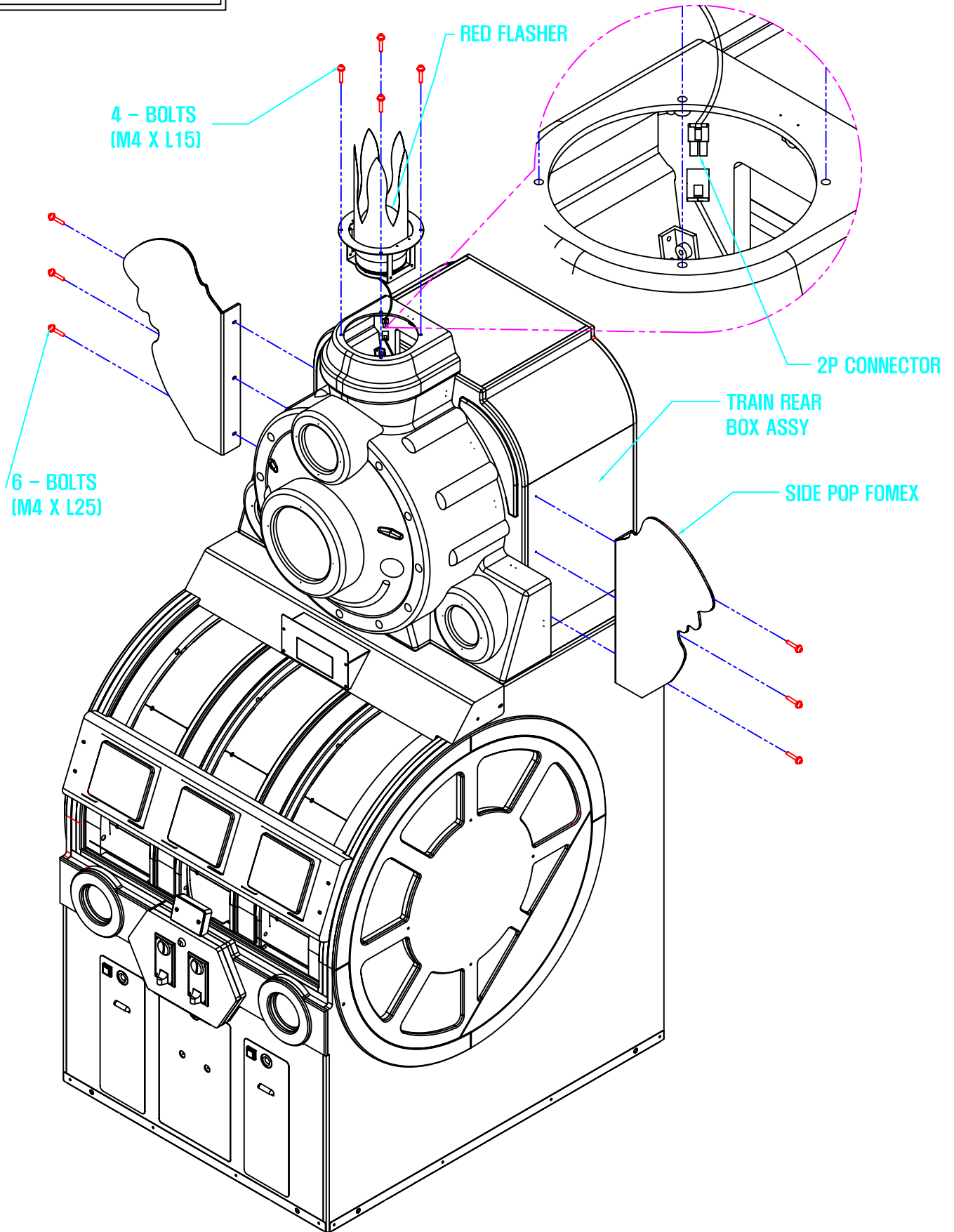

1. Connect the RED FLASHER(2P) Harness as shown above.
2. Assemble the RED FLASHER with enclosed bolts(M4 x 15L) to the TRAIN MASK VACUUM FORMING ASSY.
3. Assemble the SIDE POP FOMEX with enclosed bolts(M4 x 25L) to the TRAIN REAR BOX ASSY.

* SETUP MODE DISPLAY

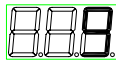

* PATTERN MENU DISPLAYS IN CASE WHEEL PATTERN NO. "9" IS SELECTED.
("9" MEANS THE HAIRY GRANDFA'S VALUE)

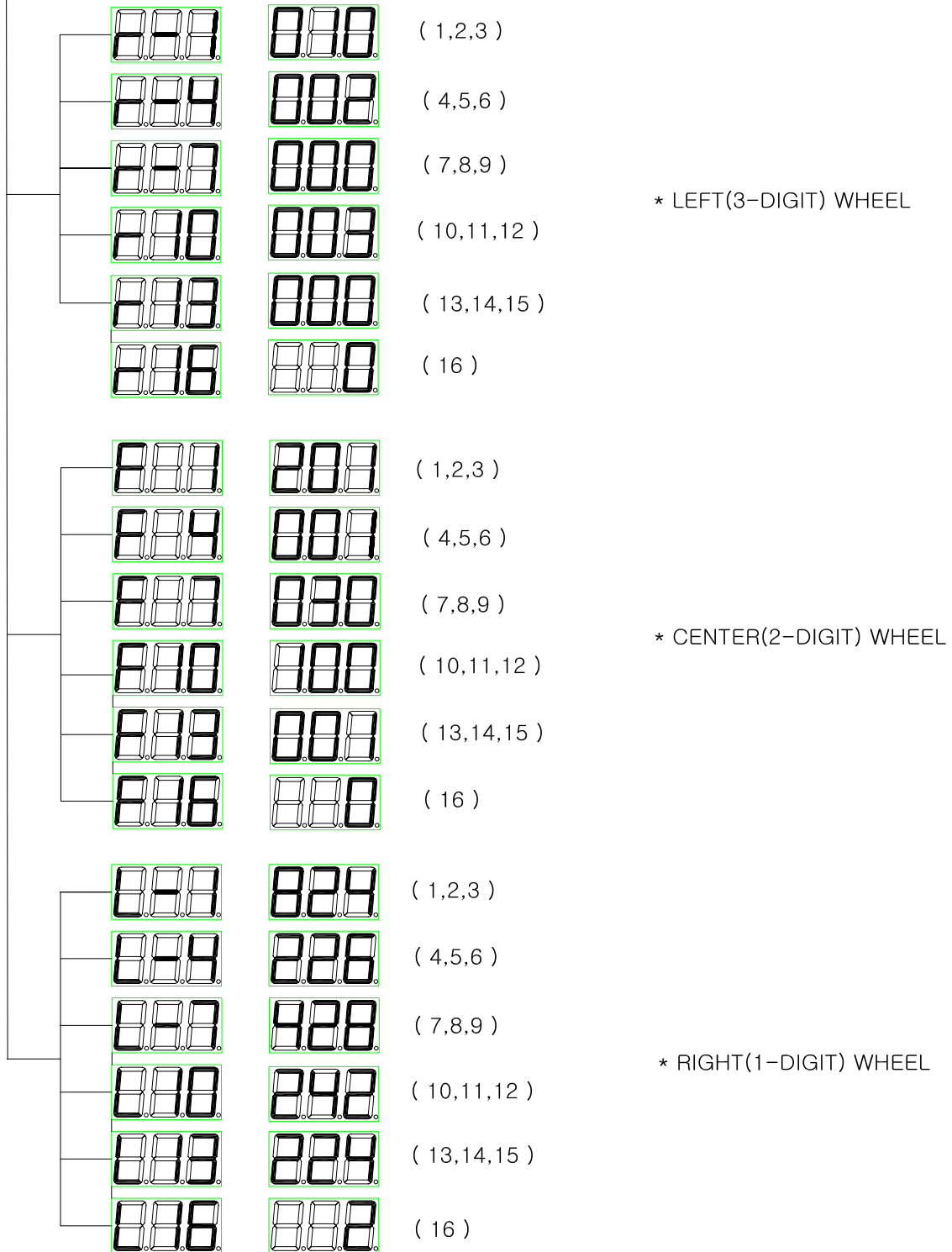

5-2. INITIAL STAGE OF CLEAR MODE

- ENTER INTO CLEAR MODE BY TURNING ON THE MACHINE WITH SW3(ENTER) BUTTON PUSHED.
- CHANGE THE SETTING VALUE OF CLEAR MODE BY PUSHING SW2(SEVICE) BUTTON.
- CLEAR THE DATA BY PUSHING SW3(ENTER) BUTTON.
- * RETURN TO GAME STATUS BY PUSHING SW1(SETUP) BUTTON.

* Clear Mode

JACKPOT Fnd

OWED Fnd

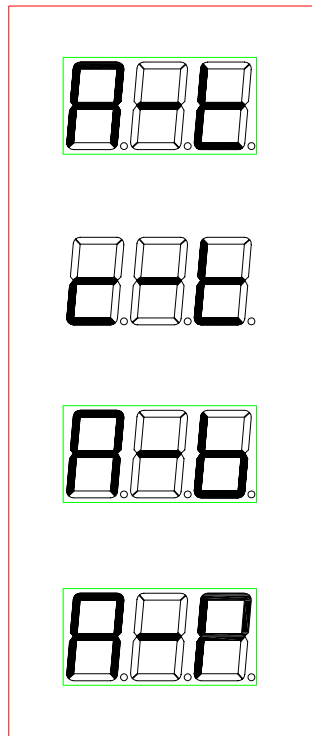
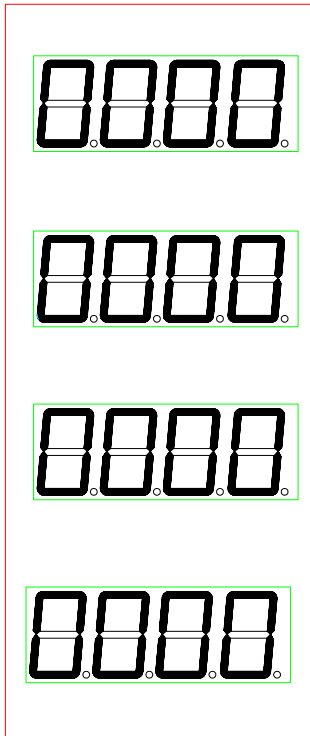

—— *THE NO. OF DISPENSED TICKETS IS INITIALIZED.
; Push SW3 button to clear the number

—— *THE NO. OF ACCUMULATED COINS ON CREDIT FND IS INITIALIZED.
; Push SW3 button to finish the clear mode

—— * INITIAL VALE OF PROBABILITY
; Push SW3 button to finish the clear mode

—— * FACTORY-SET VALUE

5-3. Error mode

OWEND FND

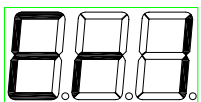

—— RIGHT(1-DIGIT) ER1 DISPLAYS WHEN RIGHT(1-DIGIT)WHEEL MOTOR DOESN'T WORK OR SENSOR HAS PROBLEMS.

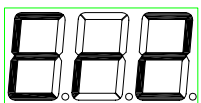

—— CENTER(2-DIGIT)ER2 DISPLAYS WHEN CENTER(2-DIGIT)WHEEL MOTOR DOESN'T WORK OR SENSOR HAS PROBLEM.

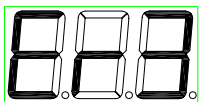

—— LEFT(3-DIGIT) ER3 DISPLAYS WHEN LEFT(3-DIGIT)WHEEL MOTOR DOESN'T WORK OR SENSOR HAS PROBLEMS.

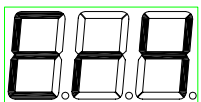

—— ER4 DISPLAYS WHEN TICKET MOTOR DOESN'T WORK OR SENSOR HAS PROBLEMS OR NO TICKET.

6. TEST MODE

6-1. INITIAL STAGE OF TEST MODE

- ENTER INTO "TEST MODE" BY PUSHING SW3(ENTER) BUTTON FOR ABOUT 3 SECONDS.
- CHANGE MODE BY PUSHING SW2(SERVICE).
- CHANGE SETTING VALUE BY PUSHING SW1(SETUP).

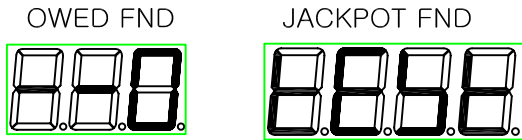

INITIAL STATUS OF WHEEL TEST MODE

NO.	SETUP FND	REFERENCE	NO.	SETUP FND	REFERENCE
1		LEFT(3-DIGIT) WHEEL MOTOR OFF	9		LED & FND TEST OFF
2		LEFT(3-DIGIT) WHEEL MOTOR ON	10		LED & FND TEST AUTO ON
3		CENTER(2-DIGIT) WHEEL MOTOR OFF	11		LEFT TICKET MOTOR TEST OFF
4		CENTER(2-DIGIT) WHEEL MOTOR ON	12		LEFT TICKET MOTOR TEST ON
5		RIGHT(1-DIGIT) WHEEL MOTOR OFF	13		RIGHT TICKET MOTOR TEST OFF
6		RIGHT(1-DIGIT) WHEEL MOTOR ON	14		RIGHT TICKET MOTOR TEST ON
7		TICKET COUNTER ON	15		SOUND TEST OFF
8		COIN COUNTER ON	16		SOUND TEST ON

YOU CAN HEAR SOUND WHEN SW2(SERVICE) IS PUSHED.

TICKET OWED











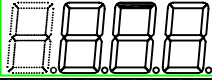
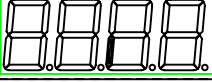





TICKET OWED : DISPLAY FIGURES UNDER WHEEL TEST MODE 1~3 (POINT FIGURES).

- (1-DIGIT) RIGHT WHEEL NO. DISPLAY
- (2-DIGIT) CENTER WHEEL NO. DISPLAY
- (3-DIGIT) LEFT WHEEL NO. DISPLAY

6-2. SENSOR AND SWITCH TEST

- JACKPOT FND DISPLAYS FIGURES AS FOLLOWS WHEN SENSOR/SWICH IS SENSED.

NO.	내용	JACKPOT FND
1	ticket dispenser sensor 1 Sensing (LEFT ticket dispenser)	
2	ticket empty swich 1 Sensing (LEFT ticket dispenser)	
3	ticket dispenser sensor 2 Sensing (RIGHT ticket dispenser)	
4	ticket empty swich 2 Sensing (RIGHT ticket dispenser)	
5	LEFT(3-digit) wheel encoder sensor Sensing	
6	CENTER(2-digit) wheel encoder sensor Sensing	
7	RIGHT(1-digit) wheel encoder sensor Sensing	
8	LEFT(3-digit) wheel position sensor Sensing	
9	CENTER(2-digit) wheel position sensor Sensing	
10	RIGHT(1-digit) wheel position sensor Sensing	
11	coin 1 swich Sensing	
12	coin 2 swich Sensing	
13	RIGHT(1-digit) wheel button swich Sensing	
14	CENTER(2-digit) wheel button swich Sensing	
15	LEFT(1-digit) wheel button swich Sensing	

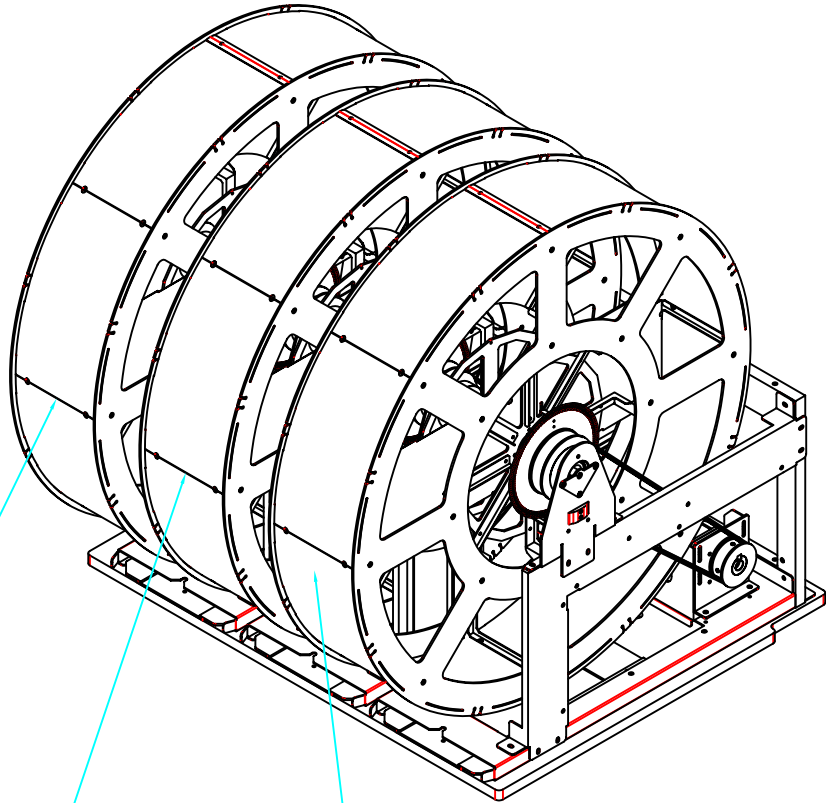

LEFT WHEEL ASSY
(3 DIGIT)

CENTER WHEEL ASSY
(2 DIGIT)

RIGHT WHEEL ASSY
(1 DIGIT)

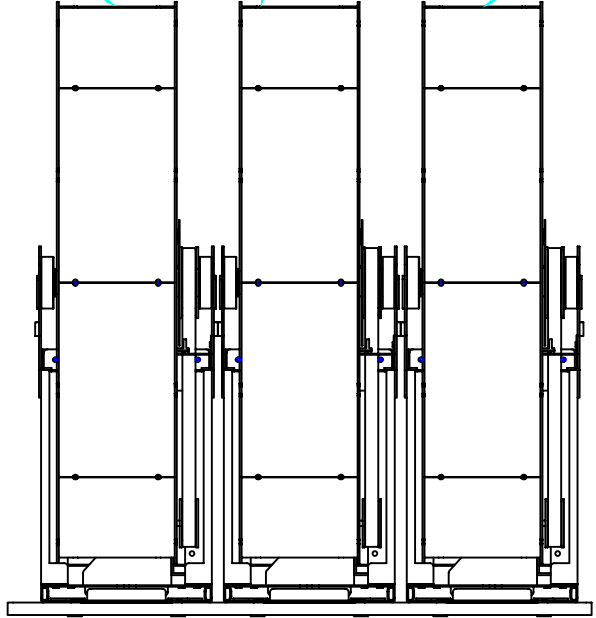

7. TROUBLESHOOTING

7-1. Error Code "4"

#WHEN TICKET DISPENSOR DOESN'T WORK OR TICKET IS EMPTY.

- TEST ACCORDING TO TEST MODE 7-1,8-1
- CONFIRM THE STATUS OF MOTOR AFTER TESTING.

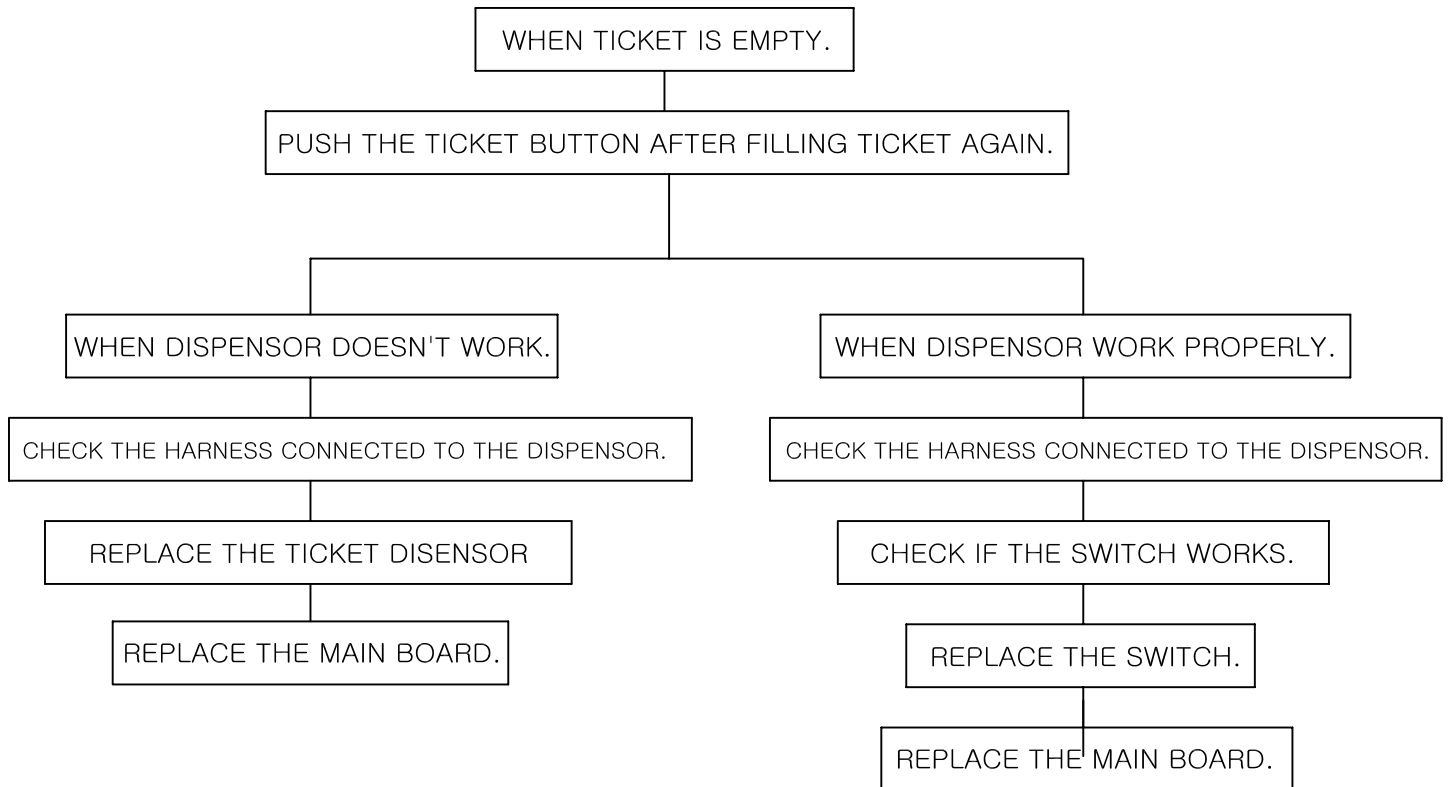

TICKET EMPTY BUTTON

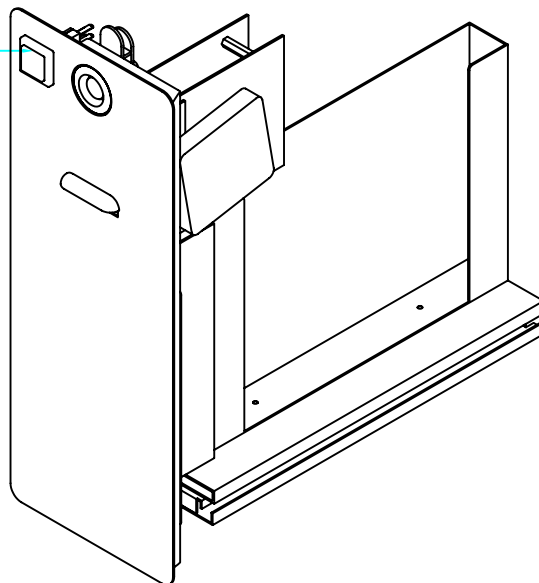

Reference A: TICKET DISPENSOR ASSY

7-2. <Error code "1,2,3">

#WHEN WHEEL MOTOR OR ENCODER SENSOR DOESN'T WORK, "ERROR CODE 1,2,3" IS SHOWING..

-TEST ACCORDING TO TEST MODE 1-1,2-1,3-1

ERROR 1 - (1 DIGIT)

ERROR 2 - (2 DIGIT)

ERROR 3 - (3 DIGIT)

WHEN WHEEL MOTOR DOESN'T WORK.

CHECK THE HARNESS CONNECTED TO THE MOTOR

CHECK IF ANY BOLTS ON THE MOTOR ARE LOOSEN.

REPLACE THE MOTOR.

REPLACE THE MAIN BOARD.

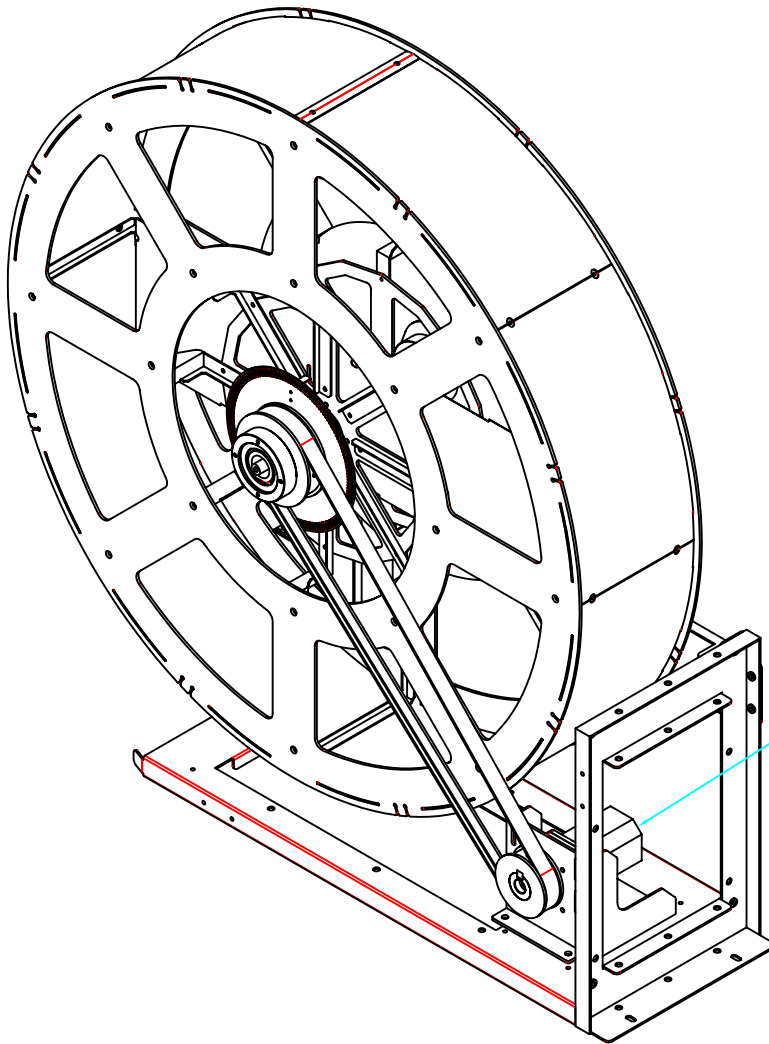

2. MOTOR -K6DG6N1
(DC12V-6W)
GEAR HEAD-K6G75C
(K6G-1:075)

Reference B: WHEEL ASSY

WHEN WHEEL MOTOR WORKS PROPERLY.

CHECK IF PHOTO SENSOR PCB WORKS PROPERLY.

REPLACE THE PHOTO SENSOR PCB.

REPLACE THE MAIN BOARD.

→ CHECK ACCORDING TO NO.1-1,2-1,3-1 IN TEST MODE

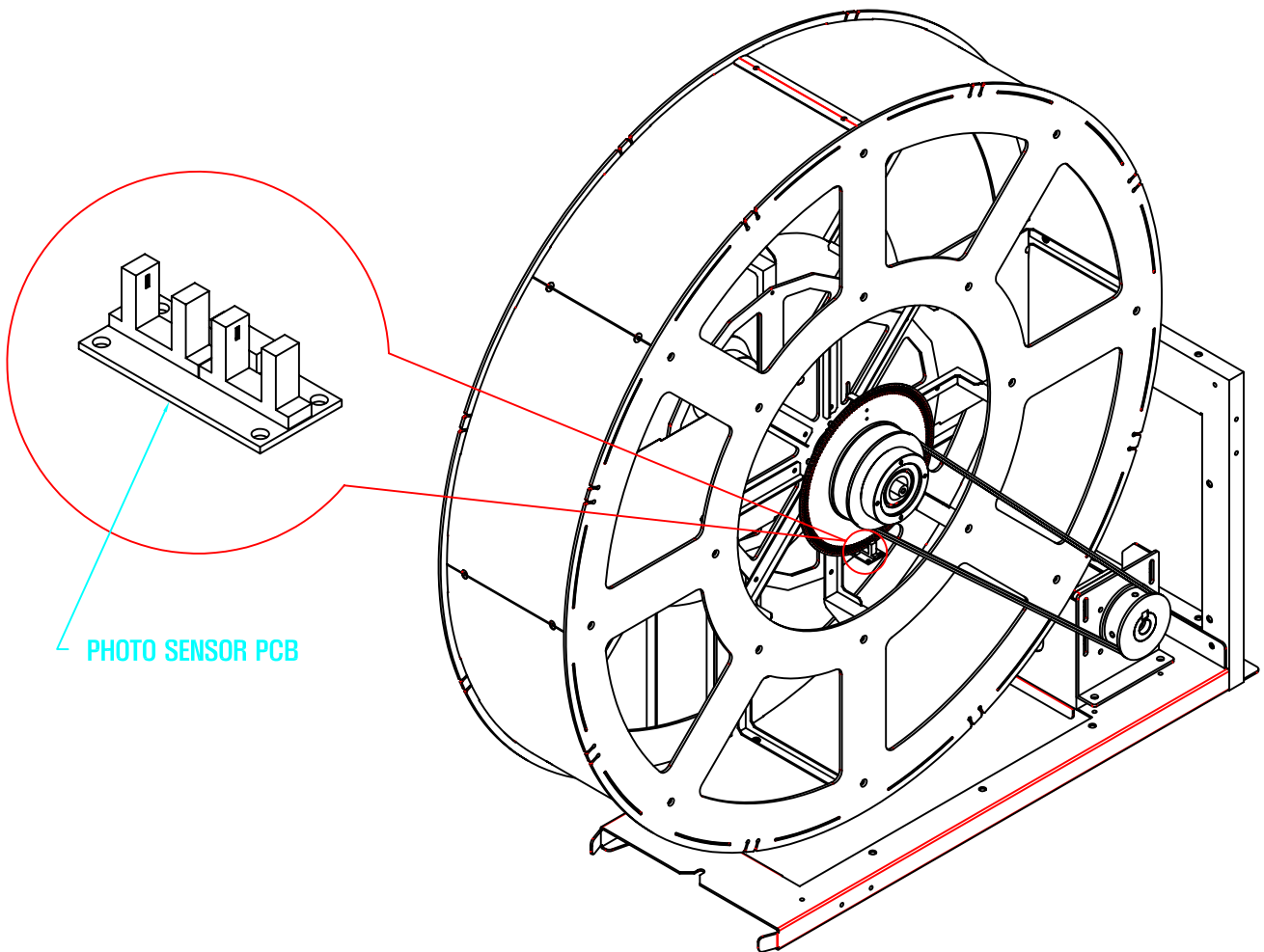

Reference C: WHEEL ASSY

8. ASSEMBLING

8-1.ASSEMBLING COIN SEL MAIN ASSY

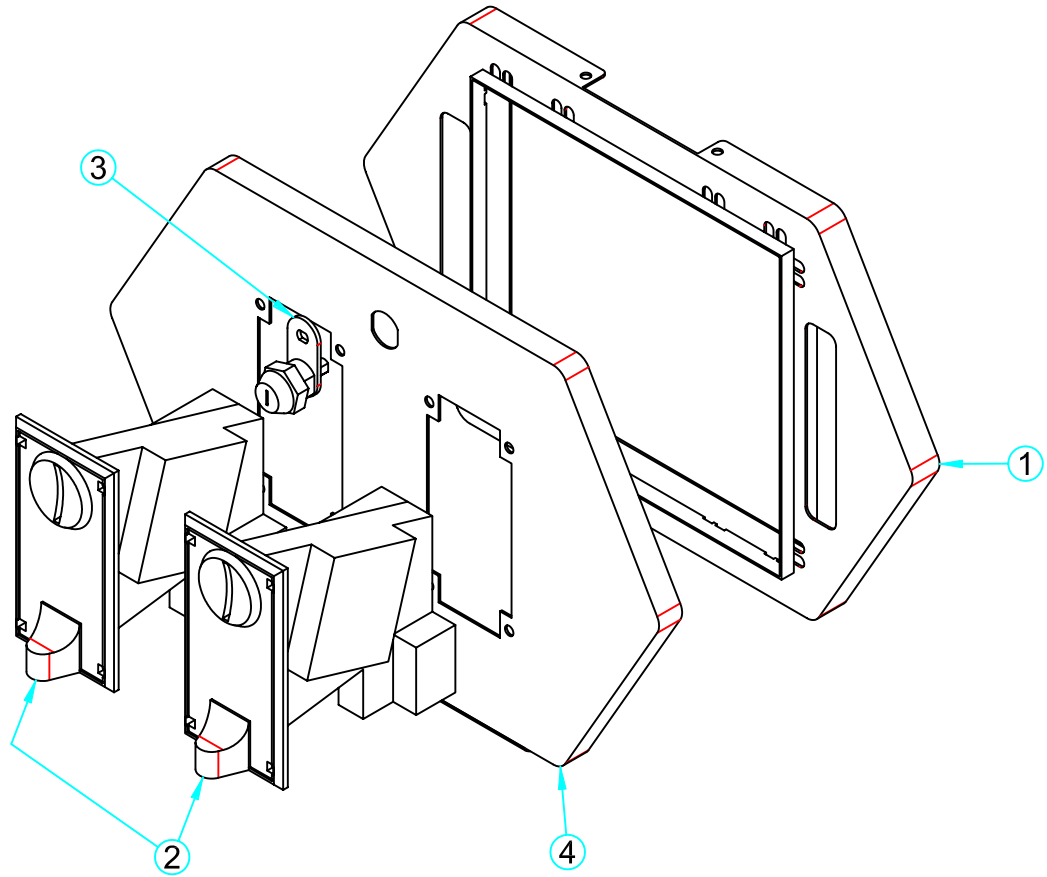

NO.	PART NAME	SPEC.	QUANTITY	CODE NO.
1	COIN SEL MAIN BACK	-	1	MALA0MEP048
2	COIN SELECTOR	SG-628	2	MZZZ0COS013
3	KEY ASS'Y	7001	1	MZZZ0KEY032
4	COIN SEL MAIN SUPPORT ASSY	-	1	MALA0MEP005

8-2.ASSEMBLING TICKET DISPENSOR ASSY

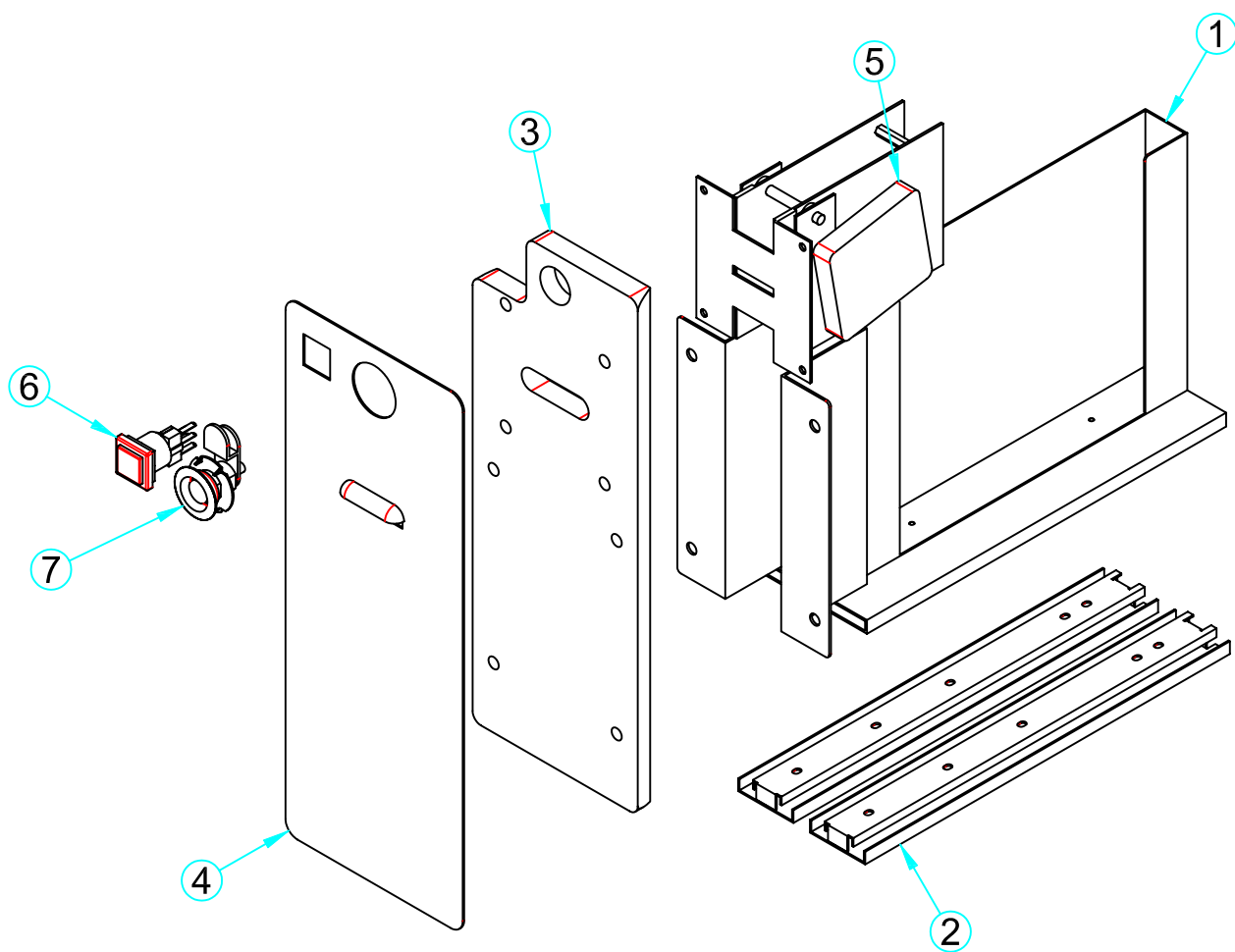

NO.	PART NAME	SPEC.	QUANTITY	CODE NO.
1	TICKET BOX ASSY	-	1	MALA0MEP007
2	LINEAR(GUIDE RAIL)	300mm	2	-
3	ticket door	-	1	MALA0WOO008
4	ticket door cover	-	1	MALA0MEP035
5	TICKET DISPENSOR	CLECO	1	MZZZ0TID003
6	BUTTON	AM1PB-26SH-R12D	1	MHA20000007
7	KEY ASSY	7001	1	MZZZ0KEY032

8-3.ASSEMBLING BUTTON LIGHT BACK COVER ASSY

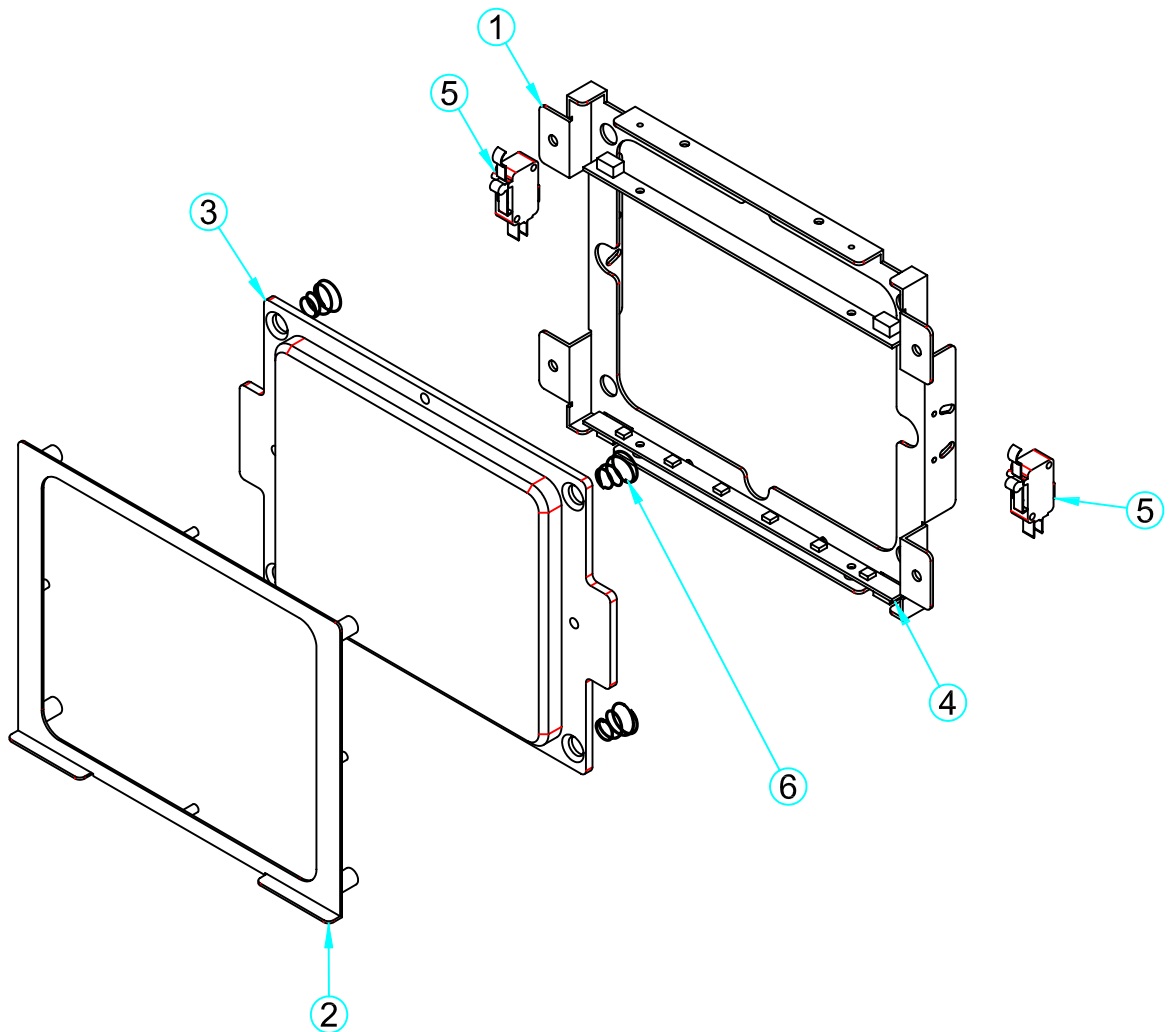

NO.	PART NAME	SPEC.	QUANTITY	CODE NO.
1	BUTTON LIGHT COVER	-	1	MALA0MEP011
2	FRESNEL BUTTON CAP BRKT	-	1	MALA0MEP010
3	FRESNEL BUTTON	-	1	MALA0ACR014
4	BUTTON LED PCB ASS'Y	-	2	AALA0PCB008
5	MICRO SWITCH	GSM-V1643A2	2	MELE0MIC004
6	BUTTON SPRING	-	2-4	MALA0SPR001

8-4.ASSEMBLING FRESNEL BUTTON ASSY

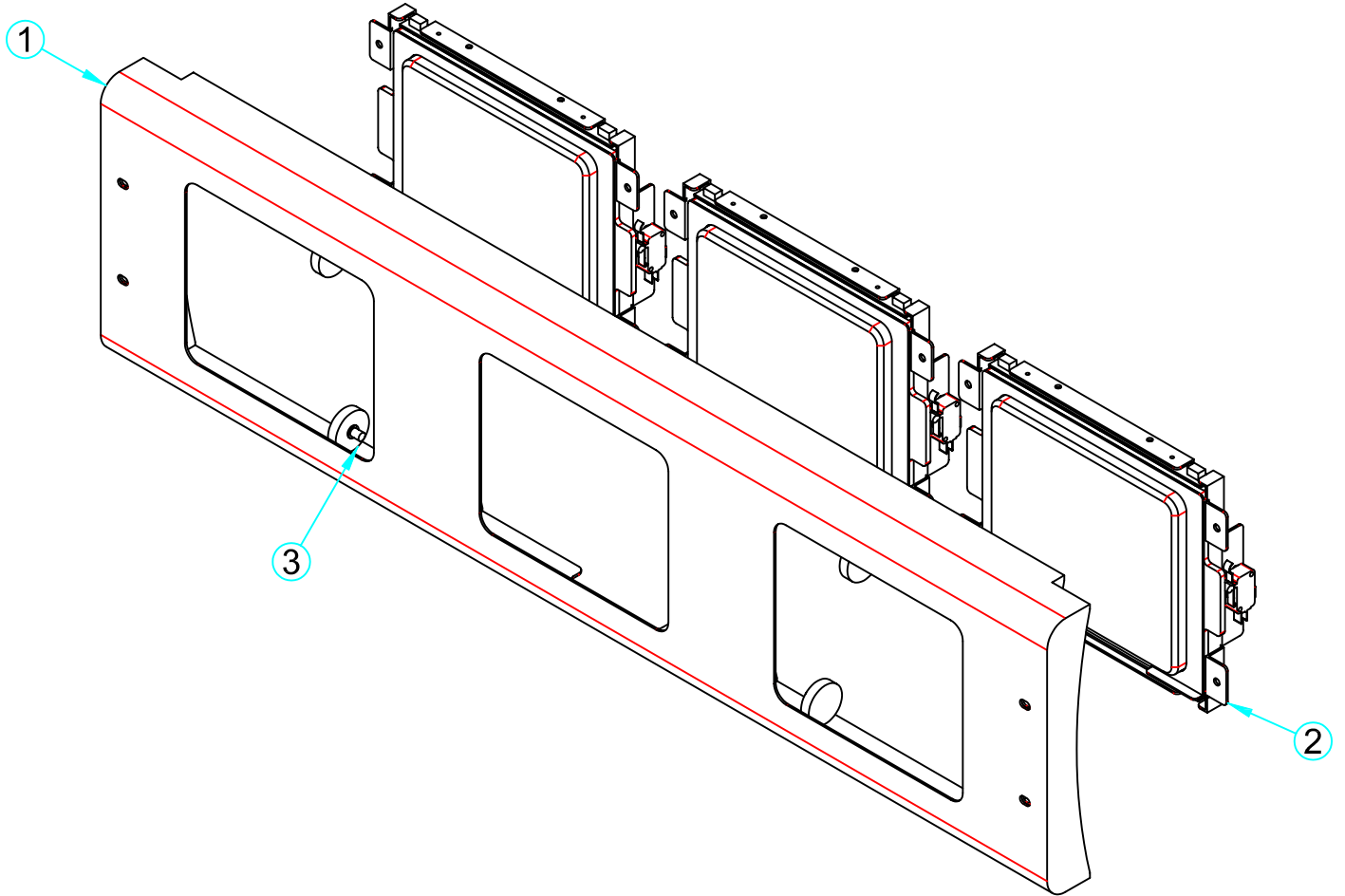

NO.	PART NAME	SPEC.	QUANTITY	CODE NO.
1	FRESNEL BUTTON BOTTOM	-	1	MALA0MEP009
2	BUTTON LIGHT BACK COVER ASSY	-	3	8-3(PAGE 22)
3	BEARING	PAT42167RW-30	4	MALA0BEA001

8-5.ASSEMBLING MIDDLE BILLBOARD BOX ASSY

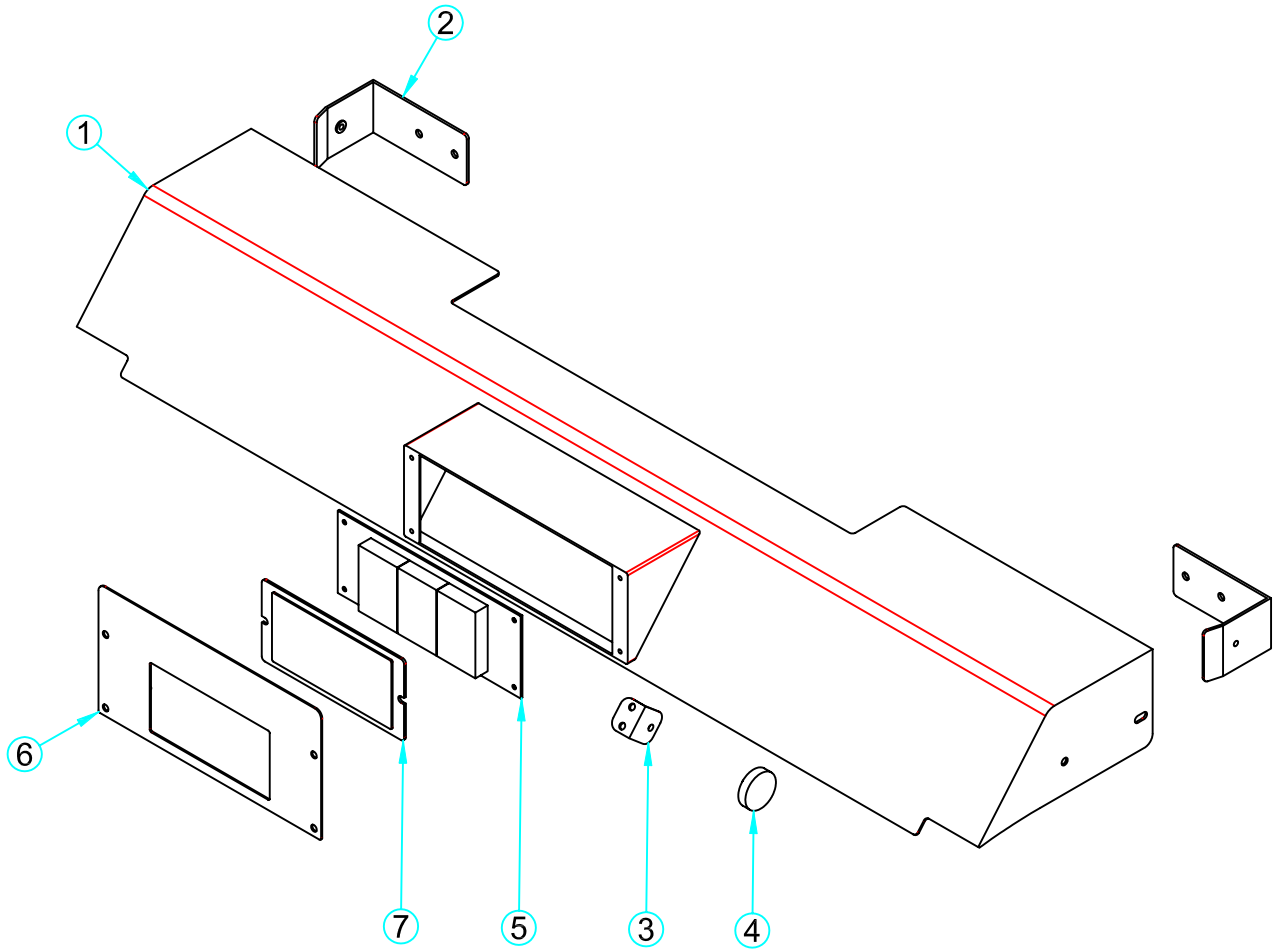

NO.	PART NAME	SPEC.	QUANTITY	CODE NO.
1	MIDDLE BILLBOARD BOX	-	1	MALA0MEP050
2	MIDDLE BILLBOARD SIDE BRKT	-	2	MALA0MEP052
3	MIDDLE BILLBOARD DR30 BRKT	-	2	MALA0MEP051
4	BEARING	PAT42167RW-30	2	MALA0BEA001
5	TICKETS OWED FND PCB ASSY	-	1	AALA0PCB003
6	3 TICKETS OWED FND PLATE	-	1	MALA0MEP044
7	3 TICKETS OWED FND ACRYL	-	1	MALA0ACR017

8-6.ASSEMBLING COIN FND ASSY

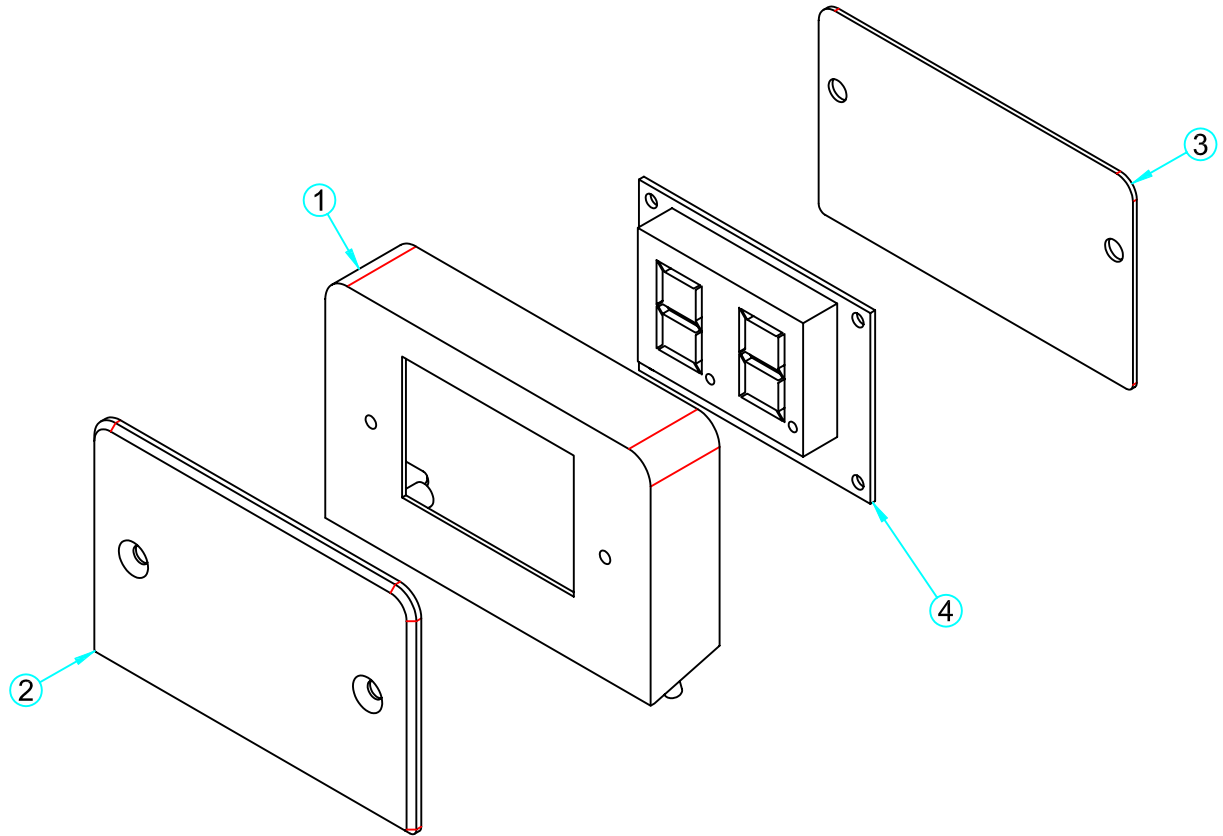

NO.	PART NAME	SPEC.	QUANTITY	CODE NO.
1	COIN FND BRKT A	-	1	MALA0MEP046
2	COIN FND ACRYL	-	1	MALA0ACR015
3	COIN FND BRKT B	-	1	MALA0MEP047
4	CREDIT FND PCB ASS'Y	-	1	AALA0PCB009

8-7.ASSEMBLING POWER SWITCH SETUP ASSY

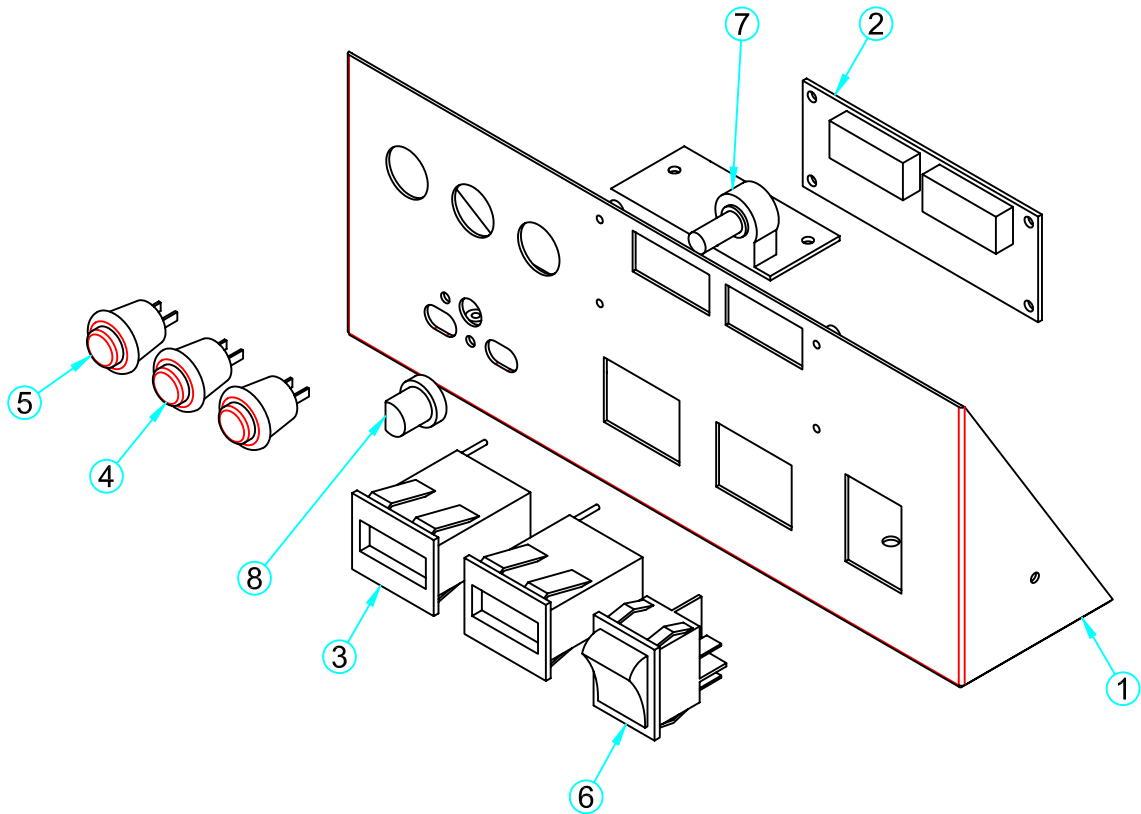

NO.	PART NAME	SPEC.	QUANTITY	CODE NO.
1	AC POWER SWITCH BRACKET	-	1	MALA0MEP004
2	SETUP FND PCB ASSY	-	1	AALA0PCB004
3	COUNTER	AMMC-712(7D12V)	2	MZZZ0COU002
4	PUSH BUTTON SWITCH-W	412W	2	MELE0PUS002
5	PUSH BUTTON SWITCH-R	412R	1	MELE0PUS001
6	ROCKER SWITCH	T-125 4P	1	MELE0SWI004
7	VR PCB ASSY 10K	-	1	AMUH0PCB003
8	VOLUMN KNOB	-	2	MELE0VOL006

8-8.ASSEMBLING FIRE LIGHT ASSY

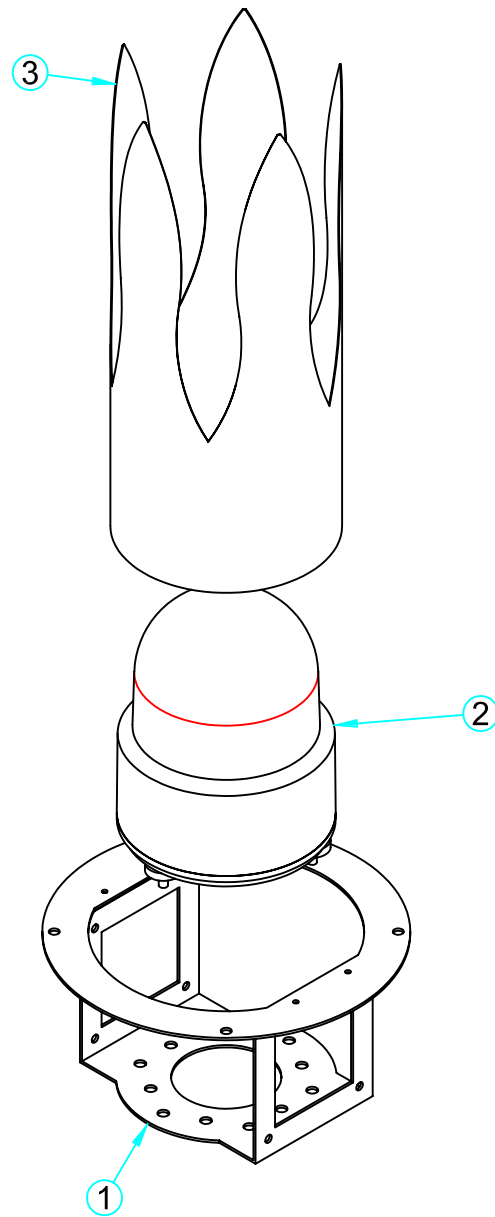

NO.	PART NAME	SPEC.	QUANTITY	CODE NO.
1	FIRE LIGHT TOP COVER	-	1	MALA0MEP039
2	RED FLASHER 125mm RED	Q-LIGHT 125R DC 12V	1	MALA0000001
3	FIRE SHEET	-	1	MALA0SHE015

8-9.ASSEMBLING 3 WAVES LAMP

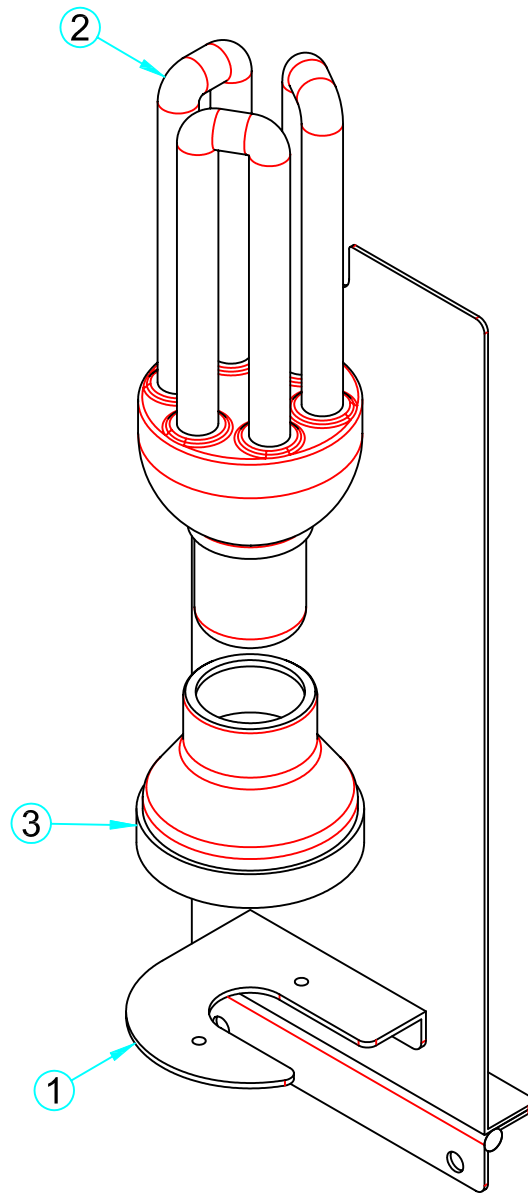

NO.	PART NAME	SPEC.	QUANTITY	CODE NO.
1	MASK LAMP WELD ASSY	-	1	MALA0MEP006
2	LAMP	3 WAVE (110V 20W)	1	MELE0LAM005
3	AC RECEPTACLE	-	1	MELE0ARE002

8-10.ASSEMBLING MAIN PCB PW ASSY

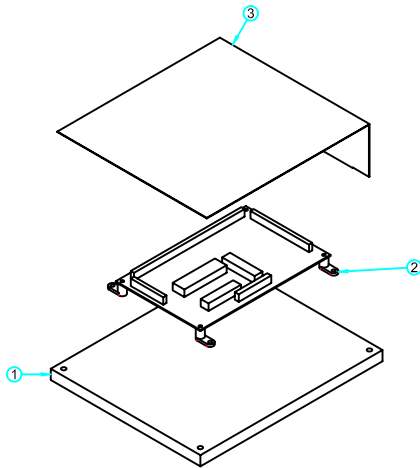

NO.	PART NAME	SPEC.	QUANTITY	CODE NO.
1	MAIN PCB MDF PANEL	-	1	MALA0W00009
2	MAIN PCB ASS'Y	-	1	AALA0PCB001
3	MAIN PCB PET COVER	-	1	MALA0ACR012

8-11.ASSEMBLING COIN BOX ASSY

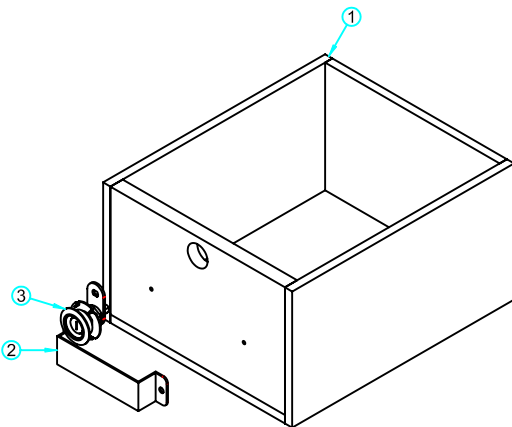

NO.	PART NAME	SPEC.	QUANTITY	CODE NO.
1	COIN BOX	-	1	MALA0W00007
2	COIN BOX HANDLE	-	1	MALA0MEP026
3	KEY ASS'Y	6001	1	MZZZ0KEY013

8-12.ASSEMBLING AC INPUT BRACKET

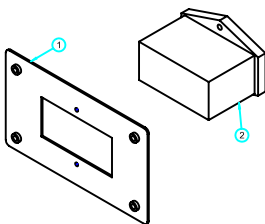

NO.	PART NAME	SPEC.	QUANTITY	CODE NO.
1	AC SOKET BRKT	-	1	MALA0MEP025
2	NOISE FILTER	IP-0642-H2	1	MELE0NOI002

8-13.ASSEMBLING POWER MDF PANNEL

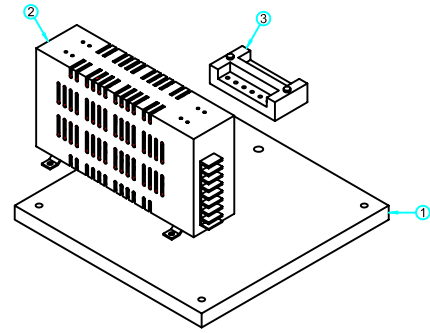

NO.	PART NAME	SPEC.	QUANTITY	CODE NO.
1	POWER MDF PANNEL	-	1	MALA0W00010
2	POWER-SMPS CSR028A	DC5V-8A 12V-7A	1	MELE0SMP018
3	TERMINAL BLOCK	6P UL	1	MELE0TEB001

8-14.ASSEMBLING 4 JACKPOT FND

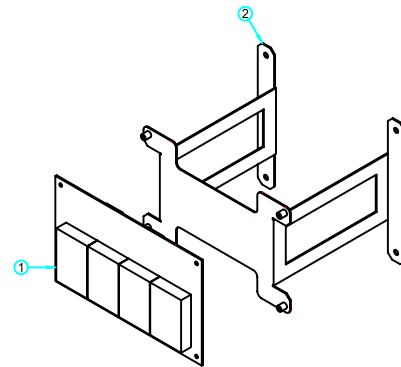

NO.	PART NAME	SPEC.	QUANTITY	CODE NO.
1	JACKPOT FND PCB	-	1	AALA0PCB002
2	4 JACKPOT FND BRKT	-	1	MALA0MEP045

8-15.ASSEMBLING HEAD LIGHT

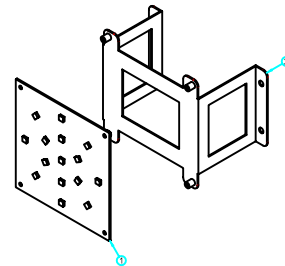

NO.	PART NAME	SPEC.	QUANTITY	CODE NO.
1	MASK HAED PCB ASS'Y	-	1	AALA0PCB006
2	MASK HED LIGHT BRKT	-	1	MALA0MEP038

8-16.ASSEMBLING MASK SIDE LIGHT

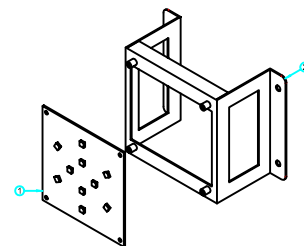

NO.	PART NAME	SPEC.	QUANTITY	CODE NO.
1	MASK SIDE LED PCB ASS'Y	-	1	AALA0PCB005
2	MASK SIDE LIGHT BRKT	-	1	MALA0MEP049

8-18.ASSEMBLING TRAIN MASK VACUUM ELECTRONIC

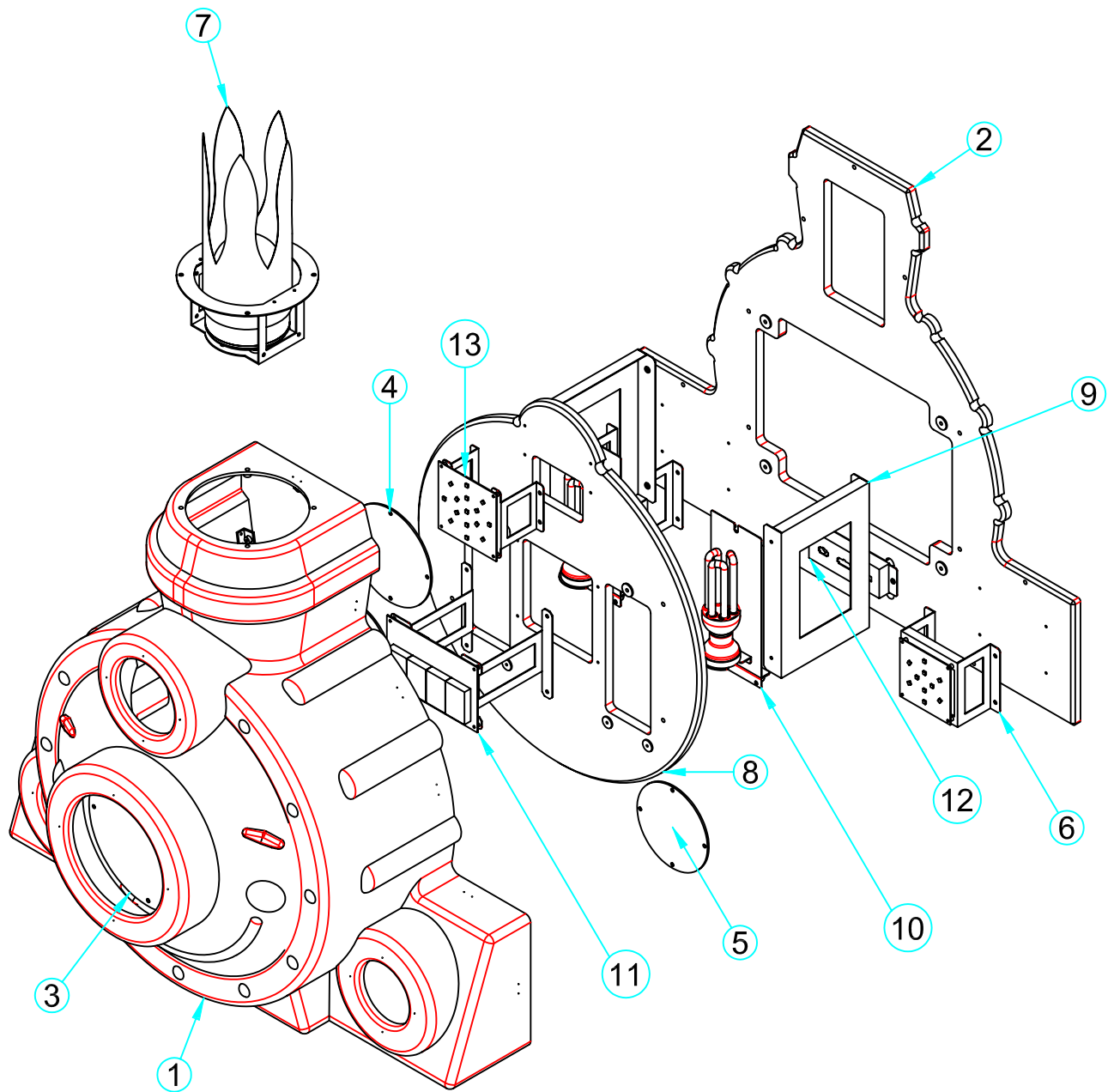

NO.	PART NAME	SPEC.	QUANTITY	CODE NO.
1	TRAIN MASK VACUUM SUPPORT ASSY	-	1	AAEA0VAC001
2	TRAIN MASK MDF COVER	-	1	MALA0WOO005
3	MASK FND PC SHEET 4 JACKPOT FND ACRYL	-	1	MALA0SHE011 MALA0ACR016
4	MASK HEAD LIGHT ACRYL	-	1	MALA0ACR011
5	MASK SIDE LIGHT ACRYL	-	2	MALA0SHE017
6	MASK SIDE LIGHT ASSY	-	2	8-16(PAGE 29)
7	FIRE LIGHT ASSY	-	1	8-8(PAGE 27)
8	TRAIN MASK INNER COVER	-	1	MALA0WOO004
9	INNER COVER BRKT	-	2	MALA0MEP043
10	3 WAVES LAMP ASSY	-	2	8-9(PAGE 28)
11	4 JACKPOT FND ASSY	-	1	8-14(PAGE 29)
12	MASK CONNECTOR BRKT	-	1	MALA0MEP003
13	HEAD LIGHT ASSY	-	1	8-15(PAGE 29)

8-19.ASSEMBLING TRAIN MASK VACUUM REAR BOX

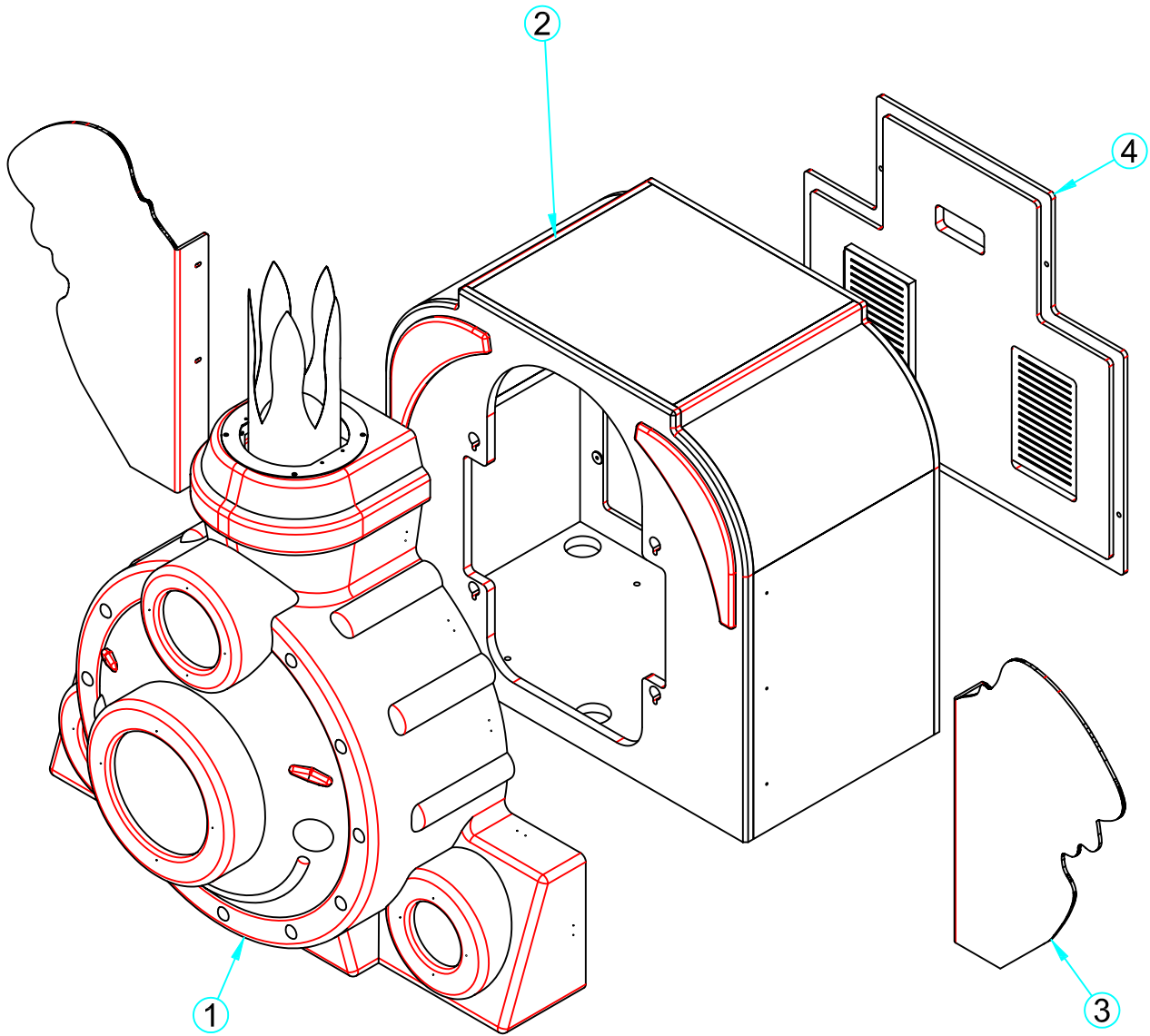

NO.	PART NAME	SPEC.	QUANTITY	CODE NO.
1	TRAIN MASK VACUUM ELECTRONIC ASSY	-	1	8-18(PAGE 30)
2	TRAIN REAR BOX SUPPORT ASSY	-	1	MALA0WOO003
3	TRAIN POP L,R	-	2	MALA0SHE012 MALA0ACR003
4	REAR BOX BACK DOOR	-	1	-

8-20.ASSEMBLING MOTOR PULLEY

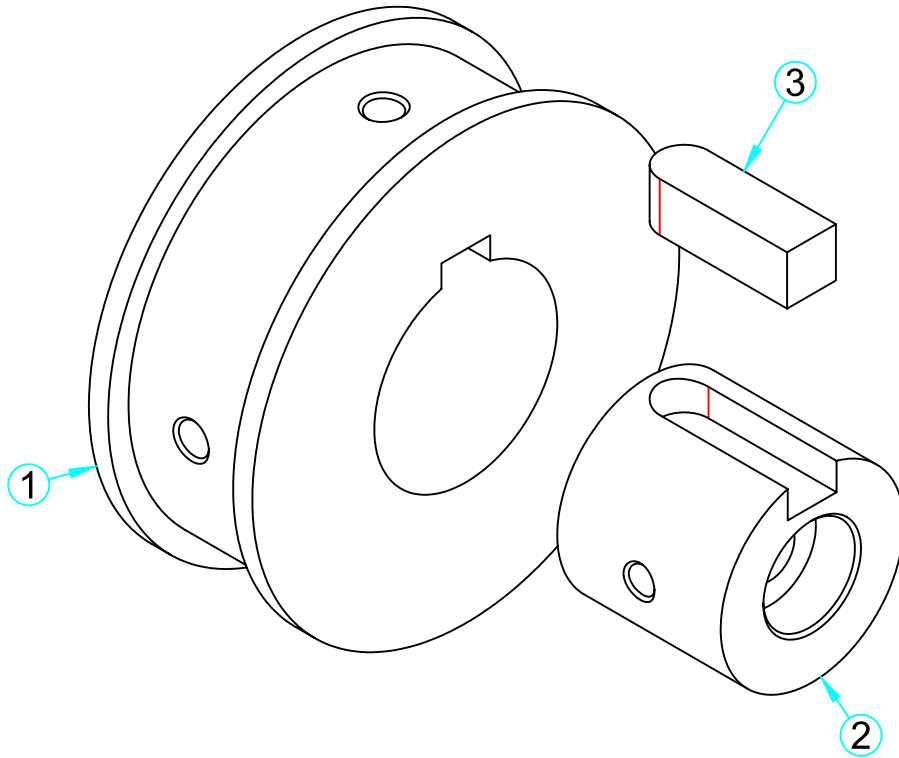

NO.	PART NAME	SPEC.	QUANTITY	CODE NO.
1	16H075 - 33F PULLEY	-	1	MALA0PRO006
2	16H075 - 33F PULLEY HOUSING	-	1	MALA0PRO007
3	PULLEY SHAFT KEY	-	1	MALA0PRO008

8-21.ASSEMBLING WHEEL MAIN SHAFT

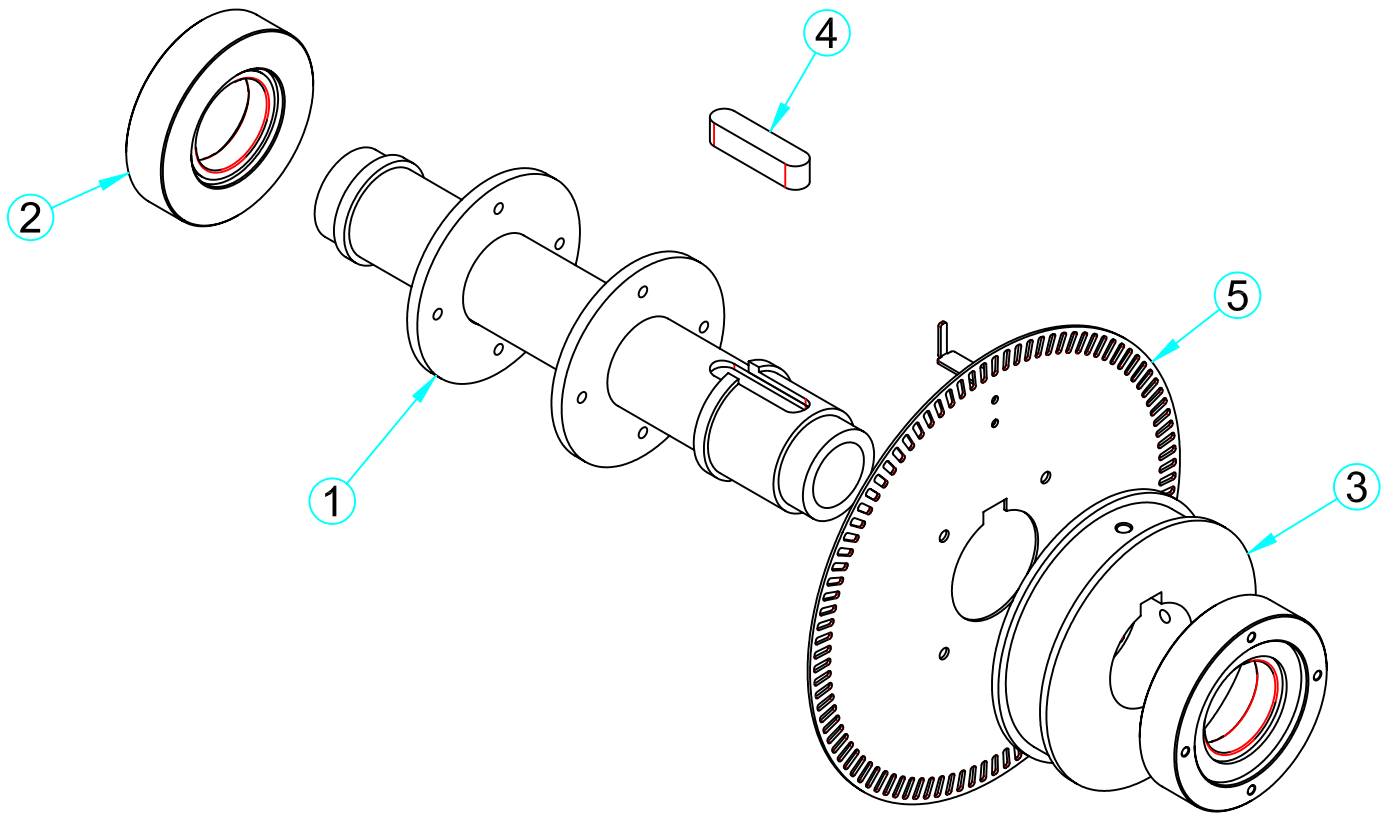

NO.	PART NAME	SPEC.	QUANTITY	CODE NO.
1	WHEEL MAIN SHAFT WELDING ASSY	-	1	MALA0PRO001
2	WHEEL BEARING BLOCK ASSY	-	1	MALA0PRO005
3	24H075 - 33F PULLEY	-	1	MALA0PRO002
4	WHEEL SHAFT KEY	-	1	MALA0PRO003
5	ENCODER SENSOR BRACKET ASSY	-	1	MALA0MEP008

8-22.ASSEMBLING MAIN WHEEL

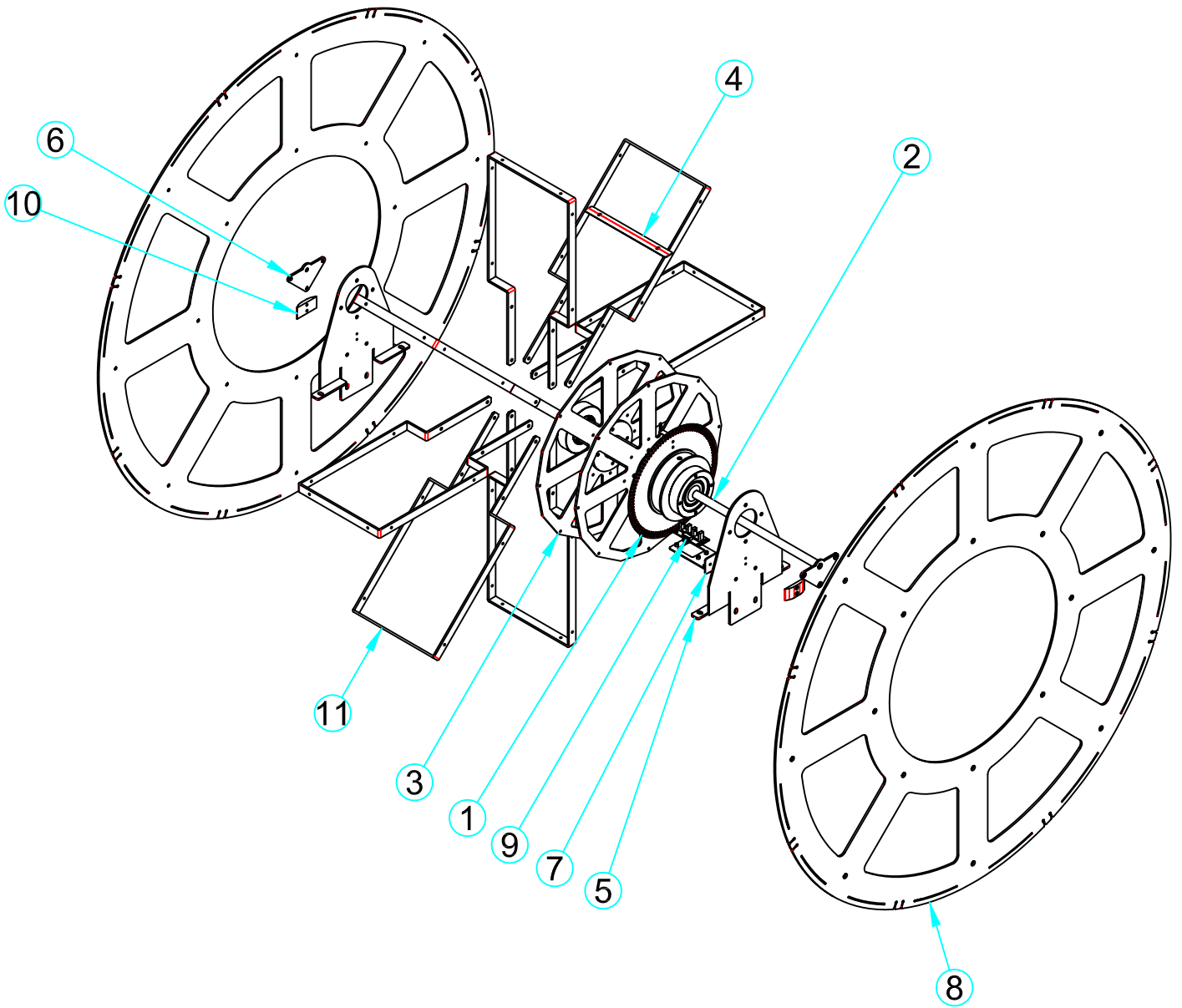

NO.	PART NAME	SPEC.	QUANTITY	CODE NO.
1	WHEEL MAIN SHAFT ASSY	-	1	8-21(PAGE 33)
2	WHEEL SUB SHAFT	-	1	MALA0PRO004
3	WHEEL SIDE SUPPORT A	-	2	MALA0MEP020
4	PATTERN B PLUSE BRKT	-	8	MALA0MEP054
5	WHEEL HOUSING BRKT A	-	2	MALA0MEP016
6	WHEEL SUB BRKT A	-	2	MALA0MEP022
7	SENSOR PCB BRKT	-	1	MALA0MEP012
8	WHEEL FOMEX SIDE SHEET	-	2	MALA0ACR002
9	PHOTO SENSOR PCB ASS'Y	-	1	AALA0PCB010
10	SIDE GAP SLIDE MC NYLON	-	2	MALA0PRO009
11	WHEEL LIB PATTERN C	-	8	MALA0MEP017

8-23.ASSEMBLING WHEEL BASE

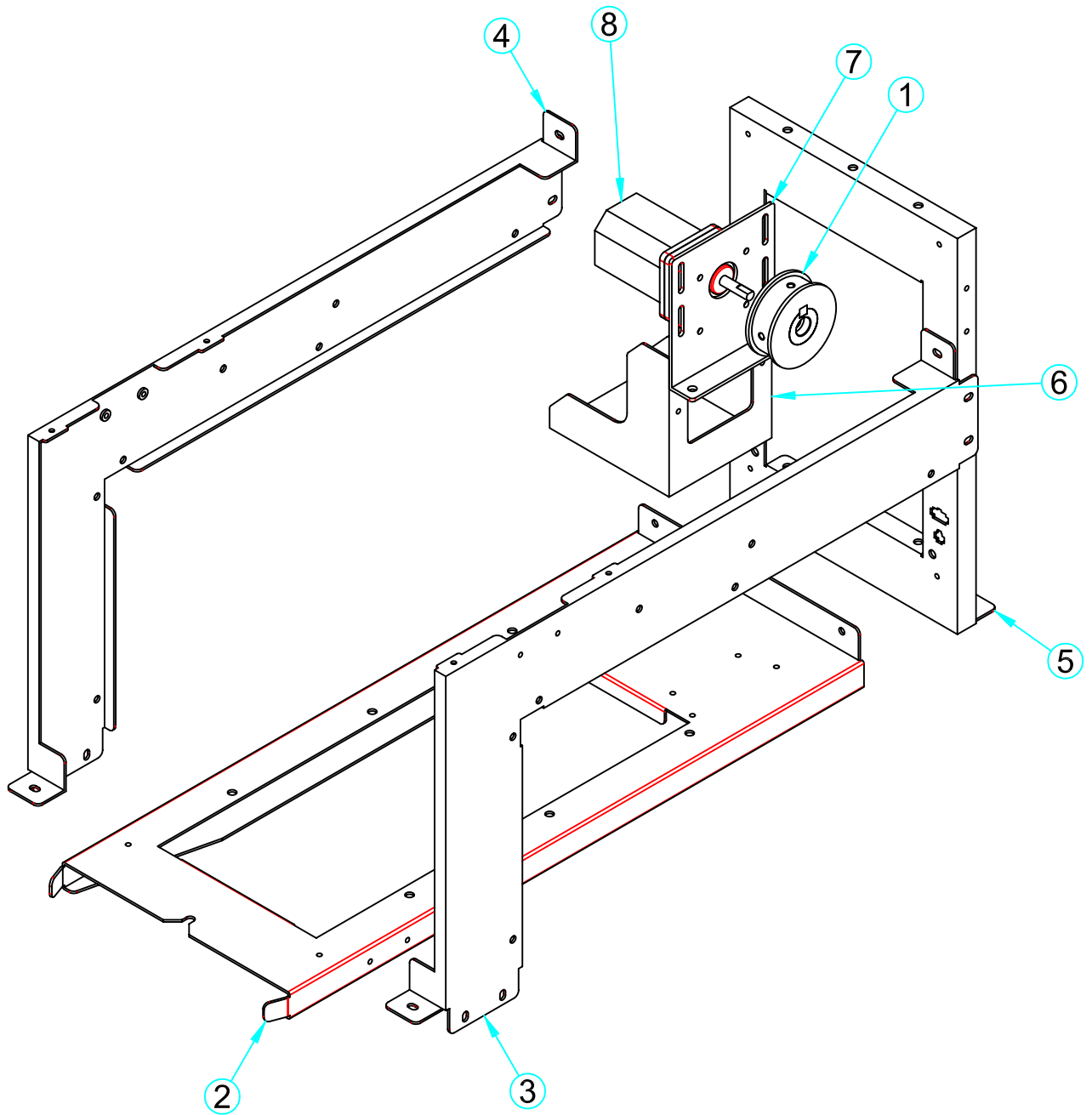

NO.	PART NAME	SPEC.	QUANTITY	CODE NO.
1	MOTOR PULLEY ASSY	-	1	8-20(PAGE 32)
2	WHEEL BOTTOM PANEL	-	1	MALA0MEP015
3	WHEEL SIDE PANEL L	-	1	MALA0MEP019
4	WHEEL SIDE PANEL R	-	1	MALA0MEP019
5	WHEEL REAR PANEL	-	1	MALA0MEP018
6	MOTOR SUPPORT BRKT	-	1	MALA0MEP027
7	PULLEY MOTOR BRACKET	-	1	MALA0MEP028
8	MOTOR MOTOR(GEAR HEAD)	MOTOR -K6DG6N1 (DC12V-6W) GEAR HEAD-K6G75C (K6G-1:075)	1	MALA0MOT001 MALA0MOT002

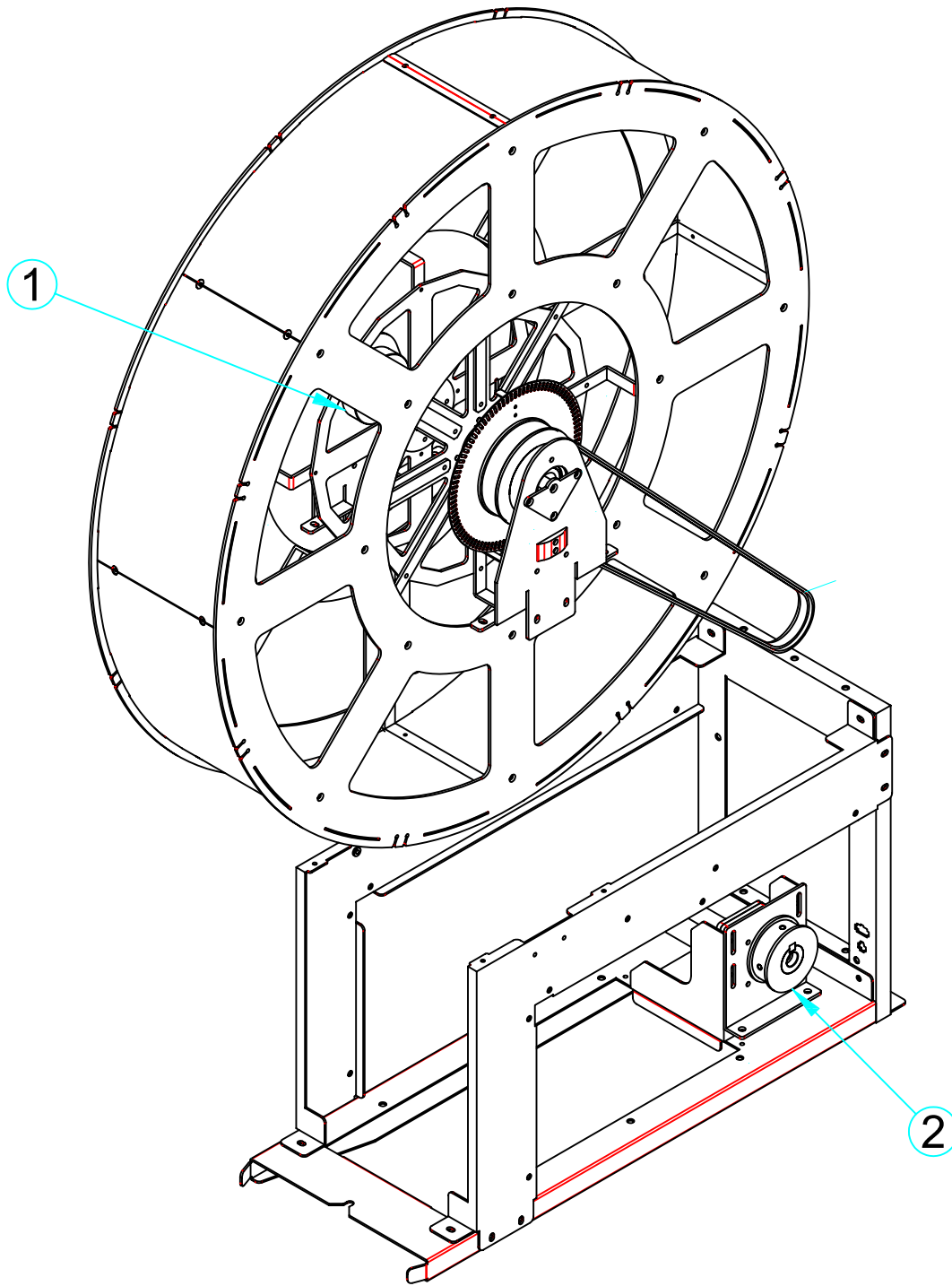

NO.	PART NAME	SPEC.	QUANTITY	CODE NO.
1	MAIN WHEEL ASSY	-	1	8-22(PAGE 34)
2	WHEEL BASE ASSY	-	1	8-23(PAGE 35)

8-25.ASSEMBLING THIRD ABOARD

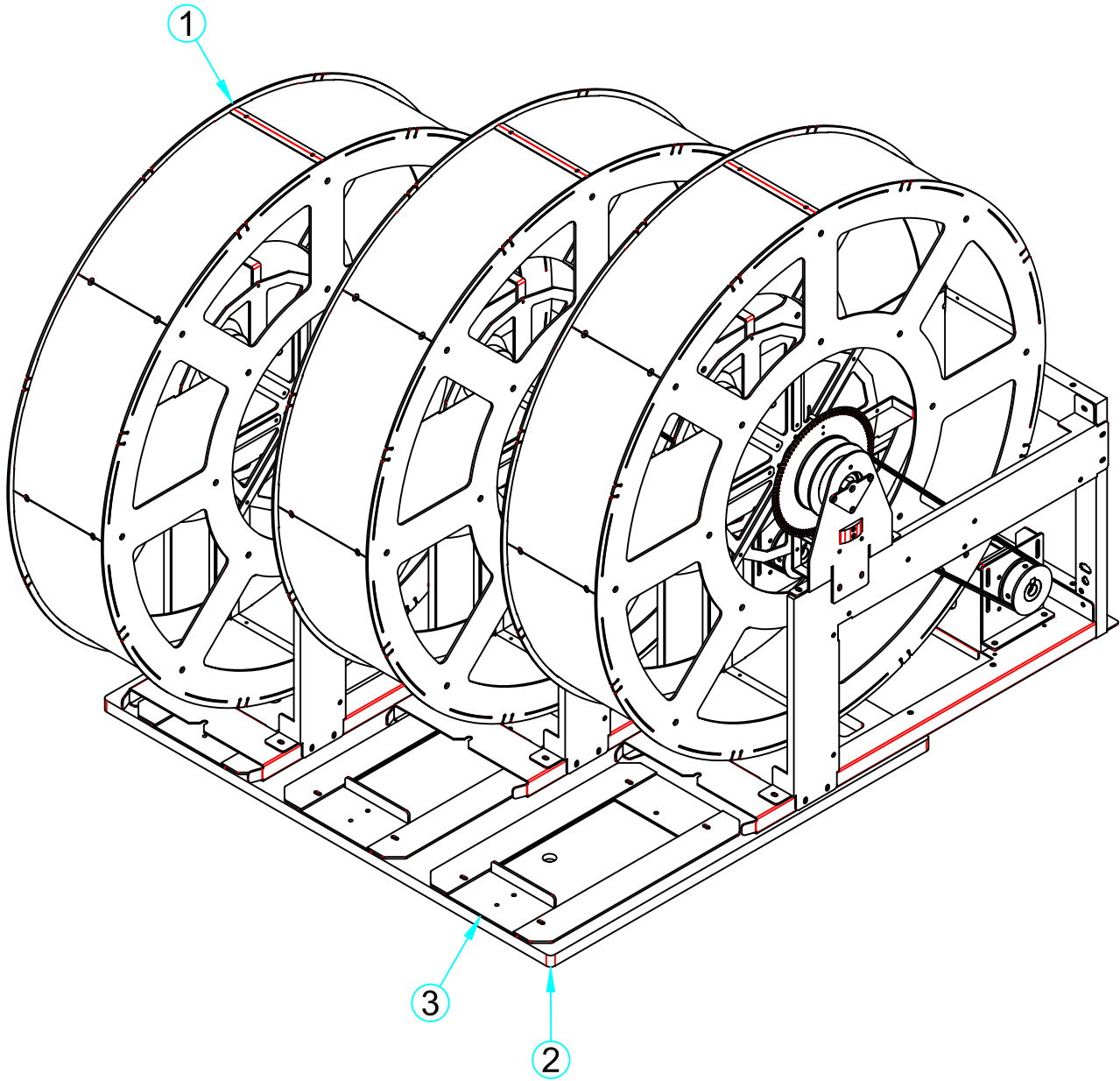

NO.	PART NAME	SPEC.	QUANTITY	CODE NO.
1	WHEEL BASE ASSY 173	-	3	8-24(PAGE 36)
2	WHELL BASE PANEL	-	1	MALA0WOO006
3	WHEEL SLIDE GUIDE BRKT	-	1	MALA0MEP021

8-26.ASSEMBLING SIDE LIGHT ACRYL

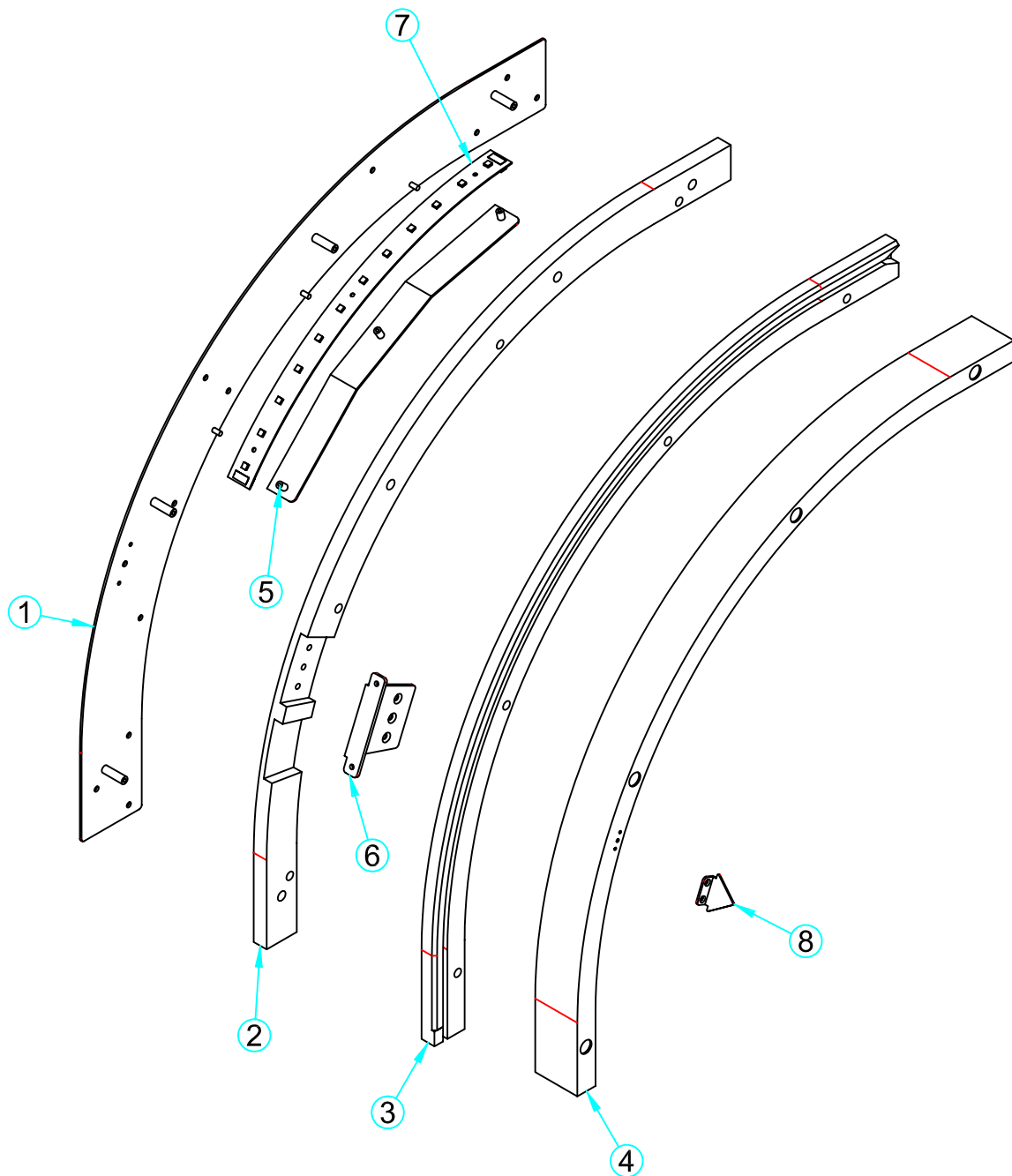

NO.	PART NAME	SPEC.	QUANTITY	CODE NO.
1	SIDE LIGHT ACRYL BRKT A	-	1	MALA0MEP030
2	SIDE LIGHT ACRYL A	-	1	MALA0ACR006
3	SIDE LIGHT ACRYL B	-	1	MALA0ACR005
4	SIDE LIGHT ACRYL BRKT d	-	1	MALA0MEP032
5	SIDE LIGHT ACRYL BRKT b	-	1	MALA0MEP031
6	FRESNEL BUTTON SIDE BRKT	-	1	MALA0MEP040
7	WHEEL SIDE LED BULE PCB ASSY	-	1	AALA0PCB007
8	ARROW PLATE A	-	1	MALA0MEP002

8-27.ASSEMBLING MIDDLE LIGHT ACRYL

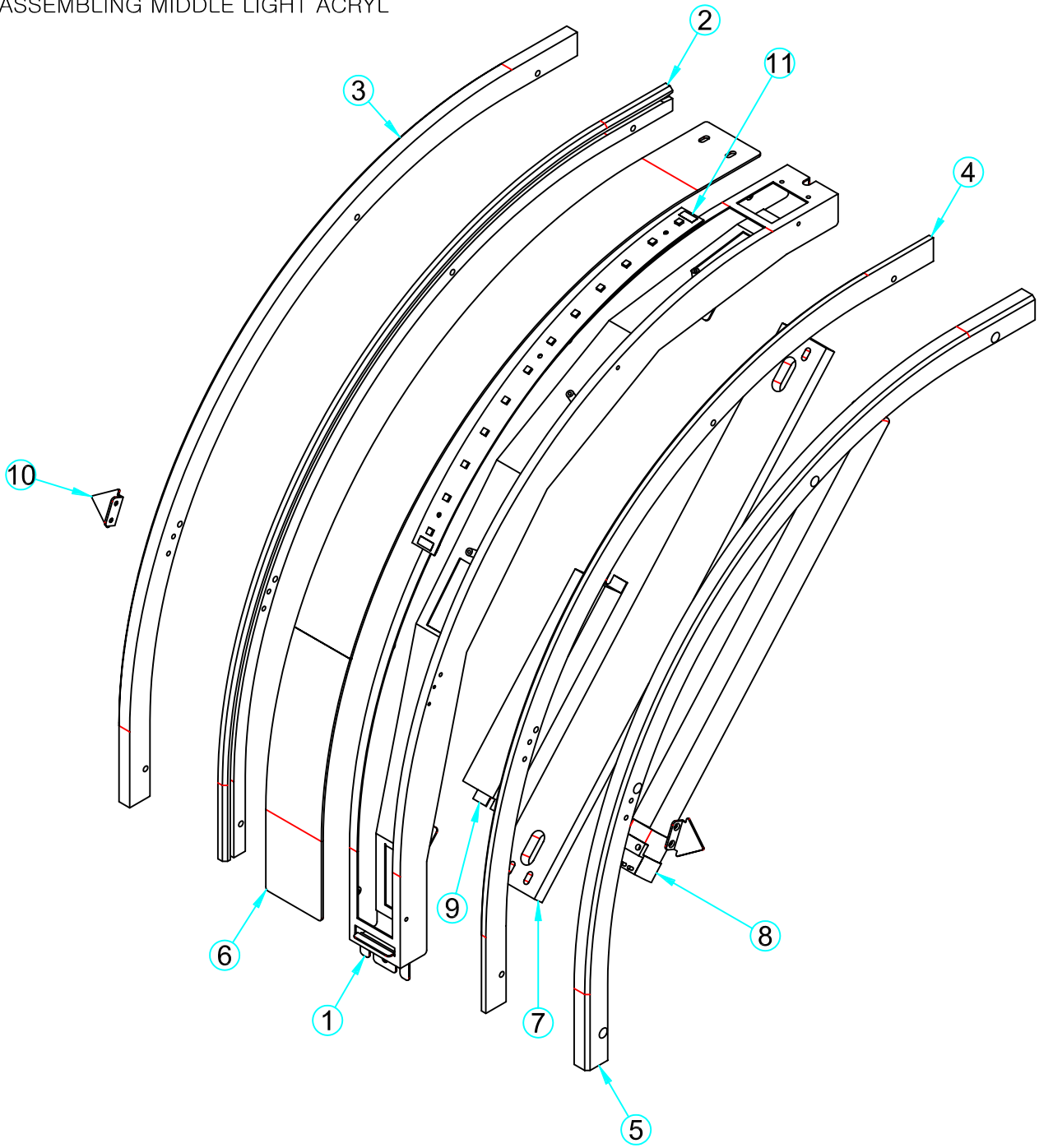

NO.	PART NAME	SPEC.	QUANTITY	CODE NO.
1	MIDDLE LIGHT ACRYL BRKT B	-	1	MALA0MEP053
2	MIDDLE LIGHT ACRYL A	-	1	MALA0ACR010
3	MIDDLE LIGHT ACRYL B	-	1	MALA0ACR009
4	MIDDLE LIGHT ACRYL A(대칭품)	-	1	MALA0ACR010
5	MIDDLE LIGHT ACRYL B(대칭품)	-	1	MALA0ACR009
6	MIDDLE LIGHT PC	-	1	MALA0ACR008
7	MIDDLE PL LIGHT PW	-	1	MALA0WOO011
8	LAMP(PL)	110V36W P/L LAMP	1	MMST0ELE006
9	ELECTRONIC BALLAST	-	1	MALA0000002
10	ARROW PLATE A	-	2	MALA0MEP002
11	WHEEL SIDE LED RGB PCB ASSY	-	1	ALA0PCB011

8-28.ASSEMBLING SIDE MIDDLE ACRYL LIGHT

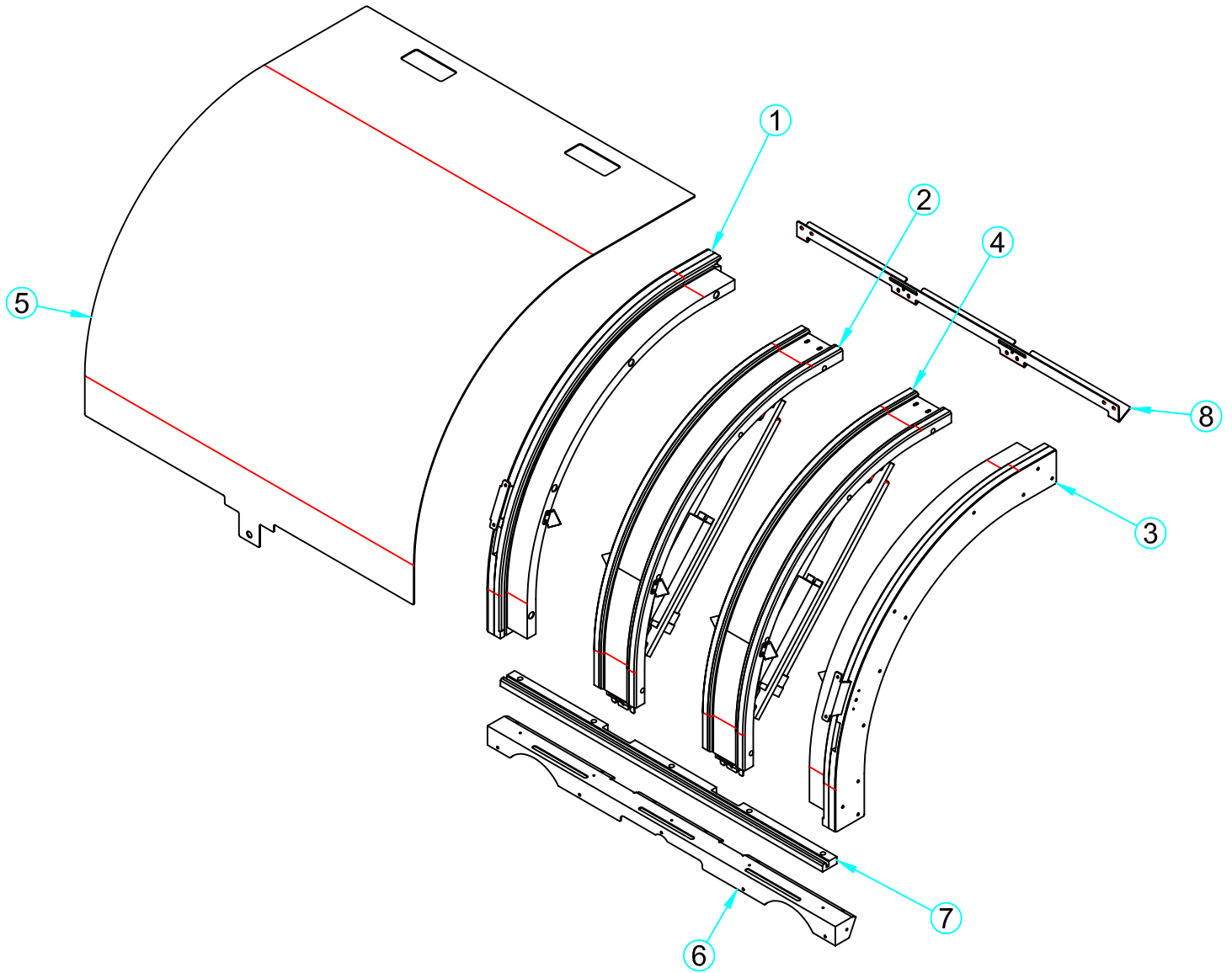

NO.	PART NAME	SPEC.	QUANTITY	CODE NO.
1	SIDE LIGHT ACRYL ASSY	-	1	8-26(PAGE 38)
2	MIDDLE LIGHT ACRYL ASSY	-	1	8-27(PAGE 39)
3	SIDE LIGHT ACRYL ASSY(symmetry)	-	1	8-26(PAGE 38)
4	MIDDLE LIGHT ACRYL ASSY	-	1	8-27(PAGE 39)
5	FRONT WINDOW POLYCARBONATE	-	1	MALA0ACR013
6	SLIDE LOW BRKT A	-	1	MALA0MEP033
7	SLIDE LOW ACRYL	-	1	MALA0ACR004
8	SLIDE UPPER BRKT A	-	1	MALA0MEP034

8-29.ASSEMBLING MAIN CABINET

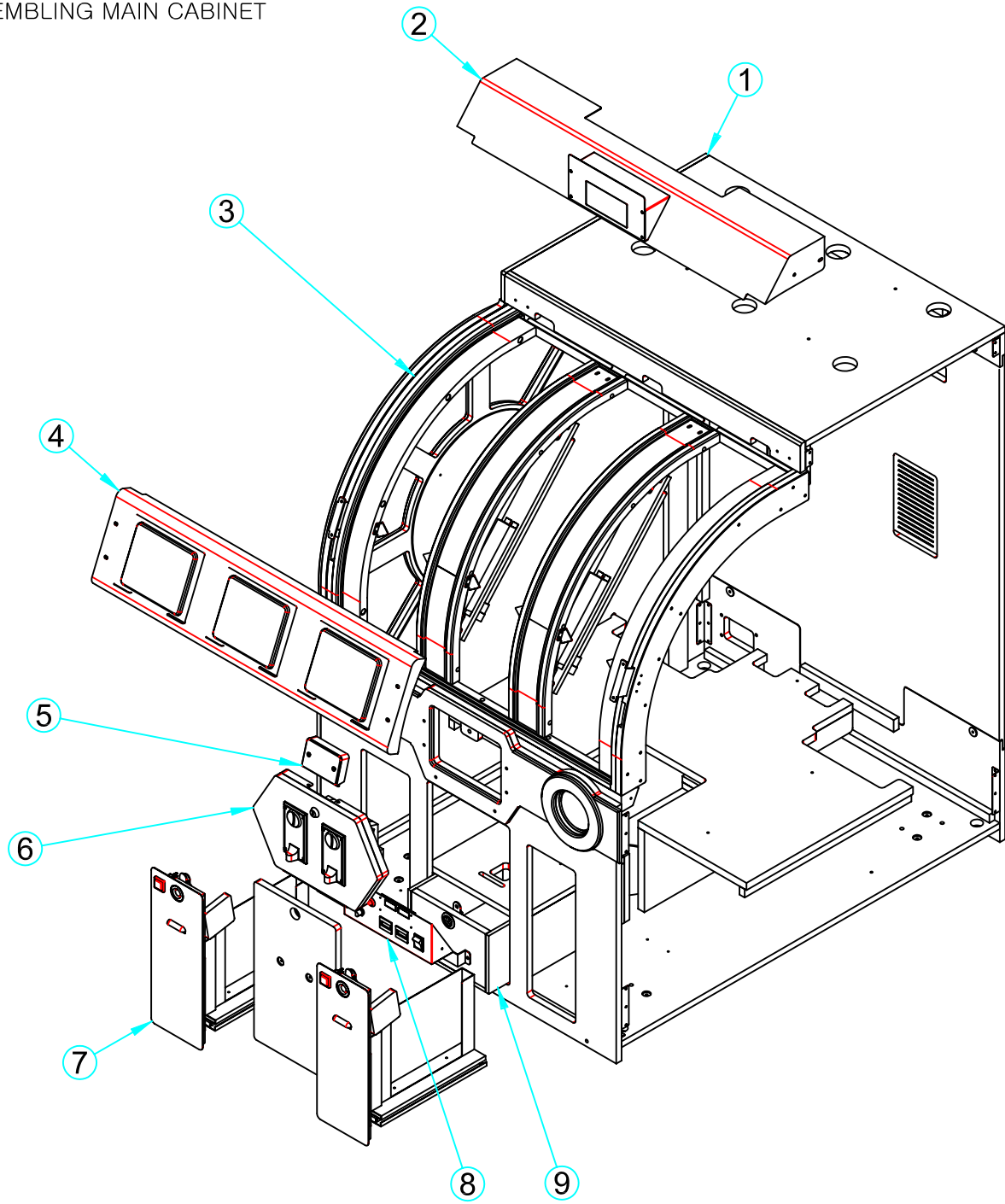

NO.	PART NAME	SPEC.	QUANTITY	CODE NO.
1	ALL ABOARD MDF CABINET ASSY	-	1	MALA0WOO002
2	MIDDLE BILLBOARD BOX ASSY	-	1	8-5(PAGE 24)
3	SIDE MIDDLE ACRYL LIGHT ASSY	-	1	8-28(PAGE 40)
4	FRESNEL BUTTON ASSY	-	1	8-4(PAGE 23)
5	COIN FND ASSY	-	1	8-6(PAGE 25)
6	COIN SEL MAIN ASSY	-	1	8-1(PAGE 20)
7	TICKET DISPENSOR ASSY	-	1	8-2(PAGE 21)
8	POWER SWITCH SETUP ASSY	-	1	8-7(PAGE 26)
9	SLIDE UPPER BRKT A	-	1	8-11(PAGE 29)

8-30.ASSEMBLING MAIN CABINET ELEC

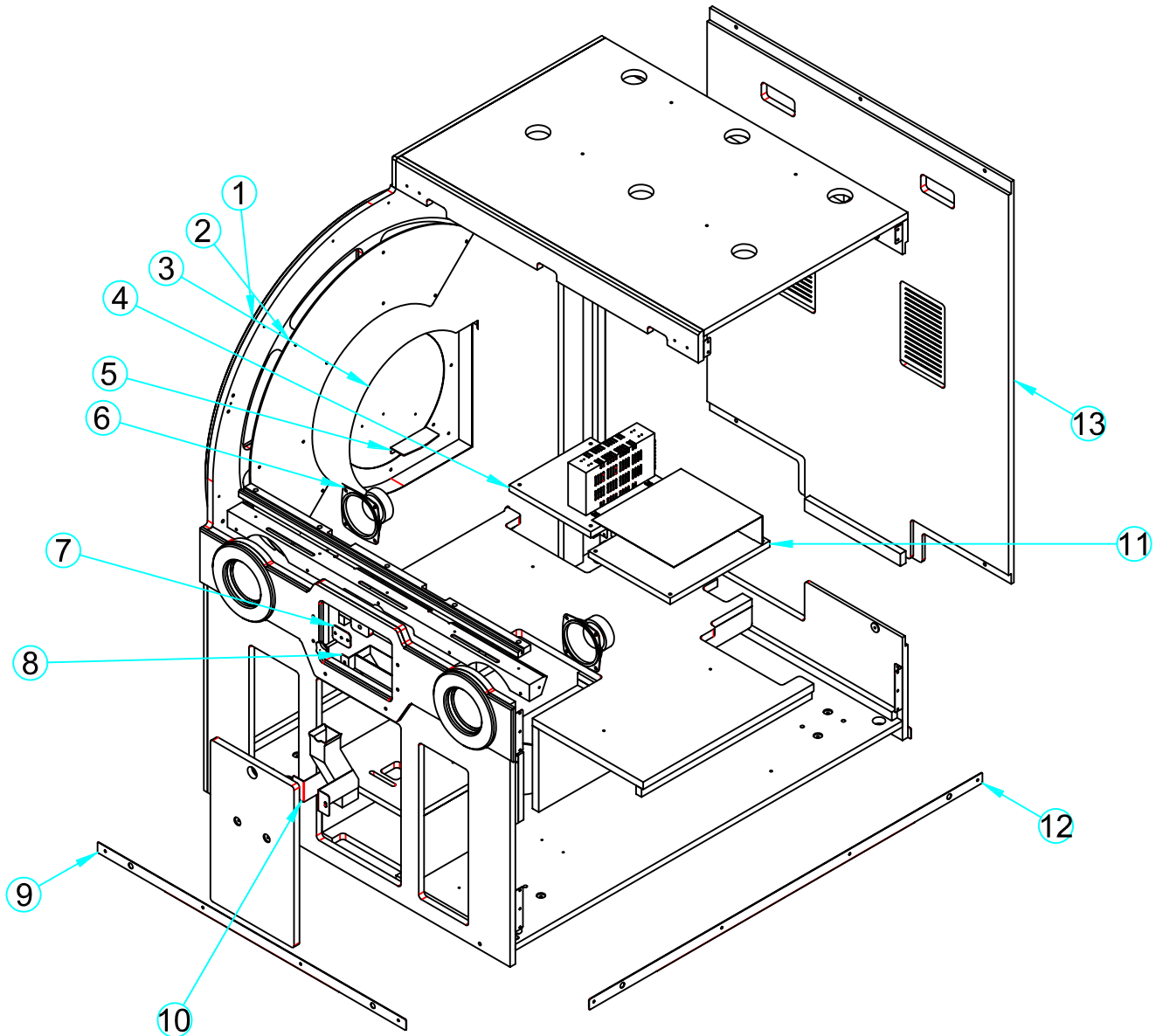

NO.	PART NAME	SPEC.	QUANTITY	CODE NO.
1	ALL ABOARD MDF CABINET ASSY	-	1	MALA0WOO002
2	SIDE INNER ACRYL	-	2	MALA0ACR007
3	WHEEL SIDE BLIND PATCH L WHEEL SIDE BLIND PATCH R	-	1 1	MALA0MEP036 MALA0MEP037
4	POWER MDF PANNEL ASSY	-	1	8-13(PAGE 29)
5	SIDE GAP BRKT L SIDE GAP BRKT R	-	1 1	MALA0MEP014 MALA0MEP013
6	SPEKER	MID 4.5 8Ω 80W	2	MZZZ0SPE004
7	HANDLE BOLT PLATE	-	1	MALA0MEP042
8	Front Coin Rail upper	-	1	MALA0MEP024
9	Front Coin Rail lower	-	1	MALA0MEP023
10	FRONT REAR BENDING	-	2	MALA0MEP041
11	MAIN PCB PW ASSY	-	1	8-10(PAGE 29)
12	SIDE BENDING	-	2	MALA0MEP029
13	BACK DOOR	-	1	-

8-31.ASSEMBLING ALL ABOARD

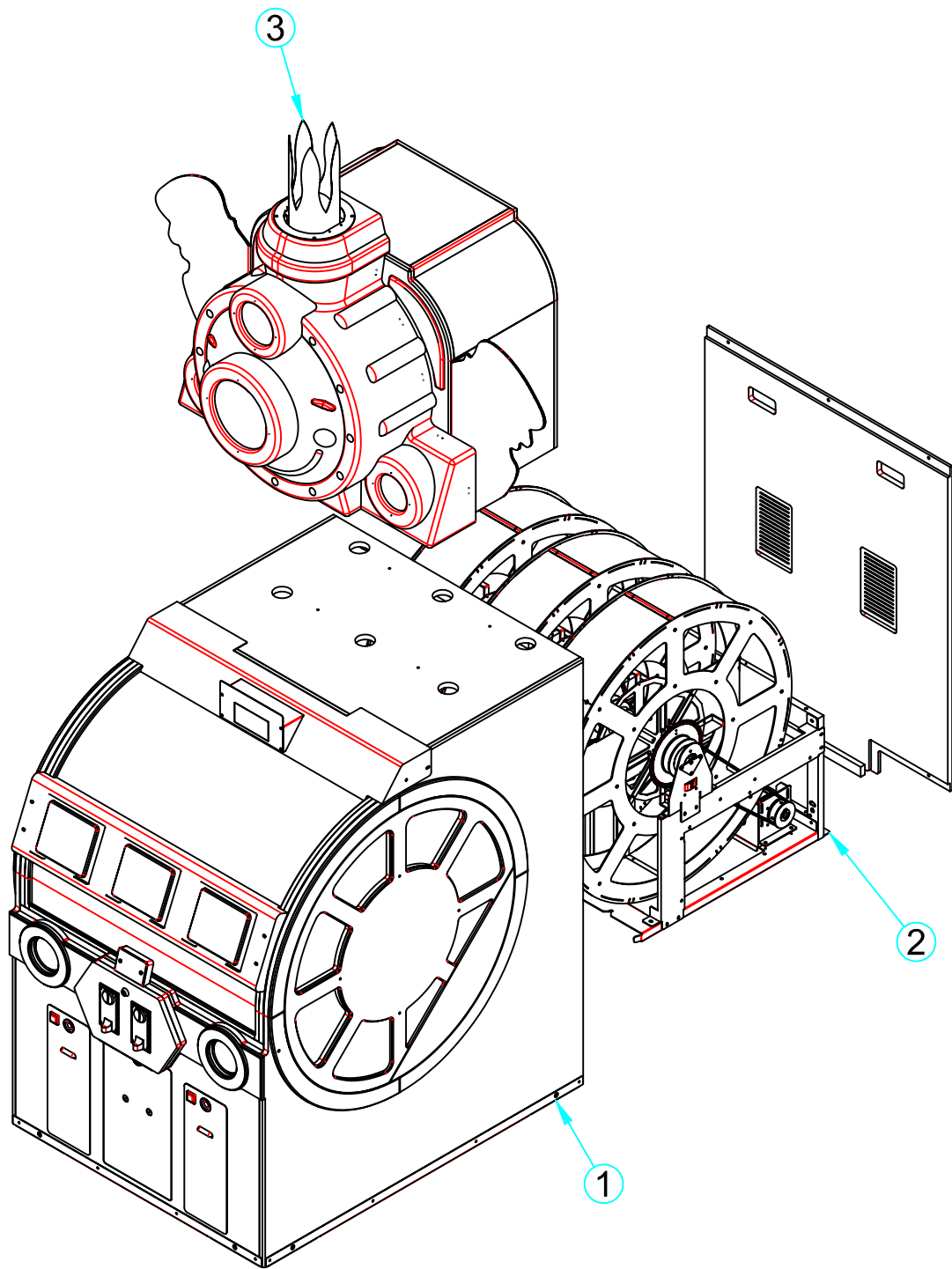

NO.	PART NAME	SPEC.	QUANTITY	CODE NO.
1	ALL ABOARD CABINET ASSY	-	1	-
2	THIRD ABOARD	-	-	-
3	TRAIN MASK VACUUM ASSY	-	1	-

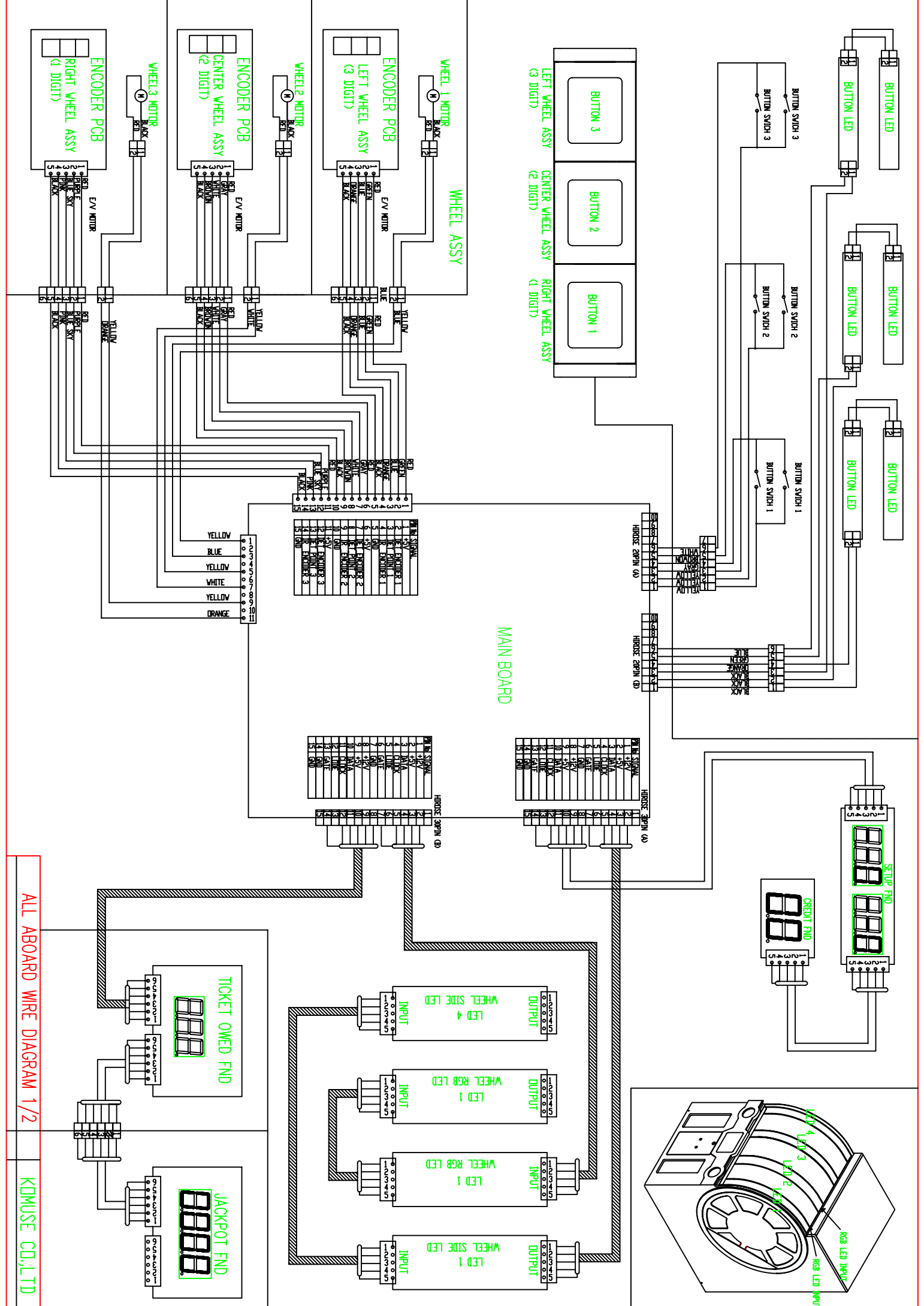





















ALL ABOARD WIRE DIAGRAM 1/2

KAMUSE CO., LTD

ALL ABOARD SHEET

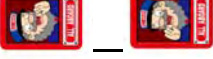

all aboard sheet

	Image	Standard	quantity	material	CDDE NO.
1		SIDE 1104X401	1SET = L/R	Silk screen	MALAOSHE001
2		SIDE LOGO 357 φ	2EA	Silk screen	MALAOSHE002
3		WHEEL SIDE 390X780	4EA	PC Silk screen	MALAOSHE003
4		COIN FND 95X60	1EA	Silk screen	MALAOSHE004
5		DOOR LOGO 231.5	1EA	Silk screen	MALAOSHE005
6		HOW TO PLAY A 48.7X125.7 B, C 80X108 D, E, F 39X17.6	1SET = A/B/C/D/E/F	Silk screen (embo coating)	MALAOSHE006
7		IN COIN 346X214	1EA	Silk screen	MALAOSHE007
8		MIDDLE 318X98	1SET = L/R	Silk screen	MALAOSHE008
9		TICKET OUT 123X287	2EA	Silk screen	MALAOSHE009
10		OWED FND 217X107.5	1EA	Silk screen	MALAOSHE010
11		MASK FND 235 φ	1EA	PC 1T Silk screen	MALAOSHE011
12		POP 320X529	1SET = L/R	Silk screen	MALAOSHE012
13		MARK 98X42	1SET = L/R	Printing	MALAOSHE013
14		MIDDLE LIGHT 63X817	2EA	Light printing	MALAOSHE014
15		FIRE 392.5x300	1EA	Light printing	MALAOSHE015
16		WHEEL 174X310.5	1SET (=24EA)	Light printing	MALAOSHE016
17		MASK SIDE LIGHT ACRYL	2EA	Acryl Miracle Printing	MALAOSHE017
18		TOKEN 42X30	1SET = 1~5	Printing	MALAOSHE018
19		WHEEL NUMBER 6X10	3SET (1SET=1~16)	Print coating	MALAOSHE019
20		POINT 20.5X28	6EA	Reflection Sticker	MALAOSHE020
21		658x409.8	1SET = L/R	Silk screen	MALAOSHE021



A4(210*297)



www.andamirousa.com